

1ST PRINTING APRIL '02

# SEGA



Mini Standard Version

## Owner's Manual



SEGA ENTERPRISES, INC. USA

MANUAL NO. 999-1429

# VISIT OUR WEBSITE!

SegaService.com

Address: <http://www.seuservice.com/>

Apple Central.Sega.com Sega.com SegaService.com Yahoo! Yahoo! Maps and Driving Directions

**SEGA SERVICE**

what's new •  
manuals •  
bulletins •  
assemblies •  
Search •

bulletin Sign-up •  
register name •

staff •  
Darl's Office •  
tech. service •  
warranty policy •

corporate info •  
home page •  
future technologies •  
plugins •  
non-framed page •

Sega Enterprises Inc.,  
USA  
Service Department  
phone 415.701.6580  
fax 415.701.6594

  
**Ask Dave!**

**SEGA SERVICE**

- Bulletins
- Darl's Office
- Game Manuals
- Search
- What's New



**5564** people have visited this page since 3/16/01

If you have any questions or comments  
about this site please E-Mail to [Darl.Davidson@seu.sega.com](mailto:Darl.Davidson@seu.sega.com)

THIS WEB SITE POWERED BY  
**WebSTAR 4.3** Mac OS

[\[what's new\]](#)[\[manuals\]](#)[\[bulletins\]](#)[\[assemblies\]](#)[\[Search\]](#)[\[staff\]](#)[\[Darl's office\]](#)  
[\[technical service\]](#)[\[customer service\]](#)[\[corporate info\]](#)[\[plugins\]](#)[\[Non-framed page\]](#)

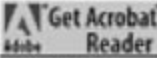
You will need the following items to view this page in its entirety.

 **Get Acrobat Reader**  **GET Microsoft Internet Explorer**  **GET Microsoft Internet Explorer**

All Platforms Windows Macintosh

Internet zone

## BEFORE USING THE PRODUCT, BE SURE TO READ THE FOLLOWING:

To maintain the safety:

To ensure the safe usage of the product, be sure to read the following before using the product. The following instructions are intended for the users, operators and the personnel in charge of the operation of the product. After carefully reading and sufficiently understanding the warning displays and cautions, handle the product appropriately. Be sure to keep this manual nearby the product or elsewhere convenient for referring to it when necessary.

Herein, explanations which require special attention are enclosed with dual lines. Depending on the potentially hazardous degrees, the terms of WARNING, CAUTION, etc. are used. Be sure to understand the contents of the displays before reading the text.



Indicates that mishandling the product by disregarding this warning will cause a potentially hazardous situation which can result in death or serious injury.



Indicates that mishandling the product by disregarding this caution will cause a slight hazardous situation which can result in personal injury and or material damage.

### For the safe usage of the product, the following pictographs are used:



Indicates “HANDLE WITH CARE.” In order to protect the human body an equipment, this display is attached to places where the Owner’s Manual and or Service Manual should be referred to.

- **Perform work in accordance with the instructions herein stated.**  
Instructions for work are explained by paying attention to the aspect of accident prevention. Failing to perform work as per the instructions can cause accidents. In the case where only those who have technical expertise should perform the work to avoid hazardous situation, the instructions herein state that the serviceman should perform such work.
- **Be sure to turn off power before working on the machine.**  
To prevent electric shock, be sure to turn off power before starting the work in which the worker touches the interior of the product. If the work is to be performed in the power-on status, the Instruction Manual herein always states to that effect.
- **Be sure to ground the Earth Terminal** (this, however, is not required in the case where a power cord with earth is used).  
This product is equipped with the Earth Terminal. When installing the product, Connect the Earth Terminal to the “accurately grounded indoor earth terminal” by using an earth wire. Unless the product is grounded appropriately, the user can be subject to electric shock. After performing repair, etc. for the Control equipment, ensure that the Earth Wire is firmly connected to the Control equipment.
- **Ensure that the Power Supply used is equipped with an Earth Leakage Breaker.**  
This product does not incorporate the Earth Leakage Breaker. Using a power supply which is not equipped with the Earth Leakage Breaker can cause a fire when earth leakage occurs.
- **Be sure to use fuses which meet the specified rating.** (only for the machines which use fuses).  
Using fuses exceeding the specified rating can cause a fire and electric shock.

- **Specification changes (removal of equipment, conversion and addition) not designated by SEGA are not allowed.**  
The parts of the product include warning labels for safety, covers for personal protection, etc. It is very hazardous to operate the product by removing parts and or modifying the circuits. Should doors, lids and protective parts be damaged or lost, refrain from operating the product, and contact where the product was purchased from or the office herein stated. SEGA shall not be held responsible for any accidents, compensation for damage to a third party, resulting from the specifications not designated by SEGA.
  - **Ensure that the product meets the requirements of appropriate Electrical Specifications.**  
Before installing the product, check for Electrical Specifications. SEGA products have a nameplate on which Electrical Specifications are described. Ensure that the product is compatible with the power supply voltage and frequency requirements of the location. Using any Electrical Specifications different from the designated Specifications can cause a fire and electric shock.
  - **Install and operate the product in places where appropriate lighting is available, allowing warning labels to be clearly read.**  
To ensure safety for the customers, labels and printed instructions describing potentially hazardous situation are applied to places where accidents can be caused. Ensure that where the product is operated has sufficient lighting allowing the warnings to be read. If any label is peeled off, apply it again immediately. Please place an order with where the product was purchased from or the office herein stated.
  - **When handling the Monitor, be very careful. (Applies only to the product w/monitor.)**  
Some of the monitor (TV) parts are subject to high tension voltage. Even after running off power, some portions are still subject to high tension voltage sometimes. Monitor repair and replacement should be performed only by those technical personnel who have knowledge of electricity and technical expertise.
  - **Be sure to adjust the monitor (projector) properly. (Applies only to the product w/monitor.)**  
Do not operate the product leaving on-screen flickering or blurring as it is. Using the product with the monitor not properly adjusted may cause dizziness or a headache to an operator, a player, or the customers.
  - **When transporting or reselling this product, be sure to attach this manual to the product.**  
In the case where commercially available monitors and printers are used in this product, only the contents relating to this product are explained herein. Some commercially available equipment has functions and reactions not stated in this manual. Read this manual together with the specific Instruction Manual of such equipment.
- Descriptions herein contained may be subject to improvement changes without notice.
  - The contents described herein are fully prepared with due care. However, should any question arise or errors be found, please contact SEGA.

#### **INSPECTIONS IMMEDIATELY AFTER TRANSPORTING THE PRODUCT TO THE LOCATION.**

Normally, at the time of shipment, SEGA products are in a status allowing for usage immediately after transporting to the location. Nevertheless, an irregular situation may occur during transportation. Before turning on power, check the following points to ensure that the product has been transported in a satisfactory status.

- Are there any dented portions or defects (cuts, etc.) on the external surfaces of the cabinet?
- Are Casters and Adjusters, damaged?
- Do the power supply voltage and frequency requirements meet with those of the location?
- Are all wiring connectors correctly and securely connected? Unless connected in the correct direction, connector connections can not be made accurately. Do not insert connectors forcibly.
- Do power cords have cuts and dents?
- Do the fuses used meet specified rating? Is the Circuit Protector in an energized status?
- Are all accessories available?
- Can all Doors and Lids be opened with the Accessory keys? Can Doors and Lids be firmly closed?

---

---

## TABLE OF CONTENTS

---

---

BEFORE USING THE PRODUCT, BE SURE TO READ THE FOLLOWING:

TABLE OF CONTENTS

INTRODUCTION OF THE OWNER'S MANUAL

1. HANDLING PRECAUTIONS .....	1
2. PRECAUTIONS CONCERNING INSTALLATION LOCATION .....	2 - 3
3. OPERATION .....	4 - 7
4. ACCESSORIES .....	8 - 10
5. ASSEMBLING AND INSTALLATION .....	11 - 18
6. PRECAUTIONS TO BE HEDED WHEN MOVING THE MACHINE .....	19
7. CONTENTS OF GAME .....	20 - 24
8. EXPLANATION OF TEST AND DATA DISPLAY .....	25 - 52
8 - 1 SWITCH UNIT AND COIN METER .....	27 - 28
8 - 2 SYSTEM TEST MODE .....	29 - 41
8 - 3 GAME TEST MODE .....	42 - 52
9. CONTROL PANEL (ASSY HANDLE MECHA) .....	53 - 57
9 - 1 ADJUSTING/REPLACING THE V.R. ....	53 - 55
9 - 2 GREASING .....	56
10. SPEED SHIFTER (SHIFT LEVER).....	57 - 59
10 - 1 REMOVING THE 4-SPEED SHIFTER .....	57 - 58
10 - 2 REPLACING THE SWITCH .....	59
11. PEDAL DUAL .....	60 - 61
11 - 1 ADJUSTING AND REPLACING THE V.R. ....	60 - 61
11 - 2 GREASING .....	61
12. COIN SELECTOR .....	62 - 65
13. REPLACING THE FLOURESCENT LAMP, AND LAMPS .....	66 - 67
14. PERIODIC INSPECTION TABLE .....	68
15. TROUBLESHOOTING .....	69 - 70
16. GAME BOARD .....	71 - 74
16 - 1 REMOVING THE GAME BOARD .....	72 - 73
16 - 2 COMPOSITION OF GAME BOARD .....	74
17. COMMUNICATION PLAY .....	75 - 80
17 - 1 INSTALLATION PRECAUTIONS .....	75 - 76
17 - 2 CONNECTING THE COMMUNICATION CABLE .....	76 - 78
17 - 3 SETTING FOR COMMUNICATION PLAY .....	79 - 80
18. DESIGN RELATED PARTS .....	81 - 82
19. PARTS LIST .....	83 - 97
20. WIRE COLOR CODE TABLE .....	98
21. WIRING DIAGRAM .....	XXX

---

---

## SPECIFICATIONS

Installation Space	: 41.75 inches width X 73 inches
Height	: 73.5 inches
Width	: 31.75 inches
Length	: 71.25 inches
Weight	: 825 lbs
Power, maximum current	: 330 W 2.75 A (AC 120V 60 Hz AREA)

MONITOR : 29 inch supplied by Wells Gardner  
model #wgm-2972-UOT-529K

## INTRODUCTION OF THE OWNERS MANUAL

This Owner's Manual is intended to provide detailed descriptions together with all the necessary information covering the general operation of electronic assemblies, electromechanicals, servicing control, spare parts, etc. as regards the product,

### **EA SPORTS NASCAR MINI STANDARD TYPE.**

This manual is intended for the owners, personnel and managers in charge of operation of the product. Operate the product after carefully reading and sufficiently understanding the instructions. If the product fails to function satisfactorily, non-technical personnel should under no circumstances touch the internal system. Please contact where the product was purchased from.

Use of this product is unlikely to cause physical injuries or damages to property. However, where special attention is required this is indicated by a thick line, the word "IMPORTANT" and its sign in this manual.



Indicates that mishandling the product by disregarding this display can cause the product's intrinsic performance not to be obtained, resulting in malfunctioning.

**IMPORTANT!**

SEGA ENTERPRISES, INC. (U.S.A.)/CUSTOMER SERVICE  
45133 Industrial Drive, Fremont, California 94538, U.S.A.  
Phone : (415) 701-6580  
Fax : (415) 701-6594

## DEFINITION OF LOCATION MAINTENANCE MAN AND SERVICEMAN



Non-technical personnel who do not have technical knowledge and expertise should refrain from performing such work that this manual requires the location's maintenance man or a serviceman to carry out, or work which is not explained in this manual. Failing to comply with this instruction can cause a severe accident such as electric shock.

Ensure that parts replacement, servicing & inspections, and troubleshooting are performed by the location's maintenance man or the serviceman. It is instructed herein that particularly hazardous work should be performed by the serviceman who has technical expertise and knowledge.

The location's maintenance man and serviceman are herein defined as follows:

### **"Location's Maintenance Man" :**

Those who have experience in the maintenance of amusement equipment and vending machines, etc., and also participate in the servicing and control of the equipment through such routine work as equipment assembly and installation, servicing and inspections, replacement of units and consumables, etc. within the Amusement Facilities and or locations under the management of the Owner and Owner's Operators of the product.

### **Activities of Location's Maintenance Man :**

Assembly & installation, servicing & inspections, and replacement of units & consumables as regards amusement equipment, vending machines, etc.

### **Serviceman :**

Those who participate in the designing, manufacturing, inspections and maintenance service of the equipment at an amusement equipment manufacturer.

Those who have technical expertise equivalent to that of technical high school graduates as regards electricity, electronics and or mechanical engineering, and daily take part in the servicing & control and repair of amusement equipment.

### **Serviceman's Activities :**

Assembly & installation and repair & adjustments of electrical, electronic and mechanical parts of amusement equipment and vending machines.

**LISTED**



**5K92**

**AMUSEMENT MACHINE**

# 1. HANDLING PRECAUTIONS

When installing or inspecting the machine, be very careful of the following points and pay attention to ensure that the player can enjoy the game safely.

Non-compliance with the following points or inappropriate handling running counter to the cautionary matters herein stated can cause personal injury or damage to the machine.



- Before performing work, be sure to turn power off. Performing the work without turning power off can cause an electric shock or short circuit. In the case work should be performed in the status of power on, this manual always states to that effect.
- To avoid electric shock or short circuit, do not plug in or unplug quickly.
- To avoid electric shock, do not plug in or unplug with a wet hand.
- Do not expose Power Cords and Earth Wires on the surface, (floor, passage, etc.). If exposed, the Power Cords and Earth Wires are susceptible to damage. Damaged cords and wires can cause electric shock or short circuit.
- To avoid causing a fire or electric shock, do not put things on or damage Power Cords.
- When or after installing the product, do not unnecessarily pull the power cord. If damaged, the power cord can cause a fire or electric shock.
- In case the power cord is damaged, ask for replacement through where the product was purchased from or the office herein stated. Using the cord as is damaged can cause fire, electric shock or leakage.
- Be sure to perform grounding appropriately. Inappropriate grounding can cause an electric shock.
- Be sure to use fuses meeting specified rating. Using fuses exceeding the specified rating can cause a fire or electric shock.
- Completely make connector connections for IC BD and others. Insufficient insertion can cause an electric shock.
- Specification changes, removal of equipment, conversion and/or addition, not designated by SEGA are not permitted.
  - Failure to observe this may cause a fire or an electric shock. Non-compliance with this instruction can have a bad influence upon physical conditions of the players or the lookers-on, or result in injury during play.
  - SEGA shall not be held responsible for damage, compensation for damage to a third party, caused by specification changes not designated by SEGA.
- Be sure to perform periodic maintenance inspections herein stated.



- For the IC board circuit inspections, only the logic tester is allowed. The use of a multiple-purpose tester is not permitted, so be careful in this regard.



## 2. PRECAUTIONS CONCERNING INSTALLATION LOCATION



This product is an indoor game machine. Do not install it outside. Even indoors, avoid installing in places mentioned below so as not to cause a fire, electric shock, injury and or malfunctioning.

- Places subject to rain or water leakage, or places subject to high humidity in the proximity of an indoor swimming pool and or shower, etc.
- Places subject to direct sunlight, or places subject to high temperatures in the proximity of heating units, etc.
- Places filled with inflammable gas or vicinity of highly inflammable/volatile chemicals or hazardous matter.
- Dusty places.
- Sloped surfaces.
- Places subject to any type of violent impact.
- Vicinity of anti-disaster facilities such as fire exits and fire extinguishers.
- The operating (ambient) temperature range is from 5 C° to 40 C°.
- Only in the case a projector is employed, the temperature range is from 5 C° to 30 C°.

### LIMITATIONS OF USAGE REQUIREMENTS



- Be sure to check the Electrical Specifications.
- Ensure that this product is compatible with the location's power supply, voltage and frequency requirements.
- A plate describing Electrical Specifications is attached to the product.
- Non-compliance with the Electrical Specifications can cause a fire and electric shock.
- This product requires the Breaker and Earth Mechanisms as part of the location facilities. Using them in a manner not independent can cause a fire and electric shock.
- Ensure that the indoor wiring for the power supply is rated at 15A or higher (AC single phase 100 ~ 120V area), and 7A or higher (AC 220 ~ 240V area).
- Non-compliance with the Electrical Specifications can cause a fire and electric shock.
- Be sure to independently use the power supply equipped with the Earth Leakage Breaker. Using a power supply without the Earth Leakage Breaker can cause an outbreak of fire when earth leakage occurs.
- Putting many loads on one electrical outlet can cause generation of heat and a fire resulting from overload.
- When using an extension cord, ensure that the cord is rated at 15A or higher (AC 100 ~ 120V area) and 7A or higher (AC 220 ~ 240V area). Using a cord rated lower than the specified rating can cause a fire and electric shock.

OPERATION AREA



- For the operation of this machine, secure a minimum area of 41 inches (W) X 73 inches (D). In order to prevent injury resulting from the falling down accident during game play, be sure to secure the minimum area for operation.
- Be sure to provide sufficient space so as to allow this product's ventilation fan to function efficiently. To avoid machine malfunctioning and a fire, do not place any obstacles near the ventilation opening.
- SEGA shall not be held responsible for damage, compensation for damage to a third party, resulting from the failure to observe this instruction.



For transporting the machine into the location's building, the minimum necessary dimensions of the opening (of doors, etc.) are 33 inches (W) and 74 inches (H).

Electric current consumption

120 VAC  
5 A

### 3. OPERATION

#### PRECAUTIONS TO BE HEEDED BEFORE STARTING THE OPERATION

To avoid injury and trouble, be sure to constantly give careful attention to the behavior and manner of the visitors and players.



In order to avoid accidents, check the following before starting the operation:

- To ensure maximum safety for the players and the customers, ensure that where the product is operated has sufficient lighting to allow any warnings to be read. Operation under insufficient lighting can cause bodily contact with each other, hitting accident, and or trouble between customers.
- It is suggested to ensure a space allowing the players who feel sick while playing the game to take a rest.



Ensure that all of the Adjusters are in contact with the floor.



- Do not put any heavy item on this product. Placing any heavy item on the product can cause a falling down accident or parts damage.
- Do not climb on the product. Climbing on the product can cause falling down accidents. To check the top portion of the product, use a step.
- To avoid electric shock, check to see if door & cover parts are damaged or omitted.
- To avoid electric shock, short circuit and or parts damage, do not put the following items on or in the periphery of the product.
- Flower vases, flowerpots, cups, water tanks, cosmetics, and receptacles/containers/vessels containing chemicals and water.



To avoid injury, be sure to provide sufficient space by considering the potentially crowded situation at the installation location. Insufficient installation space can cause making bodily contact with each other, hitting accidents, and or trouble between customers.

#### PRECAUTIONS TO BE HEEDED DURING OPERATION (PAYING ATTENTION TO CUSTOMERS)

To avoid injury and trouble, be sure to constantly give careful attention to the behavior and manner of the visitors and players.



- To avoid injury and accidents, those who fall under the following categories are not allowed to play the game.
  - Those who need assistance such as the use of an apparatus when walking.
  - Those who have high blood pressure or a heart problem.
  - Those who have experienced muscle convulsion or loss of consciousness when playing video game, etc.
  - Those who have a trouble in the neck and or spinal cord.
  - Intoxicated persons.
  - Pregnant women or those who are in the likelihood of pregnancy.
  - Persons susceptible to motion sickness.
  - Persons whose act runs counter to the product's warning displays.
- A player who has never been adversely affected by light stimulus might experience dizziness or headache depending on his physical condition when playing the game. Especially, small children can be subject to those conditions. Caution guardians of small children to keep watch on their children during play.
- Instruct those who feel sick during play to have a medical examination.
- To avoid injury resulting from falling down and electric shock due to spilled drinks, instruct the player not to place heavy items or drinks on the product.
- To avoid electric shock and short circuit, do not allow customers to put hands and fingers or extraneous matter in the openings of the product or small openings in or around the doors.
- To avoid falling down and injury resulting from falling down, immediately stop the customer's leaning against or climbing on the product, etc.
- To avoid electric shock and short circuit, do not allow the customers to unplug the power plug without a justifiable reason.



**WARNING: HAZARD TO EPILEPTICS.**

- A very small portion of the population has a condition which may cause them to experience epileptic seizures or have momentary loss of consciousness when viewing certain kinds of flashing lights or patterns that are present in our daily environment. These persons may experience seizures while watching some kinds of television pictures or playing certain video games. People who have not had any previous seizures may nonetheless have an undetected epileptic condition.
- If you or anyone in your family has experienced symptoms linked to an epileptic condition (e.g., seizures or loss of awareness), immediately consult your physician before using any video games.
- We recommend that parents observe their children while they play video games. If you or your child experience the following symptoms: dizziness, altered vision, eye or muscle twitching, involuntary movements, loss of awareness, disorientation, or convulsions, **DISCONTINUE USE IMMEDIATELY** and consult your physician.



- Caution lookers-on so as not to touch the operating unit while in play. Failure to observe this may cause bodily contact with the player and trouble between the customers.

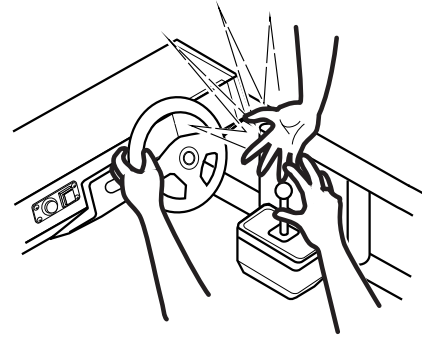

- Caution the player so as not to hold a child in her/his lap to play. Failure to observe this may cause the child to be caught between the Control Panel and the player and fall down.

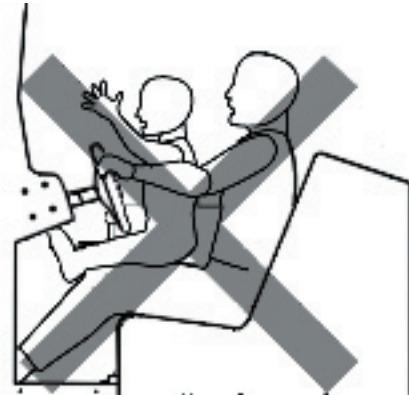

- Immediately stop such violent acts as hitting and kicking the product. Such violent acts can cause parts damage or falling down, resulting in injury due to fragments and falling down.
- Instruct the Player to adjust the seat before playing the game. Playing the game in a forcible posture can cause a contingent accident.

# 4. ACCESSORIES

When transporting the machine, make sure that the following parts are supplied.

TABLE 4 ACCESSORIES

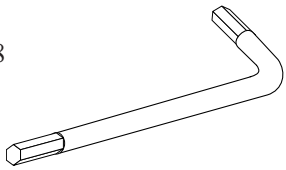
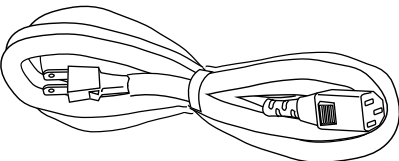
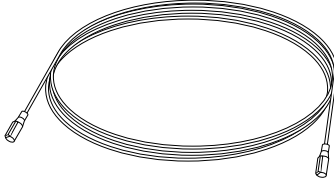
DESCRIPTION	OWNERS MANUAL		
Part No. (Qty.)	999 - 1429 (1)		
Note			
Figures			
If Part No. has no description, the Number has not been registered or can not be registered. Such a part may not be obtainable even if the customer desires to purchase it. Therefore, ensure that the part is in safekeeping with you.			
		KEY MASTER (2) For opening/closing the doors	KEY (2) For the CASHBOX DOOR  The Keys are inside the Coin Chute Door at the time of shipment from the factory.
TAMPERPROOF†WRENCH T-15 TORX 8-32 T-40 TORX 5/16-18			AC Cable (Power Cord) Used for installation, See <span style="border: 1px solid black; padding: 0 2px;">4</span> of Section 5.
			
ASSY FIBER CABLE 600-6275-0500 (1) For communication play, refer to Section 17.			
			

NUMBER STICKER(for rear)

999-1082(1)

For communication play,  
refer to Section 17.

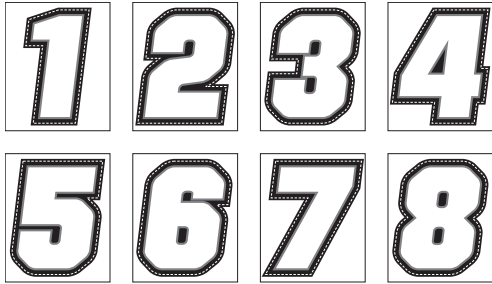

NUMBER STICKER(for side)

999-1081 (1)

For communication play,  
refer to Section 17.

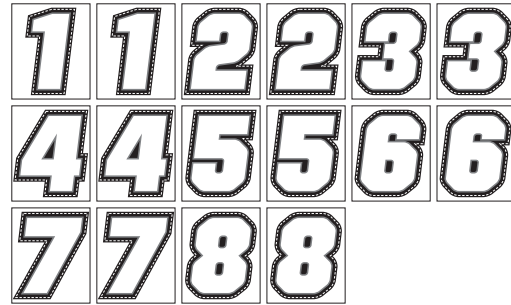

CARTON BOX

601-10642 (1)

Used for transporting the  
Game Board.  
Refer to Next Page.

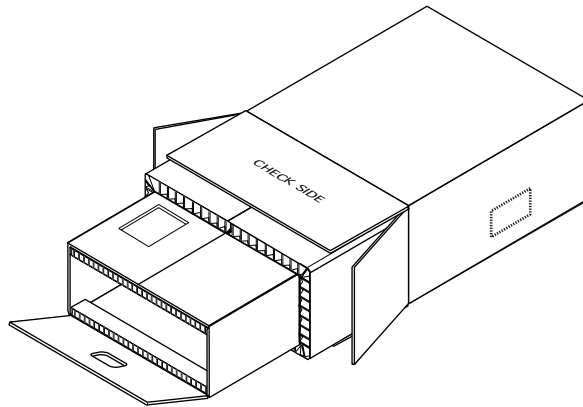



## HOW TO USE THE CARTON BOX



- When asking for the replacement or repair of the product's Game Board (SEGA HIKARU), be sure to put the Game Board together with the Shield Case in a Carton Box. Otherwise, the request is not acceptable.
- Put the Shield Case in the Carton Box by paying attention to the correct direction as per the following instructions and as shown by the instructions printed on the Carton Box. Handling in an erroneous manner can damage the Game Board.
- Remove the Shield Case Brackets from the Shield Case and put the Shield Case in the Carton Box.

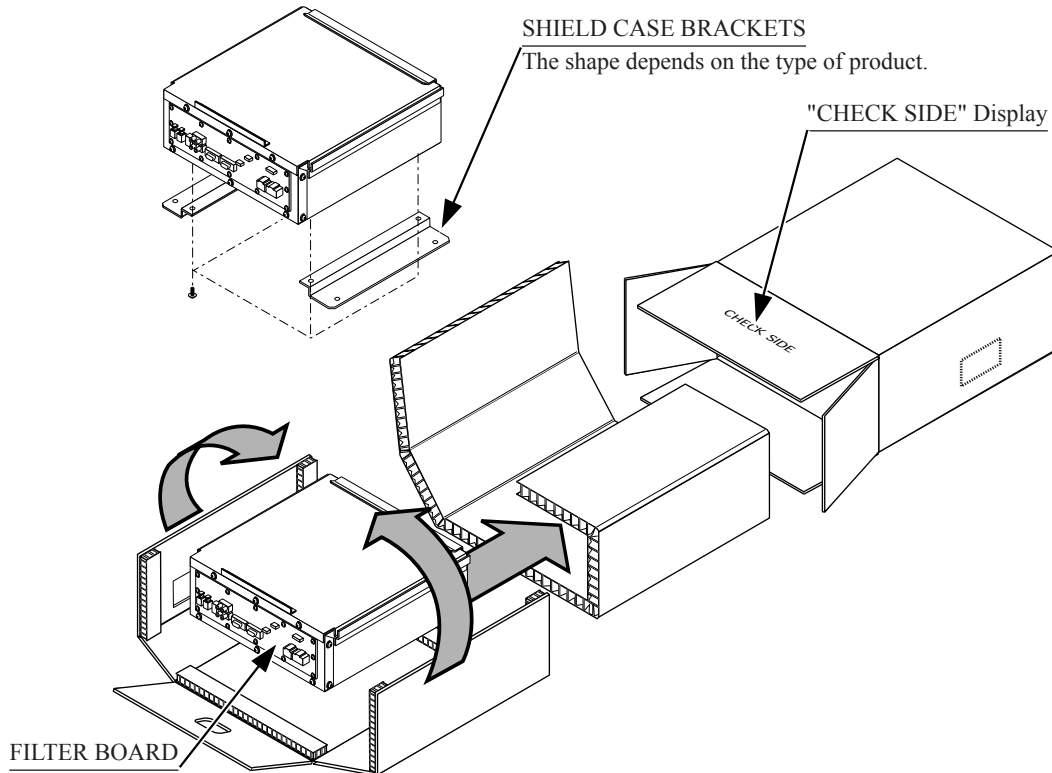

Wrap the Shield Case with the packing material and put it in the Carton Box as shown. Putting it upside down or packing otherwise in the manner not shown can damage the Game Board and parts.

## 5. ASSEMBLING AND INSTALLATION



- Perform assembly work by following the procedure herein stated. Failing to comply with the instructions can cause electric shock hazard.
- Perform assembling as per this manual. Since this is a complex machine, erroneous assembling can cause an electric shock, machine damage and or not functioning as per specified performance.
- When assembling, be sure to use plural persons. Depending on the assembly work, there are some cases in which working by one person alone can cause personal injury or parts damage.
- Ensure that connectors are accurately connected. Incomplete connections can cause electric shock hazard.
- Be careful so as not to damage wirings. Damaged wiring can cause electric shock and short circuit hazards.
- This work should be performed by the Location's Maintenance Man or Serviceman. Performing work by non-technical personnel can cause a severe accident such as electric shock. Failing to comply with this instruction can cause a severe accident such as electric shock to the player during operation.
- Provide sufficient space so that assembling can be performed. Performing work in places with narrow space or low ceiling may cause an accident and assembly work to be difficult.
- To perform work safely and avoid serious accident such as the cabinet's falling down, do not perform work in places where step-like grade differences, a ditch, or slope exist.



To perform work safely and securely, be sure to prepare a step which is in a secure and stable condition. Performing work without using the step can cause violent falling down accidents.

When carrying out the assembling and installation, follow the following 6-item sequence.

- 1 SECURING IN PLACE (ADJUSTER ADJUSTMENT)
- 2 POWER SUPPLY CONNECTION
- 3 TURNING POWER ON
- 4 ASSEMBLING CHECK

The master key (accessories) in addition to the tools such as a Phillips type screwdriver, wrench, socket wrench and Ratchet Handle are required for the assembly work.

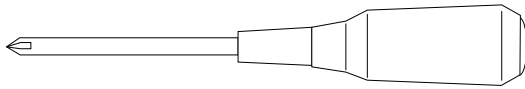

Phillips type screwdriver

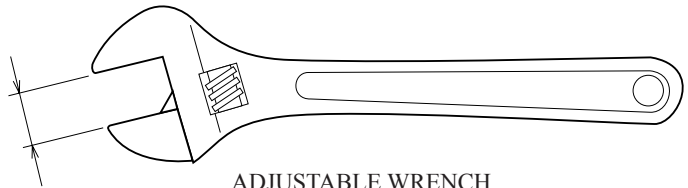

ADJUSTABLE WRENCH

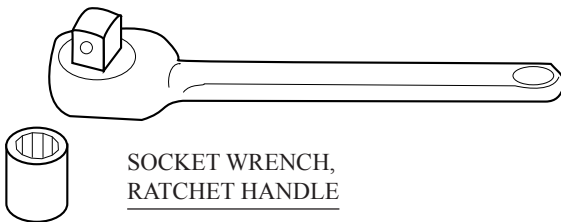

SOCKET WRENCH,  
RATCHET HANDLE

KEY MASTER

# 1 SECURING IN PLACE (ADJUSTER ADJUSTMENT)



Make sure that all of the adjusters are in contact with the floor. If they are not, the cabinet can move and cause an accident.

This product has 6 casters and 6 Adjusters. (FIG. 5. 3a) When the installation position is determined, cause the adjusters to come into contact with the floor directly, make adjustments in a manner so that the casters will be raised approximately 5mm. from the floor and make sure that the machine position is level.

- 1 Transport the product to the installation position. Be sure to provide adequate space allowing the player to get on and off.
- 2 Have all of the Adjusters make contact with the floor. Adjust the Adjuster's height by using a wrench so that the machine position is kept level.
- 3 After making adjustment, fasten the Adjuster Nut upward and secure the height of Adjuster (FIG. 5. 3 b).

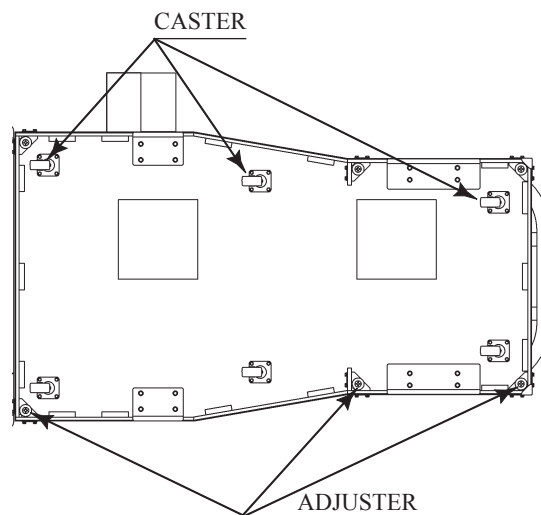

FIG. 5. 3 a BOTTOM VIEW

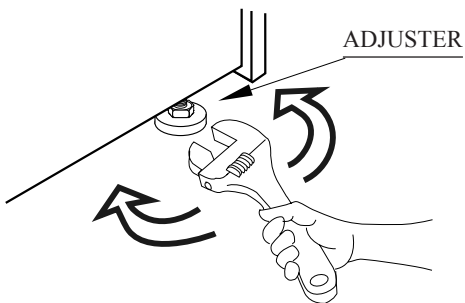
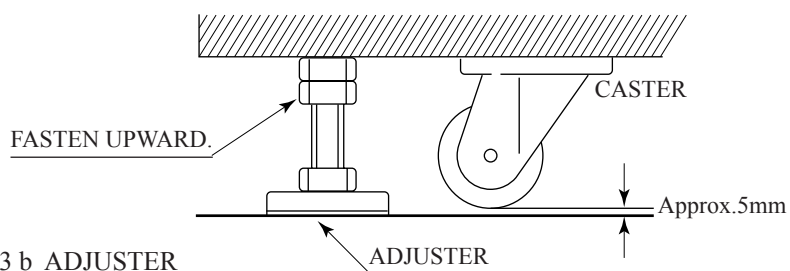

FIG. 5. 3 b ADJUSTER



## 2

## POWER SUPPLY, AND EARTH CONNECTION



- Be sure to independently use the power supply socket outlet equipped with an Earth Leakage Breaker. Using a power supply without an Earth Leakage Breaker can cause a fire when electric leakage occurs.
- Ensure that the "accurately grounded indoor earth terminal" and the earth wire cable are available (except in the case where a power cord plug with earth is used). This product is equipped with the earth terminal. Connect the earth terminal and the indoor earth terminal with the prepared cable. If the grounding work is not performed appropriately, customers can be subjected to an electric shock, and the product's functioning may not be stable.
- Ensure that the power cord and earth wire are not exposed on the surface (passage, etc.). If exposed, they can be caught and are susceptible to damage. If damaged, the cord and wire can cause electric shock and short circuit accidents. Ensure that the wiring position is not in the customer's passage way or the wiring has protective covering.
- After wiring power cord on the floor, be sure to protect the power cord. Exposed power cord is susceptible to damage and causes an electric shock accident.

The AC Unit is mounted on the right side of the machine. The AC Unit has Main SW, Circuit Protector, Earth Terminal and the Inlet which connects the Power Cord.

- ① Ensure that the Main SW is OFF.

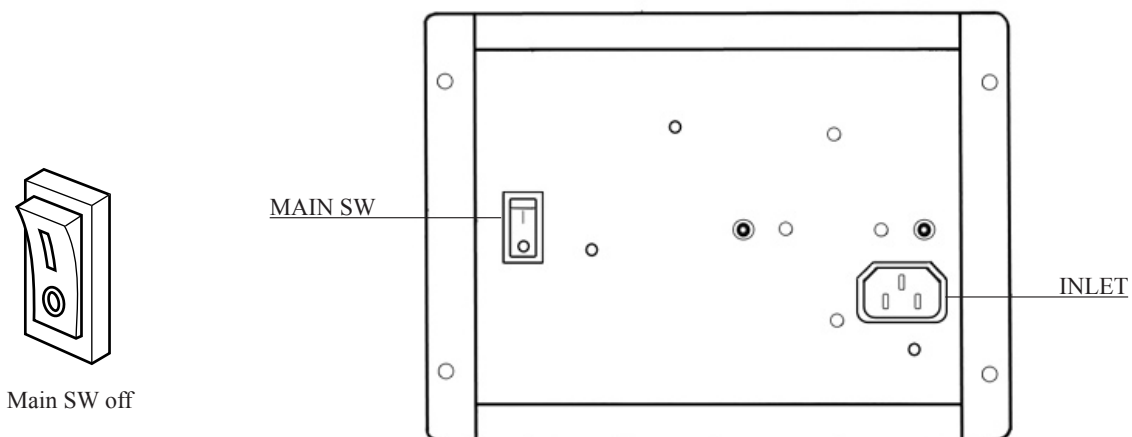
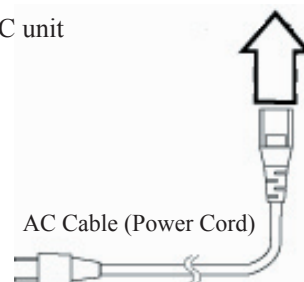

FIG. 5. 4 a AC unit



# 3

## TURNING POWER ON

Connect the power by turning on the AC unit's main switch. Then the billboard's fluorescent light comes on.

The monitor displays a system power-on message, and then an advertising screen (a plying-for-hire screen) appears. At the same time the right and left speakers on the control panel output an advertise sound. The sound is inaudible, however, when you have disabled its function.

Before an advertising screen appears the system automatically conducts an initialization. Do not touch the product until the system completes an initialization and the advertising screen appears.

During an initialization the handle (steering wheel) turns counterclockwise and clockwise and stops at the original center position (for a straight-ahead direction). This corrects the volume value inside the control panel. Do not touch the handle or play the game before an initialization is completed (that is, the handle automatically stops at the center position). Failure to observe this may affect the handle's operability and the handle's force feedback (force feedback against crashing) during playing the game. If the handle's operability or force feedback is abnormal, disconnect and reconnect the power for initializing the system again.

When you disconnect the power, the system saves the data for the credit number, ranking, and latest game's score. Assume that the credits effective for playing a game remain when you disconnect the power. In this case, when you will reconnect the power a game startup screen will appear with the start button flashing.

If several machines are interconnected or networked for a communication play, the system checks the network. A network-checking screen as illustrated below appears before an advertising screen appears. Usually, checking the network takes 1 to 3 minutes. If the system detects a problem related with the network, it keeps displaying the network-checking screen or an error message.

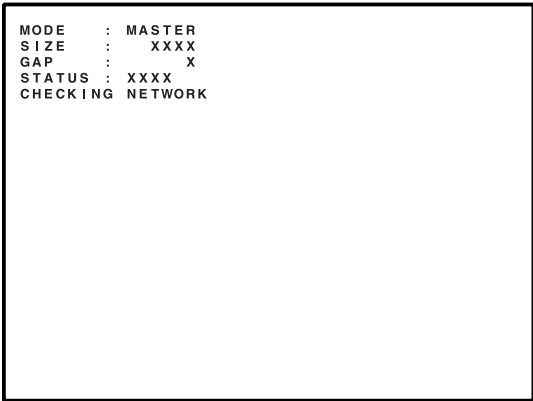

FIG. 5. 5 b NETWORK check screen



### (3) SOUND TEST

```
SOUND TEST

MAIN SPEAKER LEFT
MAIN SPEAKER RIGHT
OPTION SPEAKER LEFT
OPTION SPEAKER RIGHT
> EXIT

SELECT WITH SERVICE BUTTON
AND
PRESS TEST BUTTON
```

In the system test mode, selecting SOUND TEST causes the screen (on which sound related BD and wiring connections are tested) to be displayed. Check if the sound is satisfactorily emitted from each speaker and the sound volume is appropriate.

### (4) INPUT TEST

```
INPUT TEST

STEERING WHEEL      XXX
GAS PEDAL            XXX
BRAKE PEDAL          XXX
GEAR POSITION          ON
START BUTTON         OFF
VIEW CHANGE BUTTON  OFF

SERVICE SWITCH      OFF
TEST SWITCH          OFF

PRESS TEST AND SERVICE BUTTON TO EXIT
```

Selecting the INPUT TEST on the game test mode menu screen causes the screen (on which each switch is tested) to be displayed. Press each switch. For the coin switch test, insert a coin from the coin inlet with the coin chute door open. If the display beside each switch indicates "ON," the switch and wiring connections are satisfactory.

```
JVS TEST
>DISPLAY CONFIG
EXIT

NODE 1/1
SWITCH
SYSTEM _____
PLAYER1 _____
PLAYER2 _____
COIN
SLOT1 0000 SLOT2 8000
ANALOG
CH1 0000 CH2 0000 CH3 0000 CH4 0000
CH5 0000 CH6 0000 CH7 0000 CH8 0000

SELECT WITH SERVICE BUTTON
AND
PRESS TEST BUTTON
```



(5) OUTPUT TEST

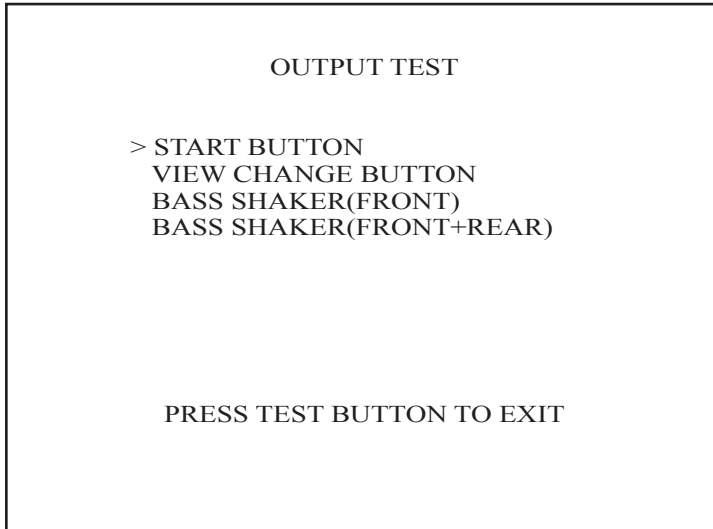

Select OUTPUT TEST from the Menu screen in the Game Test Mode to cause the screen (on which output unit such as lamps and wiring connections are tested) to appear. Ensure that the output unit functions satisfactorily.

Perform the above inspections also at the time of monthly inspection.

## 6. PRECAUTIONS TO BE HEEDED WHEN MOVING THE MACHINE



- When moving the machine, be sure to unplug the power plug. Moving the machine with the plug as is inserted can damage the power cord and cause fire and electric shock hazards.
- When moving the machine on the floor, retract the Adjusters and ensure that Casters make contact with the floor. During transportation, pay careful attention so that Casters do not tread power cords and earth wires. Damaging the power cords can cause electric shock and short circuit hazards.
- When lifting the cabinet, be sure to hold the grip portions or bottom part. Lifting the cabinet by holding other portions can damage parts and installation portions due to the empty weight of the cabinet, and cause personal injury.
- When transporting the product in places with step-like differences in grade, disassemble into each unit before transporting. Lifting up the product in an attempt to cross the step-like differences in an as is assembled condition may damage the unit's joining portions and cause a personal injury resulting from damage.
- Do not insert the fork to places other than designated when using a Forklift to transport the machine.
- Failure to observe this could cause falling down and injury resulting from falling down.



- Do not push the plastic made parts. Failure to observe this may damage parts and cause injury due to fragments resulting from damage.
- Do not use the handle or lever to move the product. Failure to observe this may cause the parts to be deformed or damaged.



- When transporting the product in places with steps, disassemble into each unit before transporting. Inclining the product in an as is assembled condition or placing the cabinet in places with steps can damage the unit's joining portions.
- To protect surface, do not directly apply a rope to the surfaces of product. Use protective materials to the places the rope is applied to.

## 7. CONTENTS OF GAME

The following explanations apply to the case the product is functioning satisfactorily. Should there be any moves different from the following contents, some sort of faults may have occurred. Immediately look into the cause of the fault and eliminate the cause thereof to ensure satisfactory operation.

### Advertising (Plying-for-Hire) Performance

The billboard's fluorescent light is always on when the power is connected.  
The monitor displays the demonstration images and ranking data. The ranking data is updated every week.  
The lights (integrated with the two buttons on the control panel) are off.  
The right and left speakers under the Marquee output an advertise sound.  
You can activate or deactivate an advertise sound output function on the test mode screen.



FIG. 7 a

## HOW TO PLAY

Operation of a single machine allows a Single Play. Operation of interconnected machines allows a Communication Play.



[Single Play]

FIG. 7 b

- ① Sit down on the seat. You can slide the seat back and forth. Facing the screen you can find the seat lock lever on the seat's right bottom. Pull it to unlock and slide the seat.
- ② Insert coins, and then the corresponding credit number appears on the screen's bottom left. When you insert the coins enough for one play, the credit number disappears and a SELECT screen appears.
- ③ TRACK SELECT, CAR SELECT, and TRANSMISSION SELECT screens appear in this order. Turn the handle counterclockwise and clockwise for moving around the items, and press the gas pedal (accelerator) for selecting an item. The number is counted down at the upper right corner of the SELECT screens while you are moving around the items. When the time is counted out to 0 (zero), the system automatically selects the item (track/car/transmission) wherever you are at that time. If you select any item on the current screen, it disappears and the next screen appears even while the time is still counted down.

TRACK SELECT screen



CAR SELECT screen



- ④ After you select a transmission, the race starts. If you press the view change button on the TRANSMISSION SELECT screen, you can activate a time attack mode.

TRANSMISSION SELECT screen



● Rules with Time Attack Mode

You drive a car alone to compete in the lap time. You must cycle the course within a limited time. If you succeed to cycle the course within a limited time, the remaining time is added to the limited time of a next cycling. If you clear the specified number of cycling times, the game is finished. If you fail to cycle the course within a limited time, the game is over.

- ⑤ You start last. You must cycle the course within a limited time. If you succeed to cycle the course within a limited time, the remaining time is added to the limited time of a next cycling.

- ⑥ If you succeed to overtake the preceding cars and thereby reach a target position, the bonus time is added to the limited time. The target position is eventually carried up.

- ⑦ If you clear the specified number of cycling times, the game is finished. If you fail to cycle the course within a limited time, the game is over.



- ⑧ The handle gives a force feedback when your car touches the course walls or other cars, or is off the course.
- ⑨ If you press the view change button, you can change the viewpoint. After pressing the button, its integrated light flashes for several seconds.
- ⑩ When the game is finished or over, the system automatically opens the TRACK SELECT screen only if playable credits remain at that time.

## [Communication Play]

Starting/playing procedures of a communication play are different from those of a single play.

- ① When a player inserts the coins enough for one play, an entry screen appears. At the same time the start button flashes.
- ② A player who wants a communication play must insert the coins (enough for one communication play) into the separate coin chute slot. A player who wants a single play must press the start button immediately when an entry screen appears.
- ③ When an entry screen appears, the system starts counting down the time. If there are no competitors and the time is counted out to 0 (zero), only a single play is available.
- ④ If there are some competitors and the time is counted out to 0 (zero), the TRACK SELECT screen appears. Turn the handle counterclockwise and clockwise for moving around the items and press the gas pedal (accelerator) for selecting an item. The track is decided by majority of the players.



- ⑤ Next to the TRACK SELECT screen, the CAR SELECT and TRANSMISSION SELECT screens appear in this order. Again, turn the handle counterclockwise and clockwise for moving around the items and press the gas pedal (accelerator) for selecting an item.
- ⑥ On the NAME ENTRY screen, too, turn the handle counterclockwise and clockwise for moving around the items and press the gas pedal (accelerator) for selecting a character.

The number is counted down at the upper right corner of the SELECT screens and the NAME ENTRY screen while you are moving around the items. When the time is counted out to 0 (zero), the system automatically selects the item (car/transmission) wherever a player is at that time.

If a player selects any item on the current screen, it disappears and the next screen appears even while the time is still counted down.

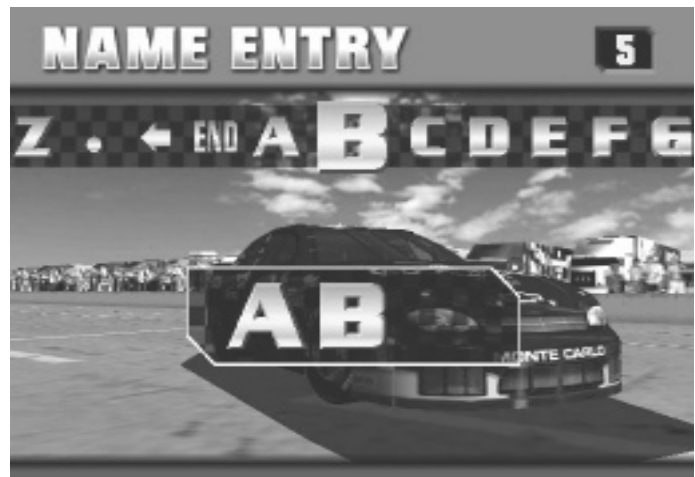

SELECT WITH WHEEL & CONFIRM WITH PEDAL

- ⑦ When the number is counted out to 0 (zero) on the NAME ENTRY screen, the race starts.

- ⑧ Players compete with each other in the position. The top player can add the time remained after a cycling to the limited time of a next cycling.
- ⑨ When the top player clears the specified number of cycling times, the game is finished. If a player fails to cycle the course within a limited time, the game is over.



## 8. EXPLANATION OF TEST AND DATA DISPLAY

By operating the switch unit, periodically perform the tests and data check. When installing the machine initially or collecting cash, or when the machine does not function correctly, perform checking in accordance with the explanations given in this section.

The following shows tests and modes that should be utilized as applicable.

SEGA HIKARU GAME BOARD is used for the product. The system of this game board allows another game to be played by replacing the ROM Board Case mounted on the SEGA HIKARU CASE. As such, the Test Mode of this system consists of the System Test Mode for the system to execute SELF-TEST, COIN ASSIGNMENTS, etc. used in common for the machines employing the SEGA HIKARU BOARD, and the Game Test Mode for the specific product to execute Input/Output test for the operation equipment, difficulty setting, etc.



- The contents of settings changed in the TEST mode are stored when the test mode is finished from EXIT in the menu mode. If the power is turned off before the TEST mode is finished, the contents of setting change become ineffective.
- Executing "BACKUP DATA CLEAR" in the SYSTEM TEST MODE does not clear the BOOKKEEPING data in the GAME TEST mode.
- Entering the TEST mode clears fractional number of coins less than one credit and BONUS ADDER data.
- When the 2 or more machines are linked for communication play, be careful to enter the test mode. If one of the machines linked enters the test mode, all others display the NETWORK CHECK screen.



TABLE 8 EXPLANATION OF TEST MODE

ITEMS	DESCRIPTION	REFERENCE SECTIONS
INSTALLATION OF MACHINE	<p>When the machine is installed, perform the following:</p> <ol style="list-style-type: none"> <li>1. Check to see that each setting is as per standard setting made at the time of shipment.</li> <li>2. In the INPUT TEST mode, check such input devices as each SW, V.R., etc.</li> <li>3. In the OUTPUT TEST mode, check such output devices as lamps, motors, etc.</li> <li>4. In the SELF-TEST mode, check ICs on the IC Board.</li> </ol>	<p>8-2 F,G, 8-3 F 8-2 C, 8-3 B 8-3 C 8-2 B,J</p>
MEMORY	<p>Choose MEMORY TEST in the MENU mode to allow the MEMORY test to be performed. In this test, PROGRAM RAMs, ROMs, and ICs on the IC Board are checked.</p>	<p>8-2 B,J</p>
PERIODIC SERVICING	<p>Periodically perform the following:</p> <ol style="list-style-type: none"> <li>1. MEMORY TEST</li> <li>2. Ascertain each setting.</li> <li>3. In the INPUT TEST mode, test the CONTROL device</li> <li>4. In the OUTPUT TEST mode, check such output devices as lamps, motors, etc.</li> </ol>	<p>8-2 B,J 8-2 F,G, 8-3 F 8-2 C, 8-3 B 8-3 C</p>
CONTROL SYSTEM	<ol style="list-style-type: none"> <li>1. In the INPUT TEST mode, check such input devices as each SW, V.R., etc.</li> <li>2. Adjust or replace each SW and VR.</li> <li>3. If the problem can not be solved yet, check the CONTROL's moves.</li> </ol>	<p>8-2 C, 8-3 B 8-3 D,E, 9,10,11</p>
MONITOR	<p>In the MONITOR ADJUSTMENT mode, check to see if the adjustment is appropriately made.</p>	<p>8-2 E</p>
IC BOARD	<ol style="list-style-type: none"> <li>1. MEMORY TEST</li> <li>2. In the SOUND TEST mode, check the sound related ROMs.</li> </ol>	<p>8-2 B,J 8-2 D</p>
DATA CHECK	<p>Check such data as game play time and histogram to adjust the difficulty level, etc.</p>	<p>8-2 H, 8-3 G</p>

## 8 - 1 SWITCH UNIT AND COIN METER



Never touch places other than those specified. Touching places not specified can cause electric shock and short circuit hazards.



- Adjust to the optimum sound volume by considering the environmental requirements of the installation location.
- If the COIN METER and the game board are electrically disconnected, game play is not possible.

### SWITCH UNIT

Open the coin chute door, and the switch unit shown will appear.

The functioning of each SW is as follows:

The sound volumes of the front and rear speakers are adjusted as indicated by the illustration on the switch unit, at the factory before shipping. This adjustment aims to attain the best output balance between the front and rear speakers. Remember that carelessly changing this adjustment may cause the best balance to be lost.

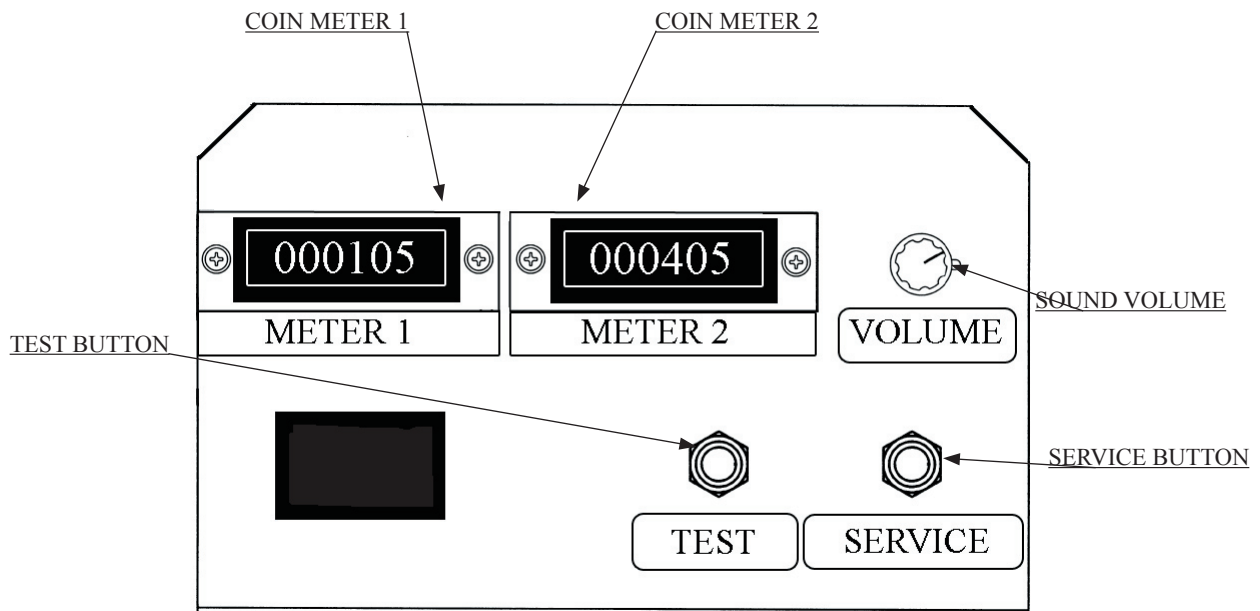

FIG. 8. 1 a SWITCH UNIT

- TEST BUTTON : For the handling of the test button, refer to the following pages.  
TEST  
SERVICE BUTTON : Gives credits without registering on the coin meter.  
SERVICE  
SOUND VOLUME : Adjusts the sound volume of the left and right speakers on the control  
FRONT SPEAKER panel

### COIN METER

Open the Cashbox Door by using the key to have the Coin Meter appear underneath the Cashbox.

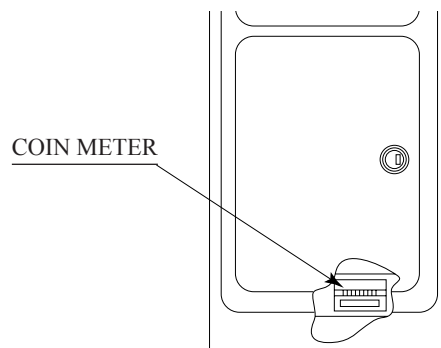

FIG. 8. 1 b COIN METER

## 8 - 2 SYSTEM TEST MODE

### A. SYSTEM TEST MODE MENU

Press TEST Button to enter the TEST MODE, and the following Menu screen will be displayed.

```

                SYSTEM MENU
XXXXXXXXXX VERSION

RAM TEST
JVS TEST
SOUND TEST
C.R.T. TEST
SYSTEM ASSIGNMENTS
COIN ASSIGNMENTS
BOOKKEEPING
BACKUP DATA CLEAR
ROMBD TEST
CLOCK SETTING
GAME TEST MODE
> EXIT

SELECT WITH SERVICE BUTTON
      AND
PRESS TEST BUTTON
```

- Press SERVICE Button to move the arrow (>) to the desired item and select with TEST Button.
- Bring the arrow to EXIT and press TEST Button to return to the GAME Mode.

### B. RAM TEST

This allows for checking the functioning of the RAM on the Game BD. In this test, IC's are checked in every row. During the test, "CHECKING" is displayed at the right-hand side of the screen. "BAD" is indicated for irregular RAMs, if any. Upon finishing the test, "PRESS TEST BUTTON TO EXIT" is displayed on the lower center of the monitor. Press TEST Button to return to the MENU screen.

```

                RAM TEST

IC15 IC16 IC17S IC18S   GOOD
IC22 IC23 IC24S IC25S   GOOD
IC28 IC29S                GOOD
IC41                      GOOD
IC42                      GOOD
IC44 IC45S IC46 IC47S   GOOD
IC91S IC92S                GOOD
IC98                      GOOD

      OPTIONAL SOUND BOARD:
IC2                      GOOD

OPTIONAL COMMUNICATION BOARD:
IC7 IC8 IC9 IC10        GOOD

PRESS TEST BUTTON TO EXIT
```

### C. JVS TEST

In this test, Functioning of the I/O Board connected to Game Board is displayed and INPUT TEST can be performed.

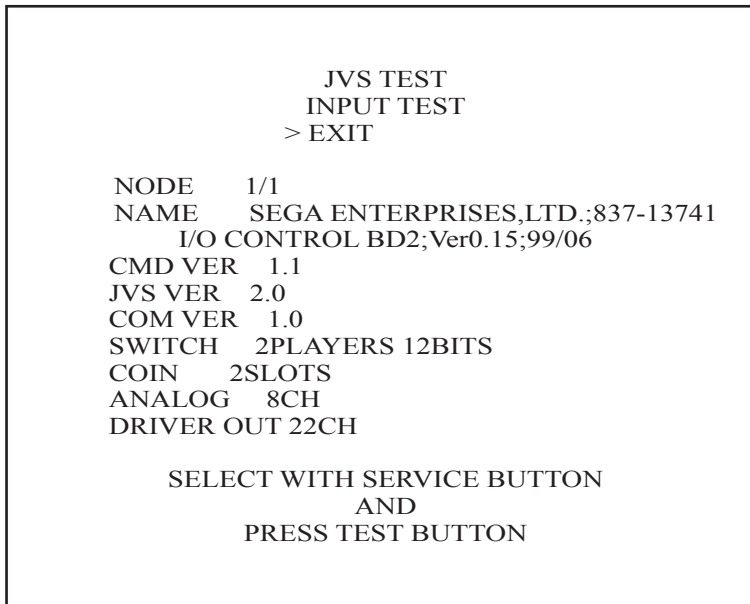

Execute EXIT to return to the MENU screen.

When INPUT TEST is selected and executed, the following screen appears.

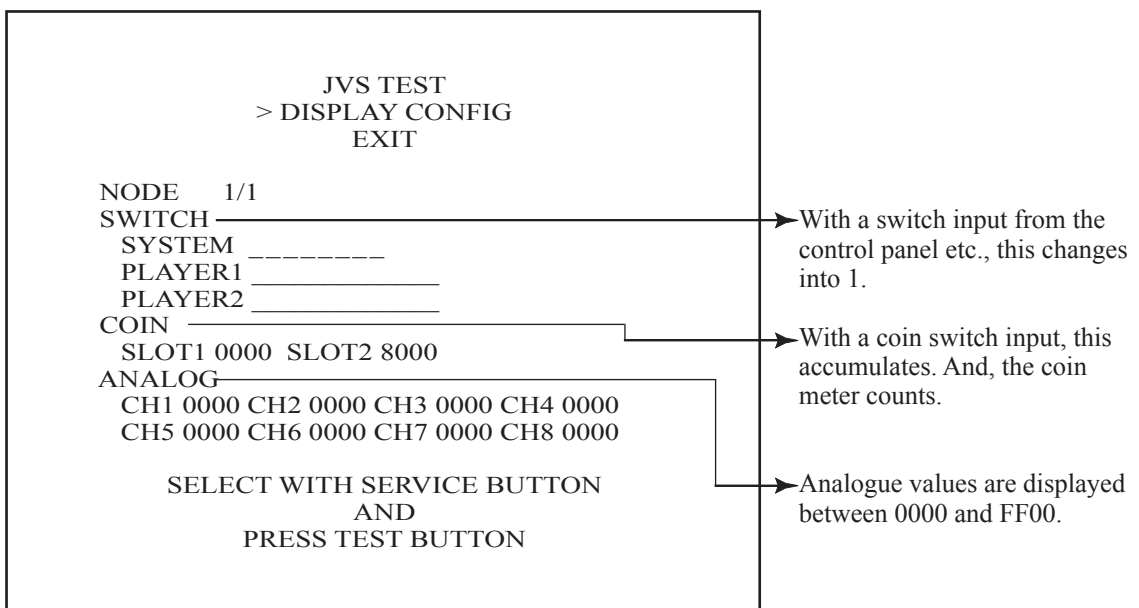

Execute EXIT to return to the MENU screen.

## D. SOUND TEST

This is a sound output test. Each speaker outputs the game's playing message in English.

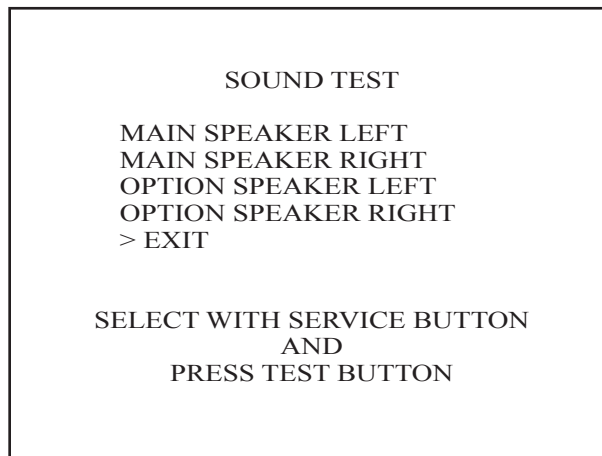

- MAIN SPEAKER LEFT : Output from the front left speaker
- MAIN SPEAKER RIGHT : Output from the front right speaker
- OPTION SPEAKER LEFT : Output from the rear left speaker
- OPTION SPEAKER RIGHT: Output from the rear right speaker

Front speakers are located on the control panel. Rear speakers are located on the seat's backrest.

Press the service button to move the > mark to a desired item (speaker), and press the test button. Make sure that the selected speaker outputs the playing message. The playing message heard indicates that the speaker and related wires are normal. Execute EXIT to return to the MENU screen.

## E. C.R.T. TEST

In this test, monitor adjustment can be performed. Periodically check to see if the monitor adjustment is appropriate in this test. This test consists of 2 screens. Use SERVICE Button to change the screen displayed. Press TEST Button to return to the MENU screen.

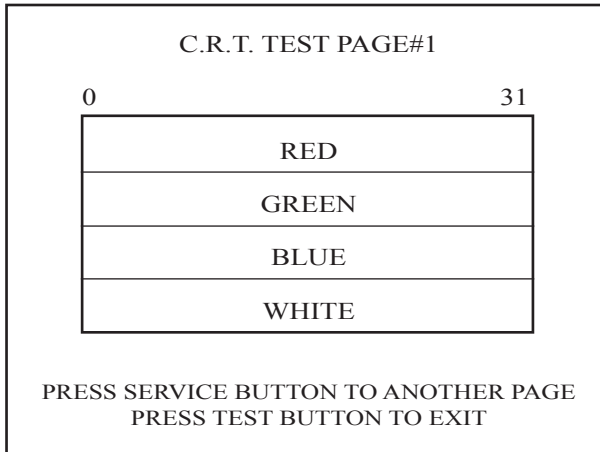

The first screen displays color bars. The color adjustment can be checked. Each of red, green, blue is the darkest at the left most end, and becomes brighter towards the right-hand end.

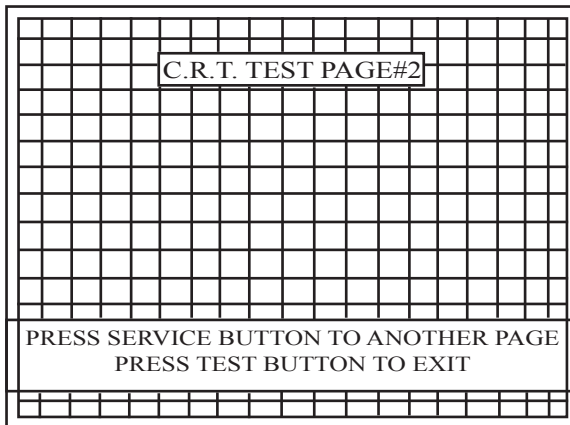

The second screen displays cross-hatches. In this page, monitor size and deviation can be checked.

## F. SYSTEM ASSIGNMENTS



Set the CABINET TYPE and MONITOR TYPE to a correct value according to the cabinet you use. If you fail to observe this, an error message appears when connecting the power and when exiting from a test mode; and eventually you cannot play the game.

Performs setting for the whole system. Set each item in accordance with the cabinet. Use the items except ADVERTISE SOUND and COMMUNICATION MODE as they are at the time of shipment. To change setting, bring the arrow (>) to the desired item with the SERVICE button and press the TEST button.

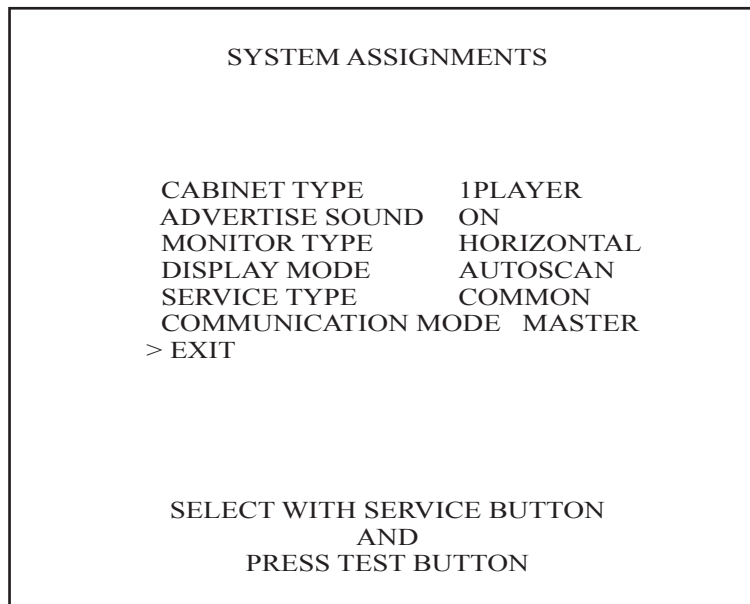

- CABINET TYPE (1PLAYER ~ 8PLAYERS) :Always set to 1PLAYER.
- ADVERTISE SOUND (ON, OFF) :Set to ON or OFF (that enables to output or not an advertise sound from the speakers).
- MONITOR TYPE (HORIZONTAL, VERTICAL) :Always set to HORIZONTAL.
- DISPLAY MODE (AUTOSCAN, 31KHz, 24KHz):Always set to AUTOSCAN.
- SERVICE TYPE (COMMON, INDIVIDUAL) :Always set to COMMON.
- COMMUNICATION MODE (MASTER, SLAVE, RELAY, NO LINK):

Select from among MASTER, SLAVE, NO LINK, and RELAY.

When performing setting for communication play, be careful of the following points.

MASTER :Set only one of the linked machine to MASTER for communication play.

SLAVE :Set the other linked machines to SLAVE for communication play.

RELAY :Set to RELAY when you want to use the machine as a monitor showing the communication play.

NO LINK :Set to NO LINK when you operate the machine alone.



## G. COIN ASSIGNMENTS

In this mode, the setting of incremental credit increase as against coin insertion can be changed.

This test consists of 3 screens, and the following is the first screen.

The setting done in the first screen will be stored when exited.

COIN ASSIGNMENTS	
COIN CHUTE TYPE	COMMON
COIN/CREDIT SETTING	#1
COIN CHUTE	#1
1COIN 1CREDIT	
COIN CHUTE	#2
1COIN 1CREDIT	
MANUAL SETTING	
SEQUENCE SETTING	
> EXIT	
SELECT WITH SERVICE BUTTON AND PRESS TEST BUTTON	

- COIN CHUTE TYPE sets whether Coin Chute is used in common by all players or separately allocated to each player in case 2 or more Coin Chutes are incorporated.  
COMMON: This setting is for common use by plural players.  
INDIVIDUAL: As each player uses an independent coin chute, setting to INDIVIDUAL causes COIN CHUTE #2 to be disappeared.
  
- COIN/CREDIT SETTING is set when using one of the existing 26 settings or FREE PLAY. The selected coin rates in the COIN/CREDIT SETTING are displayed below COIN CHUTE #1 and COIN CHUTE #2. If you wish to set a coin rate rather than to select from the existing setting, select MANUAL SETTING. The display next to COIN/CREDIT SETTING indicates "MANUAL", not "#n" in this case.

## ○ MANUAL SETTING

When MANUAL SETTING is selected in the first screen, the following second screen appears.

COIN ASSIGNMENTS MANUAL SETTING	
COIN TO CREDIT	1
BONUS ADDER	0
COIN CHUTE #1 MULTIPLIER	
1 COINCOUNT AS	1COIN
COIN	1 2 3 4 5 6 7 8 9
CREDIT	1 2 3 4 5 6 7 8 9
COIN CHUTE #2 MULTIPLIER	
1 COINCOUNT AS	1COIN
COIN	1 2 3 4 5 6 7 8 9
CREDIT	1 2 3 4 5 6 7 8 9
SEQUENCE SETTING	
> EXIT	
SELECT WITH SERVICE BUTTON AND PRESS TEST BUTTON	

- COIN TO CREDIT determines how many coins are needed for one credit. (1 ~ 9)
- BONUS ADDER determines how many coins should be inserted to obtain one SERVICE COIN.
- COIN CHUTE #1 MULTIPLIER, COIN CHUTE #2 MULTIPLIER sets how many tokens one Coin represents inserted in each COIN CHUTE.

### SETTING EXAMPLE 1)

Setting of 2 COINS 1 CREDIT, set to:  
COIN TO CREDIT :2  
BONUS ADDER :0  
COIN CHUTE #1 MULTIPLIER :1

### SETTING EXAMPLE 2)

Setting of 5 COINS 6 CREDITS (5 COINS 1 BONUS), set to  
COIN TO CREDIT :1  
BONUS ADDER :5  
COIN CHUTE #1 MULTIPLIER :1

When exiting from MANUAL SETTING, if the identical coin rate is in the existing COIN/CREDIT SETTING, such existing mode other than what is set in the MANUAL SETTING is confirmed.

TABLE 1 COIN/CREDIT SETTING

NAME OF SETTING	FUNCTIONING OF COIN CHUTE #1		FUNCTIONING OF COIN CHUTE #2	
SETTING #1	1 COIN	1 CREDIT	1 COIN	1 CREDIT
SETTING #2	1 COIN	2 CREDITS	1 COIN	1 CREDIT
SETTING #3	1 COIN	3 CREDITS	1 COIN	1 CREDIT
SETTING #4	1 COIN	4 CREDITS	1 COIN	1 CREDIT
SETTING #5	1 COIN	5 CREDITS	1 COIN	1 CREDIT
SETTING #6	1 COIN	2 CREDITS	1 COIN	2 CREDITS
SETTING #7	1 COIN	5 CREDITS	1 COIN	2 CREDITS
SETTING #8	1 COIN	3 CREDITS	1 COIN	3 CREDITS
SETTING #9	1 COIN	4 CREDITS	1 COIN	4 CREDITS
SETTING #10	1 COIN	5 CREDITS	1 COIN	5 CREDITS
SETTING #11	1 COIN	6 CREDITS	1 COIN	6 CREDITS
SETTING #12	2 COINS	1 CREDIT	2 COINS	1 CREDIT
SETTING #13	1 COIN	1 CREDIT	2 COINS	1 CREDIT
SETTING #14	1 COIN	2 CREDITS	2 COINS	1 CREDIT
SETTING #15	1 COIN	1 CREDIT	1 COIN	1 CREDIT
	2 COINS	3 CREDITS	2 COINS	3 CREDITS
SETTING #16	1 COIN	3 CREDITS	1 COIN	1 CREDIT
			2 COINS	3 CREDITS
SETTING #17	3 COINS	1 CREDIT	3 COINS	1 CREDIT
SETTING #18	4 COINS	1 CREDIT	4 COINS	1 CREDIT
SETTING #19	1 COIN	1 CREDIT	1 COIN	1 CREDIT
	2 COINS	2 CREDITS	2 COINS	2 CREDITS
	3 COINS	3 CREDITS	3 COINS	3 CREDITS
	4 COINS	5 CREDITS	4 COINS	5 CREDITS
SETTING #20	1 COIN	5 CREDITS	1 COIN	1 CREDIT
			2 COINS	2 CREDITS
			3 COINS	3 CREDITS
			4 COINS	5 CREDITS
SETTING #21	5 COINS	1 CREDIT	5 COINS	1 CREDIT
SETTING #22	1 COIN	2 CREDITS	3 COINS	1 CREDIT
			5 COINS	2 CREDITS
SETTING #23	2 COINS	1 CREDIT	2 COINS	1 CREDIT
	4 COINS	2 CREDITS	4 COINS	2 CREDITS
	5 COINS	3 CREDITS	5 COINS	3 CREDITS
SETTING #24	1 COIN	3 CREDITS	2 COINS	1 CREDIT
			4 COINS	2 CREDITS
			5 COINS	3 CREDITS
SETTING #25	1 COIN	1 CREDIT	1 COIN	1 CREDIT
	2 COINS	2 CREDITS	2 COINS	2 CREDITS
	3 COINS	3 CREDITS	3 COINS	3 CREDITS
	4 COINS	4 CREDITS	4 COINS	4 CREDITS
	5 COINS	6 CREDITS	5 COINS	6 CREDITS
SETTING #26	1 COIN	6 CREDITS	1 COIN	1 CREDIT
			2 COINS	2 CREDITS
			3 COINS	3 CREDITS
			4 COINS	4 CREDITS
			5 COINS	6 CREDITS
SETTING #27	FREE PLAY		FREE PLAY	

Table 2: COIN/CREDIT SETTING (COIN CHUTE INDIVIDUAL TYPE)

NAME OF SETTING	EACH SEAT'S COIN CHUTE	NAME OF SETTING	EACH SEAT'S COIN CHUTE
SETTING #1	1 COIN 1 CREDIT	SETTING #21	5 COINS 1 CREDIT
SETTING #2	1 COIN 2 CREDITS	SETTING #23	2 COINS 1 CREDIT
SETTING #3	1 COIN 3 CREDITS		4 COINS 2 CREDITS
SETTING #4	1 COIN 4 CREDITS		5 COINS 3 CREDITS
SETTING #5	1 COIN 5 CREDITS		SETTING #25
SETTING #11	1 COIN 6 CREDITS	2 COINS 2 CREDITS	
SETTING #12	2 COINS 1 CREDIT	3 COINS 3 CREDITS	
SETTING #15	1 COIN 1 CREDIT	4 COINS 4 CREDITS	
	2 COINS 3 CREDITS	5 COINS 6 CREDITS	
SETTING #17	3 COINS 1 CREDIT	SETTING #27	FREE PLAY
SETTING #18	4 COINS 1 CREDIT		
SETTING #19	1 COIN 1 CREDIT		
	2 COINS 2 CREDITS		
	3 COINS 3 CREDITS		
	4 COINS 5 CREDITS		

Table 3: MANUAL SETTING

COIN TO CREDIT	1 COIN 1 CREDIT
	2 COINS 1 CREDIT
	3 COINS 1 CREDIT
	4 COINS 1 CREDIT
	5 COINS 1 CREDIT
	6 COINS 1 CREDIT
	7 COINS 1 CREDIT
	8 COINS 1 CREDIT
	9 COINS 1 CREDIT
BONUS ADDER	NO BONUS ADDER
	2 COINS GIVE 1 EXTRA COIN
	3 COINS GIVE 1 EXTRA COIN
	4 COINS GIVE 1 EXTRA COIN
	5 COINS GIVE 1 EXTRA COIN
	6 COINS GIVE 1 EXTRA COIN
	7 COINS GIVE 1 EXTRA COIN
	8 COINS GIVE 1 EXTRA COIN
	9 COINS GIVE 1 EXTRA COIN
COIN CHUTE (# 1 / # 2) MULTIPLIER	1 COIN COUNTS AS 1 COIN
	1 COIN COUNTS AS 2 COINS
	1 COIN COUNTS AS 3 COINS
	1 COIN COUNTS AS 4 COINS
	1 COIN COUNTS AS 5 COINS
	1 COIN COUNTS AS 6 COINS
	1 COIN COUNTS AS 7 COINS
	1 COIN COUNTS AS 8 COINS
	1 COIN COUNTS AS 9 COINS

## ○ SEQUENCE SETTING

When SEQUENCE SETTING is selected in either first or second screen, the SEQUENCE SETTING Mode (the third screen) appears.

In this mode, number of credits required for starting game can be set.

```
COIN ASSIGNMENTS
SEQUENCE SETTING

SEQUENCE1          *CREDIT
SEQUENCE2          *CREDIT
SEQUENCE3          *CREDIT
SEQUENCE4          *CREDIT
SEQUENCE5          *CREDIT
SEQUENCE6          *CREDIT
SEQUENCE7          *CREDIT
SEQUENCE8          *CREDIT
> EXIT

[ XXXXXXXXXXXXXXXXXXXXXXXXXX ]
[ SEGA ENTERPRISES,LTD. ]
DESCRIPTION OF SEQUENCE
SEQ1 CREDIT TO 1 PLAYER START
SEQ2 NOT USED
SEQ3 NOT USED
SEQ4 NOT USED
SEQ5 NOT USED
SEQ6 NOT USED
SEQ7 NOT USED
SEQ8 NOT USED

SELECT WITH SERVICE BUTTON
AND
PRESS TEST BUTTON
```

SEQUENCE1 : Credit number enough to start the game

Each sequence can be set between 1 ~ 5.

SEQUENCE 2 to 8 are not used. On the screen, however, the credit number is changeable.

Select EXIT to return to the first screen.

## H. BOOKKEEPING

This allows such data as operating time/No. of coins inserted/ No. of credits to be checked, etc.

This test consists of 2 screens. Pressing SERVICE Button causes screen to be changed. Press TEST Button to return to the MENU screen.

On the first screen, such data as total time, coin, and credit are displayed.

```
BOOKKEEPING PAGE#1

TOTAL TIME      55H27M13S
COIN1   16      SERVICE   5
COIN2   4        SERVICE2  0
CREDIT  10

TOTAL COIN20
COIN CREDIT      10
SERVICE CREDIT  5
TOTAL CREDIT1    5

PRESS SERVICE BUTTON TO ANOTHER PAGE
PRESS TEST BUTTON TO EXIT
```

Total Time is displayed as "X X H X X M X X S" and no date will be displayed after exceeding 24 hours.

On the second screen, each sequence displays the frequency of functioning.

```
BOOKKEEPING PAGE#2

PLAYER1
SEQ1      1
SEQ2      0
SEQ3      1
SEQ4      0
SEQ5      0
SEQ6      0
SEQ7      0
SEQ8      0

PRESS SERVICE BUTTON TO ANOTHER PAGE
PRESS TEST BUTTON TO EXIT
```

## I. BACKUP RAM CLEAR

This enables you to clear the BOOKKEEPING data (coin- and credit-related data and TOTAL TIME data) in the SYSTEM MENU screen.

NOTE: The same screen appears also in the GAME TEST MENU screen to clear the operating data.

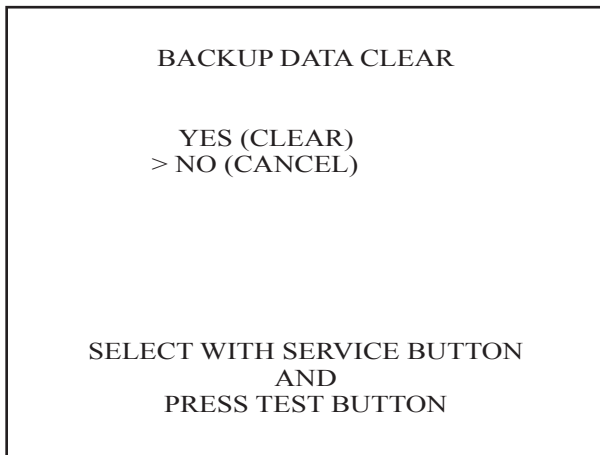

Press the service button to move the > mark to YES (CLEAR) item, and press the test button. When the system completes clearing, a 'COMPLETED' message appears on the screen. Press the test button again to return to the SYSTEM MENU screen.

Press the service button to move the > mark to NO (CANCEL) item, and press the test button. The system does not execute clearing, but returns to the SYSTEM MENU screen.

## J. ROMBD TEST

This screen enables to check the ROM on the ROM board. When the system completes checking successfully or unsuccessfully, respectively 'GOOD' or 'BAD' message appears on the screen. For the program ROM (IC 35 and IC36), 'GOOD' or 'BAD' message does not appear.

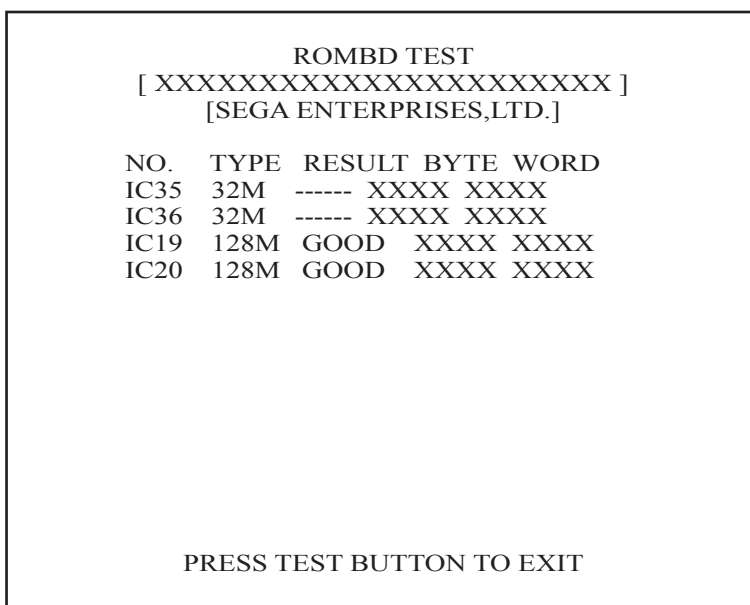

Press TEST Button to return to MENU mode.

## K. CLOCK SETTING

The ranking data appears during advertising. It is automatically updated weekly; therefore correctly set the clock in the CLOCK SETTING screen.

YEAR, MONTH, DAY, HOUR, and MINUTE are set for SEGA HIKARU BD.

Select the desired item with SERVICE Button and press TEST Button to increase the value. Bring the arrow to EXIT and press TEST Button to return to MENU Mode.

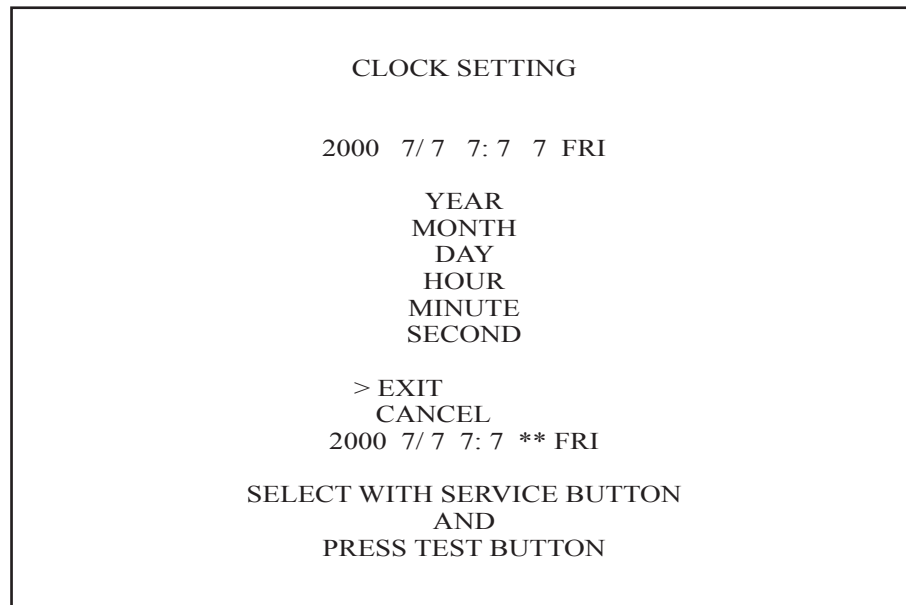

## L. GAME TEST MODE

Enters the TEST Mode of the game connected to SEGA HIKARU BD. The TEST Mode includes INPUT Test, GAME ASSIGNMENTS such as game difficulty, etc. Refer to 9-3 for details.



## 8 - 3 GAME TEST MODE

### A. GAME MENU

Press the service button to move the > mark to GAME TEST MODE item, and press the test button. Then the following GAME TEST MODE screen appears.

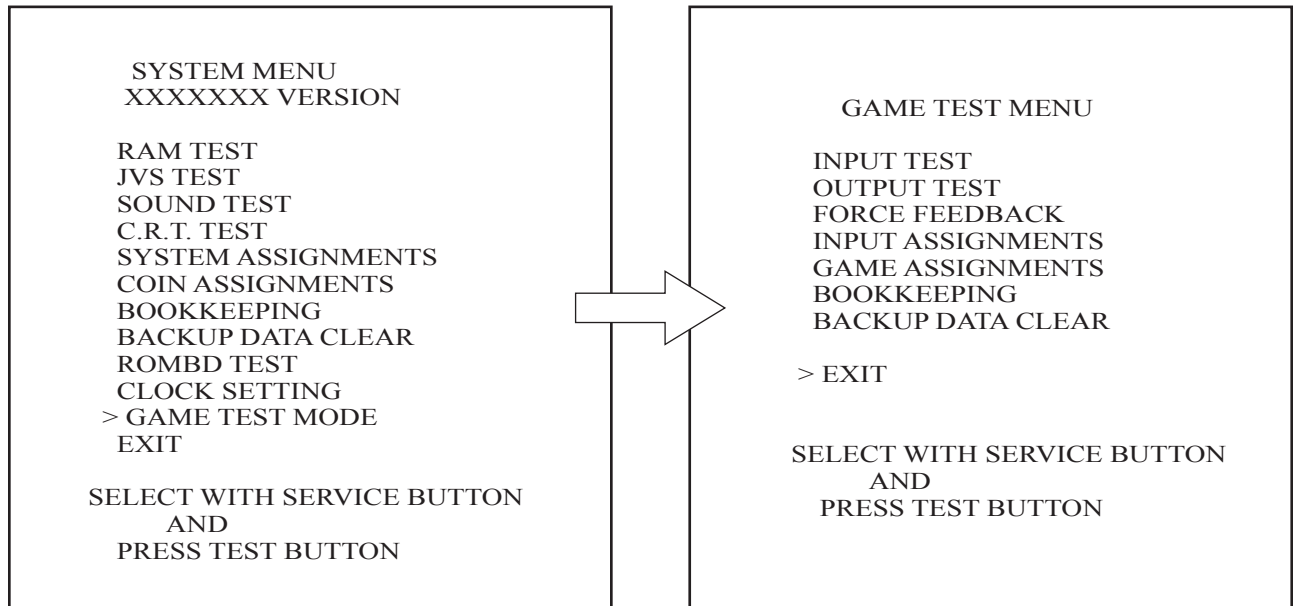

Press the service button to move the > mark to any desired item, and press the test button. Then the selected item's screen appears. In the screen use the service button and the test button similarly to in the SYSTEM MENU screens.

After testing, select the EXIT and press the test button. The SYSTEM MENU screen reappears. Again select the EXIT and press the test button. The SYSTEM MENU screen disappears, and a playing mode screen appears.

## B. INPUT TEST

Press the service button to select the INPUT TEST item in the GAME TEST MENU screen, and press the test button. The following INPUT TEST screen appears.

Periodically test the input devices by using the screen.

INPUT TEST	
STEERING WHEEL	XXX
GAS PEDAL	XXX
BRAKE PEDAL	XXX
GEAR POSITION	ON
START BUTTON	OFF
VIEW CHANGE BUTTON	OFF
SERVICE SWITCH	OFF
TEST SWITCH	OFF
PRESS TEST AND SERVICE BUTTON TO EXIT	

- Each of STEERING WHEEL, GAS PEDAL, and BRAKE PEDAL indicates an analog value. Make sure that the value can smoothly change as you operate the input device. If not smoothly, readjust the volume or replace it with a new one. (See Chapter 10 and 12.)
- GEAR POSITION indicates N, 1,2,3, or 4. Make sure that the value can change as you operate the 4-speed shifter. If not, replace the switch with a new one. (See Chapter 11.)
- Make sure that each of the rest of the input devices can change its indication from OFF to ON as you operate the device.
- After testing, press the test button and the service button simultaneously. The GAME TEST MENU screen reappears.

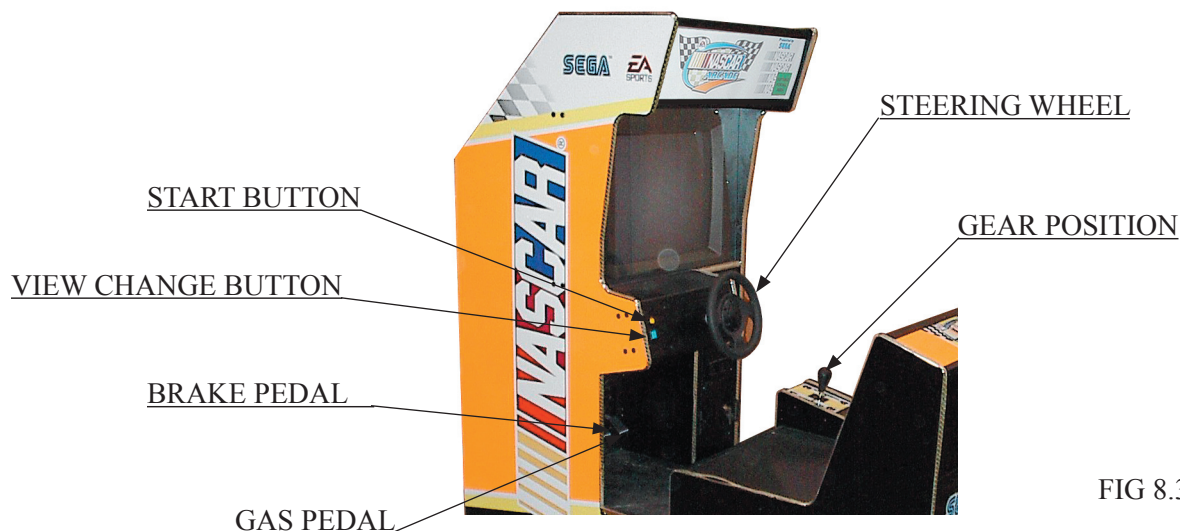
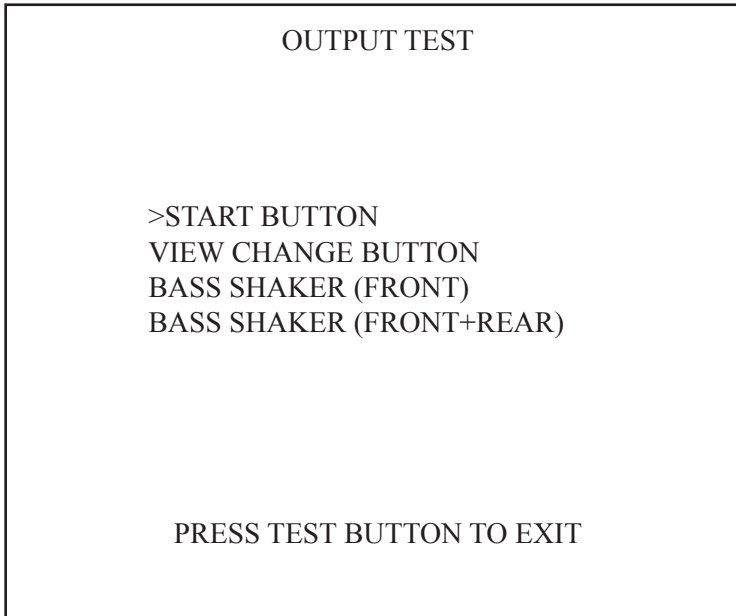

FIG 8.3 b

### C. OUTPUT TEST

Press the service button to select the OUTPUT TEST item in the GAME TEST MENU screen, and press the test button. The following OUTPUT TEST screen appears to test the output devices.

Periodically test the output devices ( the lights integrated with the START and VIEW CHANGE BUTTONS and BASE SHAKER) by using the screen.



Item is automatically changed or selected in turn. Make sure that the corresponding output device can normally operate (that is, the light comes on or the BASE SHAKER vibrates). After testing, press the test button. The GAME TEST MENU screen reappears.

D. FORCE FEEDBACK

DOES NOT APPLY TO THIS MODEL!

## E. INPUT ASSIGNMENTS

Press the service button to select the INPUT ASSIGNMENTS item in the GAME TEST MENU screen, and press the test button. The following INPUT ASSIGNMENTS screen appears to select the input device.

INPUT ASSIGNMENTS	
STEERING	0
(DEFAULT = 0)	
GAS PEDAL	0
(DEFAULT = 0)	
BRAKE PEDAL	0
(DEFAULT = 0)	
DEFAULT SETTING	
>EXIT	
SELECT WITH SERVICE BUTTON AND PRESS TEST BUTTON	

Press the service button to move the > mark to a targeted input device to select, and press the test button. Then the assignments screen of the selected input device appears.

Selecting the DEFAULT SETTING recovers to the standard factory settings.

After testing, select the EXIT and press the test button. The GAME TEST MENU screen reappears.

### Ea. STEER ASSIGNMENTS

This screen enables you to set the volume value of the steering wheel (handle). In other words, this screen sets the volume value of the steering wheel's center position (for a straight ahead direction). Reset the volume value on this screen when the operability of the steering wheel is undesirable. Also newly set the volume value on this screen whenever you have adjusted or replaced the volume.

STEER ASSIGNMENTS	
(MIN - 40 : MAX 40 : DEFAULT 0)	
STEERING = 10	
0	
^	
CENTER	
RIGHT	
LEFT	
>EXIT	
SELECT WITH SERVICE BUTTON AND PRESS TEST BUTTON	

First fix the steering wheel to a center position (for a straight ahead direction). Check '0' for a position on the screen. If it is not on the (mark above the CENTER, press the service button to move the >mark to the RIGHT or LEFT, and press the test button so that the '0' is positioned just on the >mark).

After testing, select the EXIT and press the test button. The INPUT ASSIGNMENTS screen reappears.

## Eb. GAS ASSIGNMENTS

This screen enables you to set the volume value of the gas pedal (accelerator). The MIN indicates the volume value when the pedal is not stepped on and the MAX when stepped on.

Reset the volume value on this screen when the operability of the gas pedal is undesirable. Also newly set the volume value on this screen whenever you have adjusted or replaced the volume.

```
GAS ASSIGNMENTS
(MIN - 40 : MAX 40 : DEFAULT 0)
  GAS = 10
      0      0
      ^      ^
      MIN    MAX
UP
DOWN
>EXIT
SELECT WITH SERVICE BUTTON
      AND
PRESS TEST BUTTON
```

Check the '0' for a position on the screen. If it is not on the ^ marks above the MIN and MAX, press the service button to move the ^ mark UP or DOWN, and press the test button so that the '0' is positioned just on the ^ marks.

After testing, select the EXIT and press the test button. The INPUT ASSIGNMENTS screen reappears.

## Ec. BRAKE ASSIGNMENTS

This screen enables you to set the volume value of the brake pedal. The MIN indicates the volume value when the pedal is not stepped on and the MAX when stepped on.

Reset the volume value on this screen when the operability of the brake pedal is undesirable. Also newly set the volume value on this screen whenever you have adjusted or replaced the volume.

```
BRAKE ASSIGNMENTS
(MIN - 40 : MAX 40 : DEFAULT 0)
  GAS = 10
      0      0
      ^      ^
      MIN    MAX
UP
DOWN
>EXIT
SELECT WITH SERVICE BUTTON
      AND
PRESS TEST BUTTON
```

Check the '0' for a position on the screen. If it is not on the ^ marks above the MIN and MAX, press the service button to move the ^ mark UP or DOWN, and press the test button so that the '0' is positioned just on the ^ marks.

After testing, select the EXIT and press the test button. The INPUT ASSIGNMENTS screen reappears.

## F. GAME ASSIGNMENTS

Press the service button to select the GAME ASSIGNMENTS item in the GAME TEST MENU screen, and press the test button. The following GAME ASSIGNMENTS screen appears to set the game mode, game difficulty, etc.

Note that the GAME MODE and GAME DIFFICULTY items are displayed only when you have set the COMMUNICATION MODE to MASTER or NO LINK (See Chapter 9-2F).

GAME ASSIGNMENTS	
GAME MODE (SINGLE)	NORMAL
GAME MODE (NETWORK)	NORMAL
GAME DIFFICULTY	NORMAL
DEFAULT VIEW	DRIVER
SPEED DISPLAY	KM/H
SEAT NUMBER	1
>EXIT	
SELECT WITH SERVICE BUTTON AND PRESS TEST BUTTON	

Press the service button to move the > mark to a targeted item to select. Then press the test button to change the setting on the right.

After setting, select the EXIT and press the test button. The GAME TEST MENU screen reappears.

### • GAME MODE (SINGLE)

Set the GAME MODE to SINGLE when you play alone. There are two settings available: NORMAL and SPECIAL. The latter features moving from course to course in the race.

**NORMAL:** This is a standard setting. Selection of the extra course is explained only after you have totally played 1,000 times and at the end of each advanced course game.

Course	No. of Cycling
Beginner Talladega	4
Intermediated Richmond	8
Advanced Watkins Glen	3
Extra	10

**SPECIAL:** You select any course to start and then move from course to course as indicated below. Naturally it takes a long time to clear all the games.

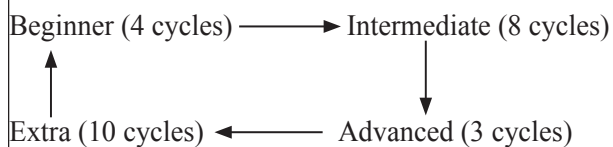

### • GAME MODE (NETWORK)

Set the GAME MODE to the NETWORK when you play a communication play. There are two settings available: NORMAL and SPECIAL. The latter features more cycling than the former.

**NORMAL:** This is a standard setting.

Course	No. of Cycling
Beginner Talladega	4
Intermediated Richmond	8
Advanced Watkins Glen	3
Extra	10

**SPECIAL:** The SPECIAL features more cycling than NORMAL. Naturally it takes a long time to clear all the games. It is, therefore, employed in an event.

Course	No. of Cycling
Beginner Talladega	4
Intermediated Richmond	8
Advanced Watkins Glen	3
Extra	10

- GAME DIFFICULTY : Sets the game's difficulty level. You can set it to VERY EASY, EASY, NORMAL, HARD, OR VERY HARD.
- DEFAULT VIEW : Sets the viewpoint when a game is started. you can set it to DRIVER or REAR.
- SPEED DISPLAY : Sets the unit used to display the speed. You can set it to KM/H or MPH.
- SEAT NUMBER : Sets the number of the cabinets interconnected for a communication play. Arrange them; and facing the screen set their SEAT NUMBER to 1,2,3,.....from left to right. If you have set the COMMUNICATION MODE to the RELAY (a live relay monitor), set the SEAT NUMBER to the NO DEFINED.



## G. BOOKKEEPING

Press the service button to select the Bookkeeping item in the GAME TEST MENU screen, and press the test button. The following BOOKKEEPING screens (1/2 & 2/2) appear to display the operation data. Press the service button to migrate between the 1/2 and 2/2 screens. After setting, select the EXIT and press the test button. The GAME TEST MENU screen reappears.

BOOKKEEPING 1/2			
CABINET TYPE			XXXX
NUMBER OF GAMES			0
PLAY TIME			0D 0H 0M 0S
AVERAGE PLAY TIME			0M 0S
LONGEST PLAY TIME			0M 0S
SHORTEST PLAY TIME			0M 0S
PLAY TIME HISTROGRAM			
0M 0S ~ 1M59S	----		0
2M 0S ~ 2M29S	----		0
2M 30S ~ 2M59S	----		0
3M 0S ~ 3M29S	----		0
3M 30S ~ 3M59S	----		0
4M 0S ~ 4M29S	----		0
4M 30S ~ 4M59S	----		0
5M 0S ~ 5M29S	----		0
5M 30S ~ 5M59S	----		0
6M 0S ~ 6M29S	----		0
OVER 6M30S	----		0
PRESS SERVICE BUTTON TO ANOTHER PAGE			
PRESS TEST BUTTON TO EXIT			

- CABINET TYPE : Displays the type of the cabinet used. It is automatically detected by the system.
- NUMBER OF GAME : Displays the total number of the games played.
- PLAY TIME : Displays the total operating hours.
- PLAY TIME HISTOGRAM : Displays the number of the games per playing period.

BOOKKEEPING 2/2

DRIVER SELECT

Steve Park	0
Rusty Wallace	0
Dale Earnhardt	0
Bobby Hamilton	0
Terry Labonte	0
Mark Martin	0
Michael Waltrip	0

COURSE SELECT

Talladega	0
Richmond	
Watkins Glen	0

TRANSMISSION SELECT

AUTOMATIC	0
MANUAL	0

PRESS SERVICE BUTTON TO ANOTHER PAGE  
PRESS TEST BUTTON TO EXIT

- DRIVER SELECT : Displays the number of selection times for the most frequently selected 7 players.
- COURSE SELECT : Displays the number of selection times by course.
- TRANSMISSION SELECT : Displays the number of selection times by transmission type.

## H. BACKUP DATA CLEAR

Press the service button to select the BACKUP DATA CLEAR item in the GAME TEST MENU screen, and press the test button. This screen enables to clear the BOOKKEEPING data and the ranking data.

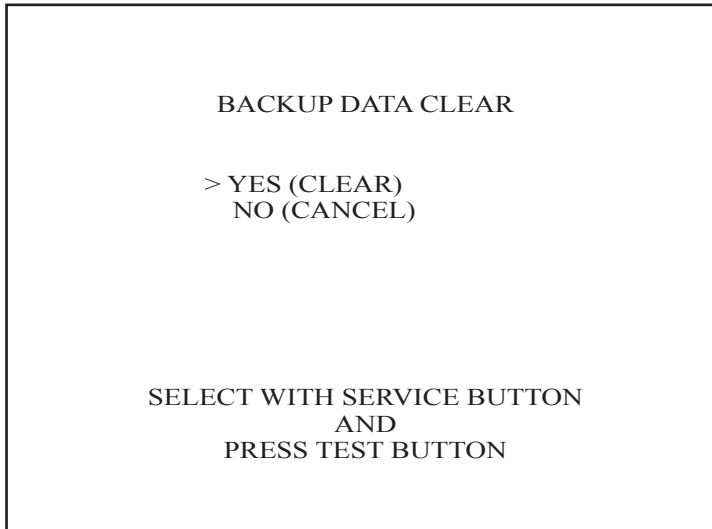

Press the service button to move the > mark to YES (CLEAR) item, and press the test button. When the system completes clearing, a 'COMPLETED' message appears on the screen. Press the test button again to return to the GAME TEST MENU screen.

Press the service button to move the > mark to NO (CANCEL) item, and press the test button. The system does not execute clearing, but returns to the GAME TEST MENU screen.

## 9. CONTROL PANEL



- Before starting to work, ensure that the Power SW is OFF. Failure to observe this can cause electric shock or short circuit.
- Use care so as not to damage wirings. Damaged wiring can cause electric shock or short circuit.
- Do not touch undesignated places. Touching places not designated can cause electric shock or short circuit.
- This work should be performed by the Location's Maintenance Man or Serviceman. Performing work by non-technical personnel can cause electric shock hazard.
- Do not insert hand into the mechanism so as not to cause hand and fingers pinched in. Failure to observe this can cause a serious injury such as a fracture.
- When performing work such as parts replacement other than those specified in this manual, be sure to contact where you purchased the product from and confirm the work procedures and obtain precautions prior to performing work. Inappropriate parts replacement and/or installing with erroneous adjustment can cause an overload or the parts to come into contact, resulting in an electric shock, a short circuit, and a fire.

### 9 - 1 ADJUSTING OR REPLACING THE V.R.

In cases the Steering operability is poor and the adjustment of VOLUME SETTING in the TEST mode is ineffective, the causes may be the Volume Gear's mesh failure and or Volume malfunctioning. By using the following procedure, adjust Volume gear mesh, or replace the Volume. In this product, when the Steering Wheel is moved fully left/right, if the Volume shaft is rotating within the movable range, the Volume is not feared to be damaged. Secure the Volume in the manner the Volume shaft is oriented as shown and the gears are appropriately engaged when the steering wheel is in the centering position allowing the car to go straight forward.

#### ADJUSTING THE VOLUME

- ① Turn off power.
- ② Remove the 6 Truss head screws and detach the Front Lid from the main cabinet.

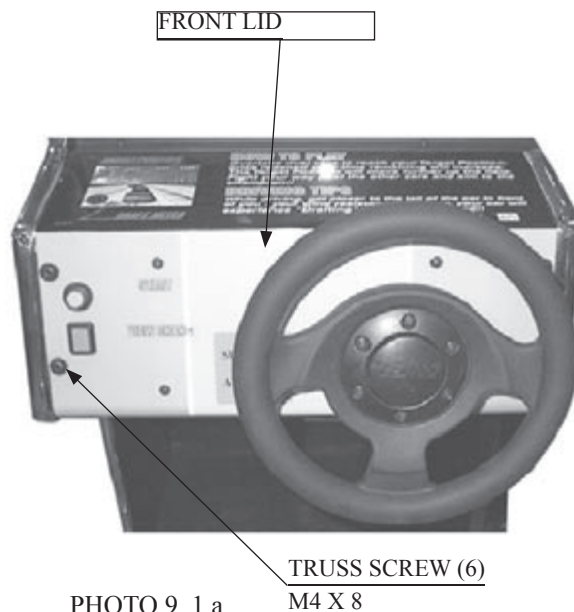

- ③ The V.R. is on the VR BASE. Loosen the 2 screws which secure the VR BASE and adjust the angle and appropriateness of gear mesh by moving the VR BASE.
- ④ Adjust to an appropriate mesh by securing the Steering Wheel in the direction allowing the car to advance straight forward and ensuring the "D" CUT FACE of the Volume shaft is oriented as shown.
- ⑤ Tighten the 2 screws to secure the VR BASE.

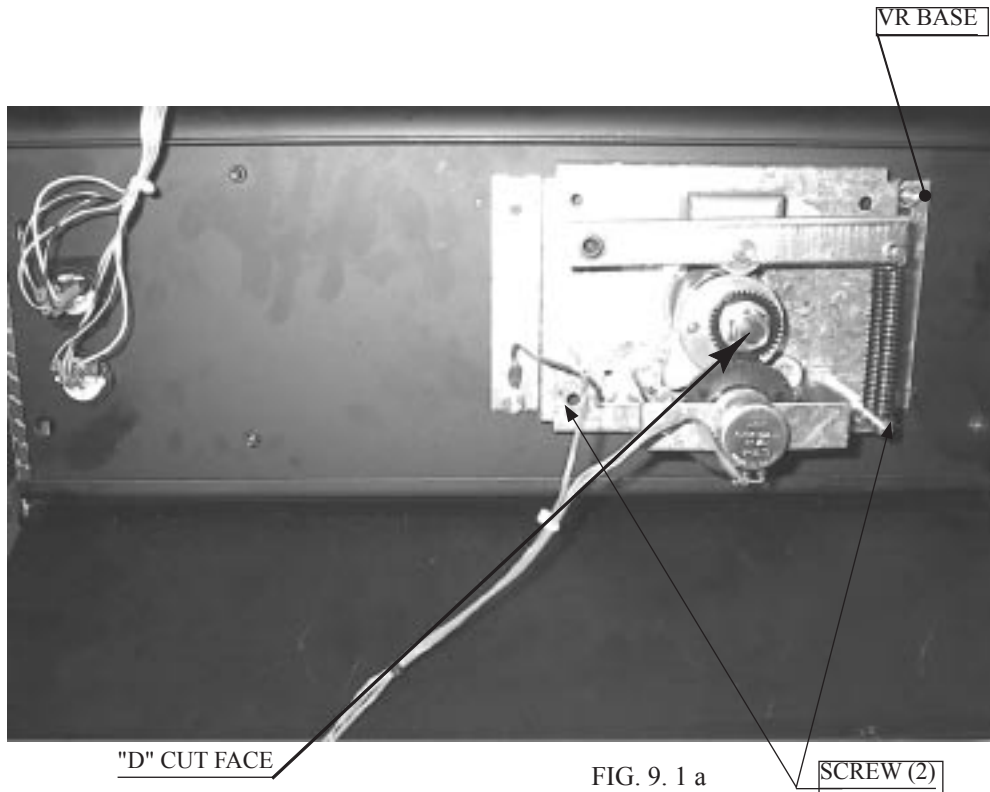

FIG. 9. 1 a

- ⑥ Turn on power.
- ⑦ Set the Center Value of the Volume in the TEST mode.
- ⑧ In the TEST mode, check to see if the Volume Value varies smoothly in accordance with the steering wheel operation.

# WHEEL STEERING - HAPP CONTROLS part no. 50-2838-00-XV

Tom Happ  
tom.happ@happcontrols.com  
Happ Controls  
106 Garlish Drive  
Elk Grove, IL. 60007  
Ph. 847-593-6161 ext. 107  
Fx. 847-956-2091

Visit our website <http://www.happcontrols.com>

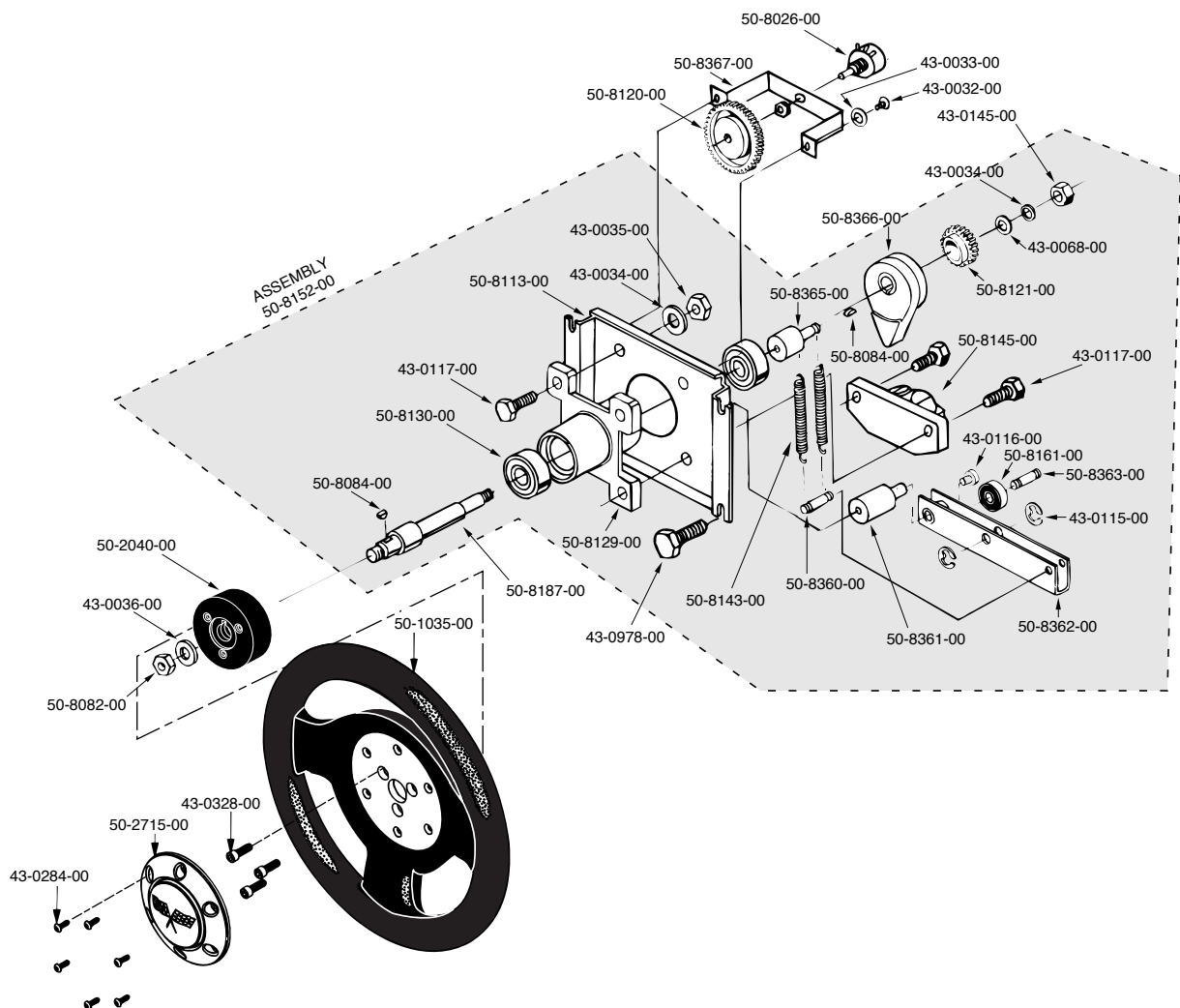

## 9 - 2 GREASING



Be sure to use the designated grease. Using undesignated grease can cause parts damage.  
Do not apply greasing to undesignated places. Failure to observe this can cause malfunctioning or quality deterioration of parts.

Apply greasing to gear mesh portions once every 3 months. Use GREASE MATE (SEGA PART NO. 090-0066).

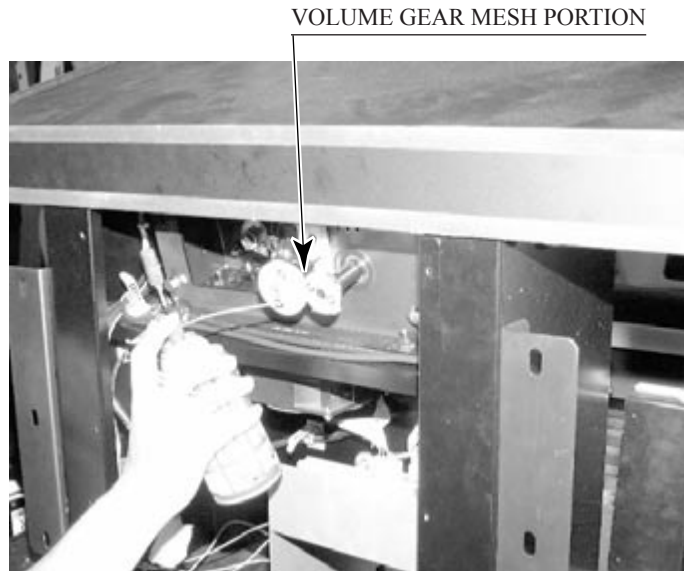

PHOTO 9. 2\*

\* Photo is different from actual Part.

## 10. 4-SPEED SHIFTER (SHIFT LEVER)



- Before starting to work, ensure that the Power SW is OFF. Failure to observe this can cause electric shock or short circuit.
- Use care so as not to damage wirings. Damaged wiring can cause electric shock or short circuit.
- Do not touch undesignated places. Touching places not designated can cause electric shock or short circuit.
- This work should be performed by the Location's Maintenance Man or Serviceman. Performing work by non-technical personnel can cause electric shock hazard.
- When performing work such as parts replacement other than those specified in this manual, be sure to contact where you purchased the product from. Confirm the work procedures and obtain precautions from where you purchased the product from prior to performing work. Inappropriate parts replacement and/or installation with erroneous adjustment can cause an overload or the parts to come into contact, resulting in an electric shock, a short circuit, and a fire.

### 10 - 1 REMOVING THE 4-SPEED SHIFTER

- ① Turn off power.
- ② Remove the 6 Truss head screws and remove the shift cover.
- ③ Remove the 6 Hexagon Bolts.

SHIFT COVER

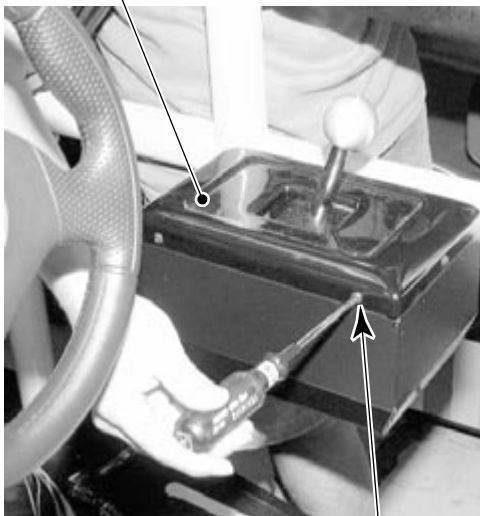

TRUSS SCREW (6) black  
M4 X 12

PHOTO 10. 1 a \*

4 SPEED SHIFTER

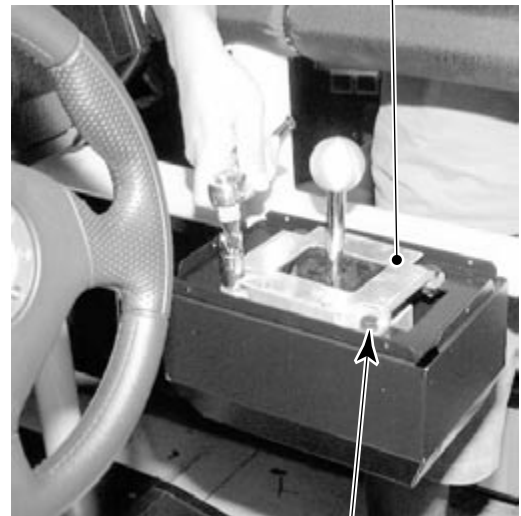

HEXAGON BOLT (4)  
M8 X 20, w/spring washer

PHOTO 10. 1 b \*

\*Photos differ from actual part



- ④ Pull up the 4-speed shifter upright. Be careful not to let the wires caught on some sections or not to let the parts hit against each other.
- ⑤ Disconnect the connectors from each other. Uncouple the 4-speed shifter. When replacing it to an original position, be careful about the installation direction. The side with the wires must face the PTV.

When replacing it to an original position, be careful about the installation direction.

\*Photos differ from actual part

Disconnect the connector.

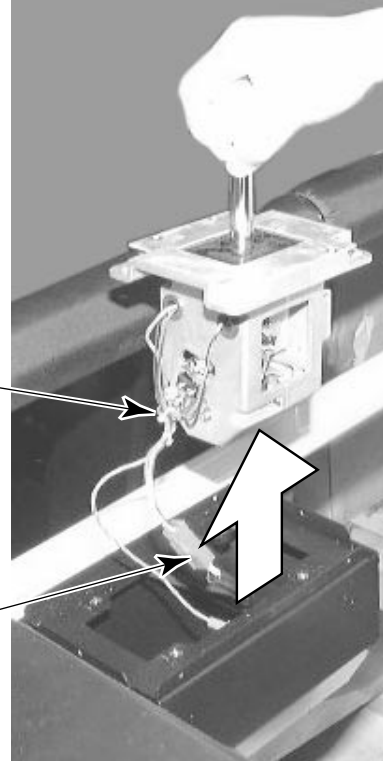
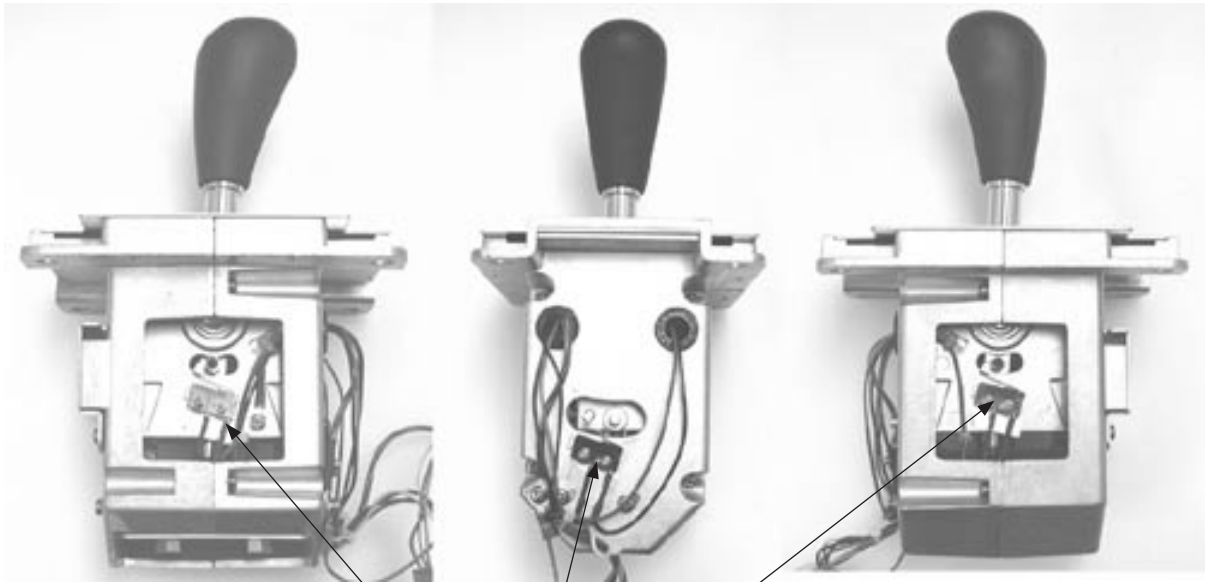

PHOTO 10. 1 c \*

## 10 - 2 REPLACING THE SWITCH

In case 4-speed Shifter operability is poor, malfunction of or damage to the Microswitch of Mechanism can be considered. The 4-speed Shifter has 3 Microswitches. Be sure to check which Switch malfunctions prior to performing work.

- ① Remove 4-speed Shifter as per procedure 10 -1.
- ② Disconnect the wiring connected to the Microswitch.
- ③ Take out 2 screws to replace the Microswitch.
- ④ Check to ensure that the Switch goes ON and OFF in consistency with the operation.



MICROSWITCH  
509-5636

PHOTO 10. 2

SCREW (2)  
M2.3 X 10, w/flat & spring washers

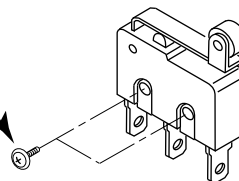

FIG. 10. 2

## 11. PEDAL DUAL (HAPP CONTROL part no. 50-2661-00-XV)



- Before starting to work, ensure that the Power SW is OFF. Failure to observe this can cause electric shock or short circuit.
- Use care so as not to damage wirings. Damaged wiring can cause electric shock or short circuit.
- Do not touch undesignated places. Touching places not designated can cause electric shock or short circuit.
- This work should be performed by the Location's Maintenance Man or Serviceman. Performing work by non-technical personnel can cause electric shock hazard.
- When performing work such as parts replacement other than those specified in this manual, be sure to contact where you purchased the product from.
- Confirm the work procedures and obtain precautions from where you purchased the product from prior to performing work. Inappropriate parts replacement and/or installation with erroneous adjustment can cause an overload or the parts to come into contact, resulting in an electric shock, a short circuit, and a fire.

If Accelerator and Brake operation is not satisfactory, adjustment of Volume installation position or Volume replacement is needed. Also, be sure to apply greasing to the gear mesh portion once every 3 months.

### 11 - 1 ADJUSTING AND REPLACING THE V.R.

The appropriate value for both ACCEL. Volume and Brake Volume is under 30H when released and over C0H when stepped on. Check Volume values in the TEST mode. Since work is performed inside the energized cabinet, be very careful so as not to touch undesignated places. Touching places not specified can cause electric shock or short circuit.

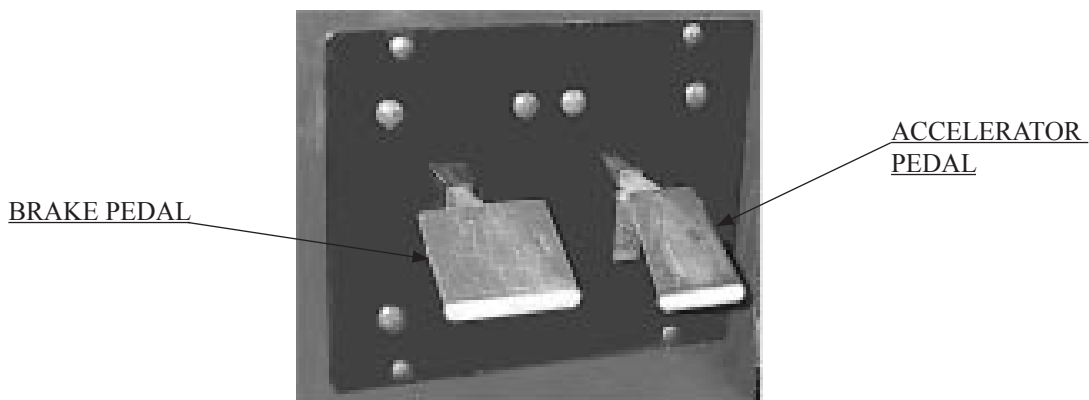

Tom Happ  
 tom.happ@happcontrols.com  
 Happ Controls  
 106 Garlish Drive  
 Elk Grove, IL. 60007  
 Ph. 847-593-6161 ext. 107  
 Fx. 847-956-2091

Visit our website <http://www.happcontrols.com>

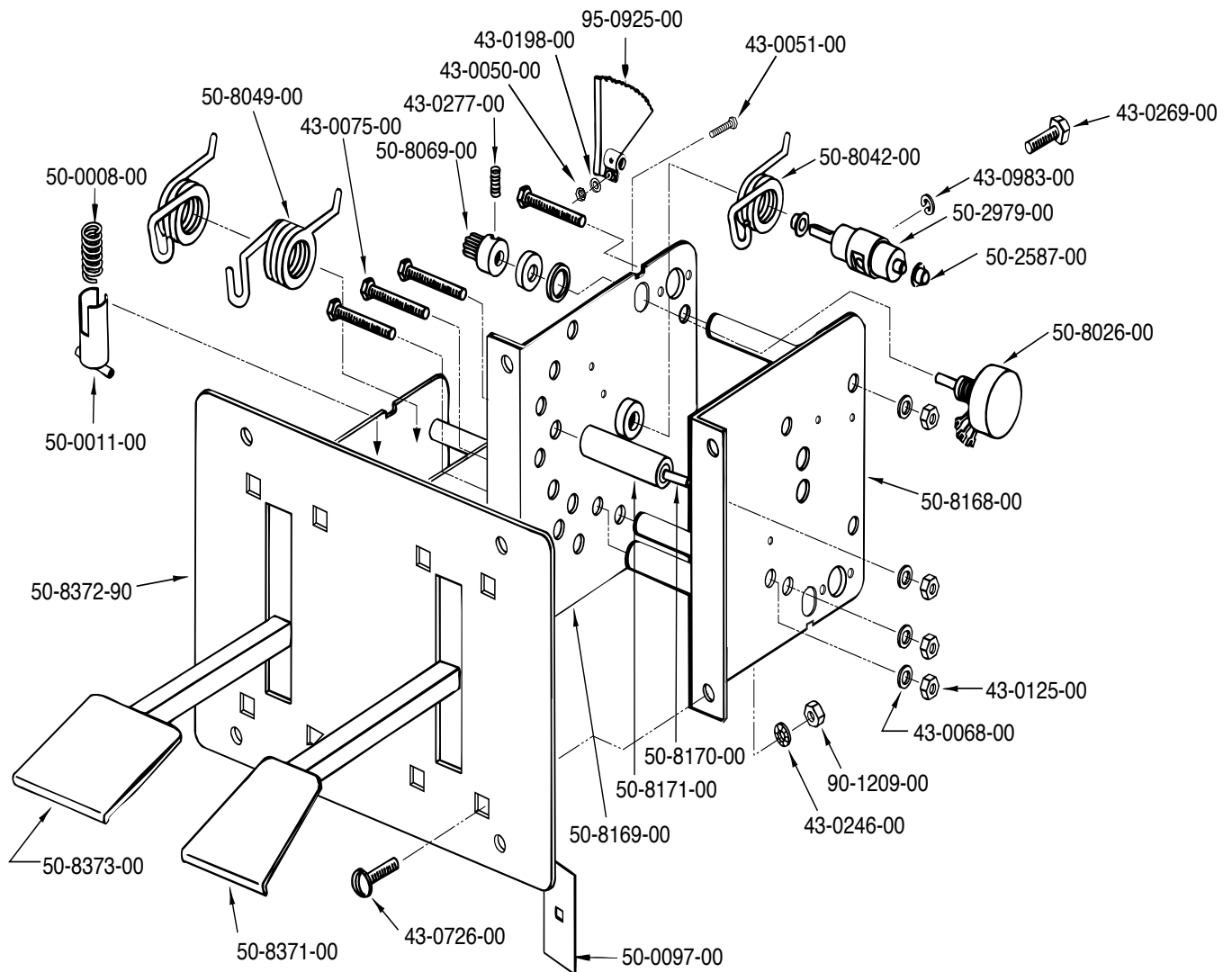

## 11 - 2 GREASING



**IMPORTANT!**

Be sure to use the designated grease. Using undesignated grease can cause parts damage.

Once every 3 months, apply greasing to the Spring and Gear mesh portion. For spray greasing, use GREASE MATE (PART No. 090-0066).

## 12. COIN SELECTOR

### HANDLING THE COIN JAM

If the coin is not rejected when the REJECT button is pressed, open the coin chute door and open the selector gate. After removing the jammed coin, put a normal coin in and check to see that the selector correctly functions.

### CLEANING THE COIN SELECTOR



- Remove and clean smears by using a soft cloth dipped in water or diluted chemical detergent and then squeezed dry.
- Never apply machine oil, etc. to the Coin Selector.
- After cleaning the Coin Selector, insert a regular coin in the normal working status and ensure that the Selector correctly functions.

The coin selector should be cleaned once every 3 months. When cleaning, follow the procedure below:

- ① Turn the power for the machine OFF. Open the coin chute door.
- ② Open the gate and dust off by using a soft brush (made of wool, etc.).
- ③ Remove and clean smears by using a soft cloth dipped in water or diluted chemical detergent and then squeezed dry.
- ④ Remove the CRADLE.  
When removing the retaining ring (E ring), be very careful so as not to bend the rotary shaft.
- ⑤ Remove stain from the rotary shaft and shaft receiving portions by wiping off with a soft cloth, etc.
- ⑥ After wiping off as per ⑤ above, further apply a dry cloth, etc. to cause the coin selector to dry completely.

### COIN INSERTION TEST

Once every month, when performing the Coin SW Test, simultaneously check the following:

- Does the Coin Meter count satisfactorily?
- Does the coin drop into the Cashbox correctly?
- Is the coin rejected when inserted while keeping the Reject Button pressed down?

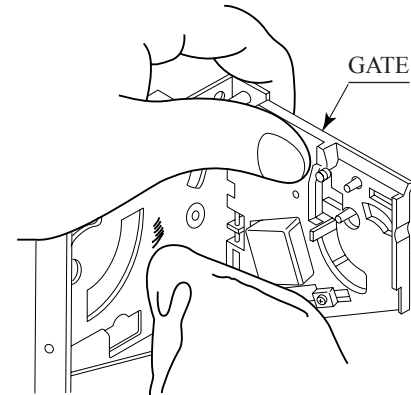

FIG. 12 a

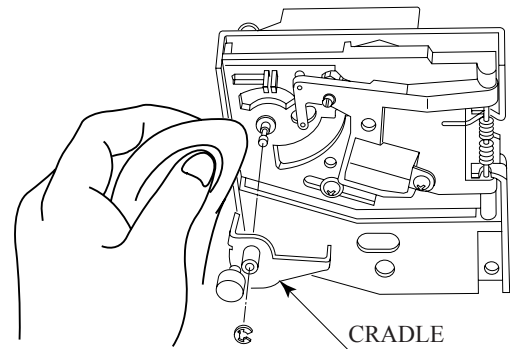

FIG. 12 b

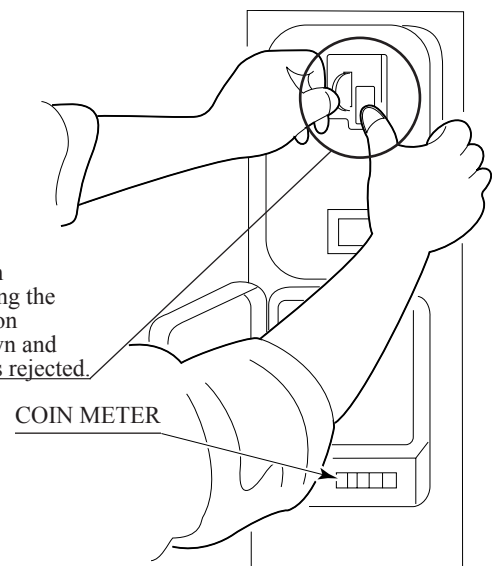

FIG. 12 c

Insert a coin while keeping the Reject Button pressed down and check if it is rejected.

WELLS-GARDNER  
ELECTRONICS CORPORATION  
2701 N. KILDARE CHICAGO, IL 60639  
1-800-336-6630

WWW.WGEC.COM

WGD15-2110-01  
OVER/UNDER MINI DOOR  
2 ENTRIES WITH BILL  
VALIDATOR BOTTOM DOOR  
& SPECIAL ENCLOSURE

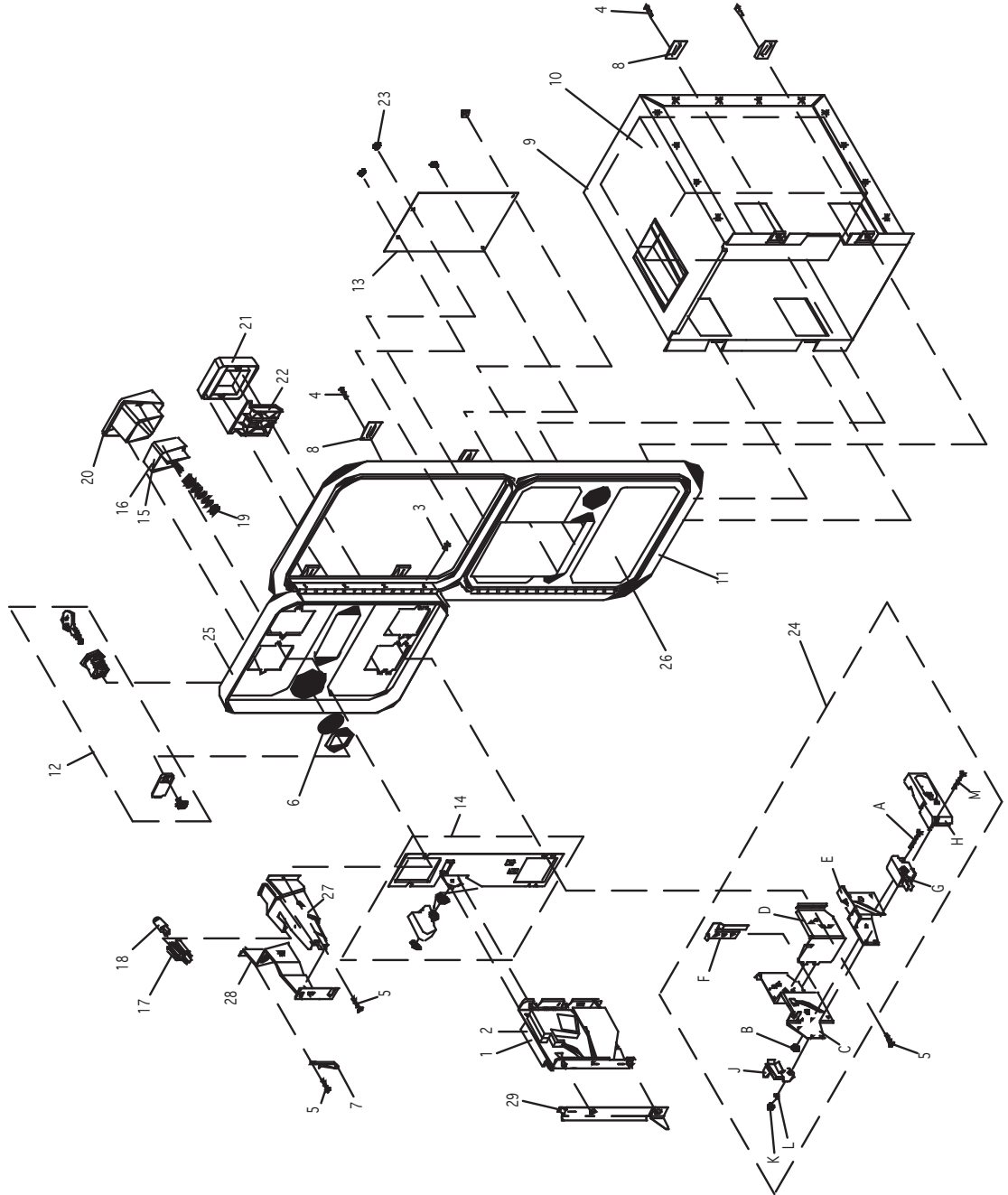

#	W.G. PART #	DESCRIPTION
1	812-4150-011	S-7 US 25c COIN MECH LEFT
2	812-4050-011	S-10 US \$1 COIN MECH RIGHT
3	890-1002-00	HINGE SCREW
4	890-1003-00	CLAMP SCREW
5	890-1017-00	SCREW TRILOBULAR
6	890-1019-00	WASHER INTERNAL TOOTH 3/4"
7	890-1300-00	KEYHOOK
8	891-0514-00	CLAMP UK 5/8" CABINET
9	025X3711-001	ENCLOSURE W/CHUTE
10	025X3712-001	METAL CASHBOX
11	891-0509-162	DOUBLE FRAME
12	891-0547-00	LOCK SINGLE BIT
13	891-0100-4016	COVER PLATE
14	891-1008-107	BASE PLATE ASSEMBLY
15	891-1113-03	E/R BUTTON US 4x25c/\$1 LEFT
16	891-1113-011	E/R BUTTON US \$1 COIN RIGHT
17	891-1117-00	LAMPHOLDER
18	891-1118-00	LAMP WEDGE BASE 6 VOLT
19	891-1121-00	SPRING, E/R BUTTON
20	891-1311-16	BUTTON BEZEL, NYLON
21	891-1312-16	REJECT BEZEL, NYLON
22	891-1109-16	REJECT FLAP
23	020X1877-005	NUT KEPS #6-32 X 5/16 HEX
24	891-2216-16	MICROSWITCH ASSEMBLY
24A	890-1007-00	SCREW FLAT HEAD W/S
24B	890-1206-02	KEP NUT
24C	891-1105-01	REJECT CUP SIDE PLATE
24D	891-1106-00	REJECT CUP BASE PLATE
24E	891-1107-00	BRACKET, MICROSWITCH
24F	891-1110-00	ADJUSTER, COIN
24G	891-1116-16	MICROSWITCH, BLACK - MED.
24H	891-1125-00	COVER, PLASTIC
24J	892-1002-07	CLIP, SNAP-ON
24K	892-1002-08	ELASTIC SNAP NUT
24L	892-1002-09	SLEEVE, SNAP-ON
24M	892-1002-11	SCREW, PAN HEAD
25	891-0604-16	MINI DOOR 2 ENTRIES
26	891-0614-16	MINI DOOR W/D BY C/O
27	892-1002-01	BRACKET, LAMP SIDE
28	892-1002-021	BRACKET, COVERSIDE
29	892-1002-10	BRACKET, HOLD DOWN

Tom Happ  
 tom.happ@happcontrols.com  
 Happ Controls  
 106 Garlisch Drive  
 Elk Grove, IL. 60007  
 Ph. 847-593-6161 ext. 107  
 Fx. 847-956-2091

Visit our website <http://www.happcontrols.com>

**EXCLUSIVE!**

Custom  
 "Guardian"  
 Security Hasp  
 available  
 to protect your  
 dollars,

**GUARDIAN**

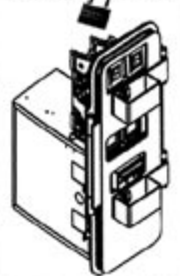

MECH HOLDER PARTS	
MECH HOLDER	42-3319-00
W/COIN SWITCH	42-7355-00
MECH HOLDER	42-7355-00
W/ID COIN SWITCH	42-7087-00
SCREW FOR COIN SWITCH	43-0136-00
METAL CLIP	42-7338-91
THUMBSCREW FOR METAL CLIP	42-7338-90

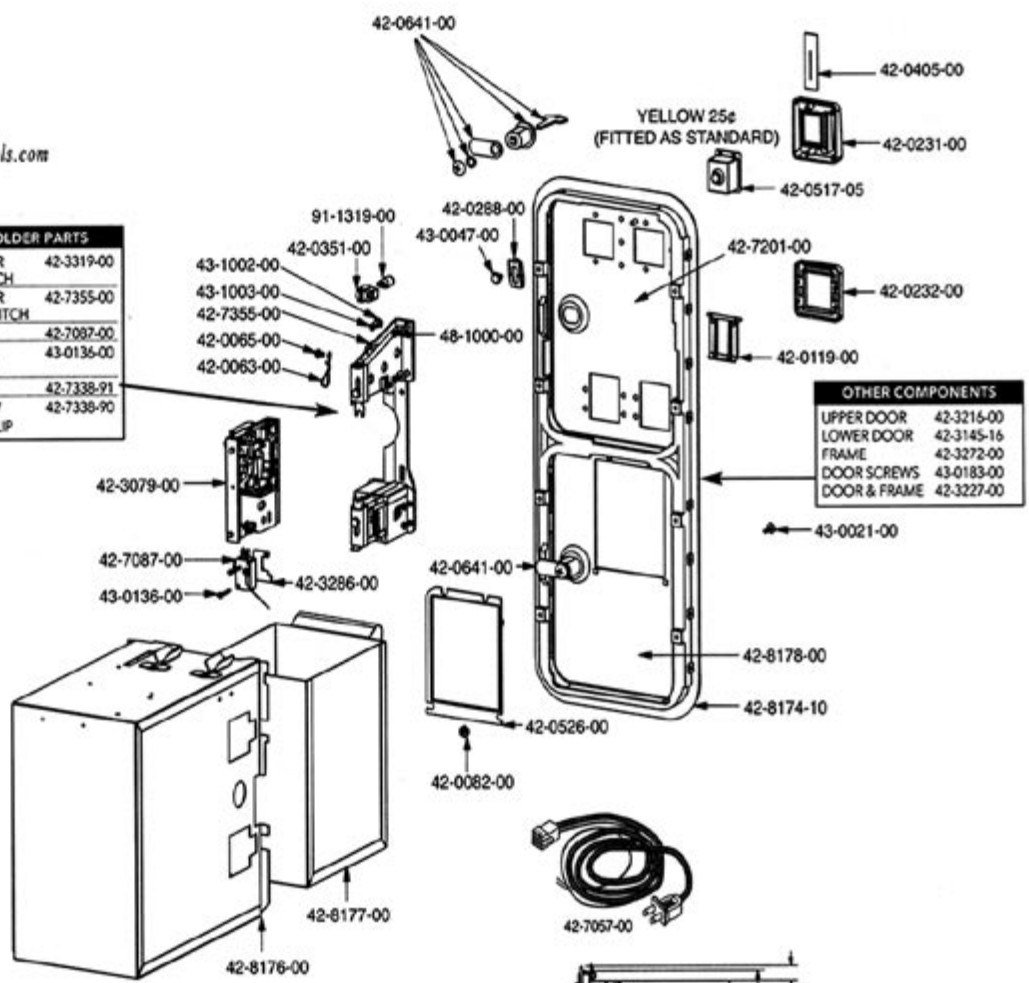

OTHER COMPONENTS	
UPPER DOOR	42-3216-00
LOWER DOOR	42-3145-16
FRAME	42-3272-00
DOOR SCREWS	43-0183-00
DOOR & FRAME	42-3227-00

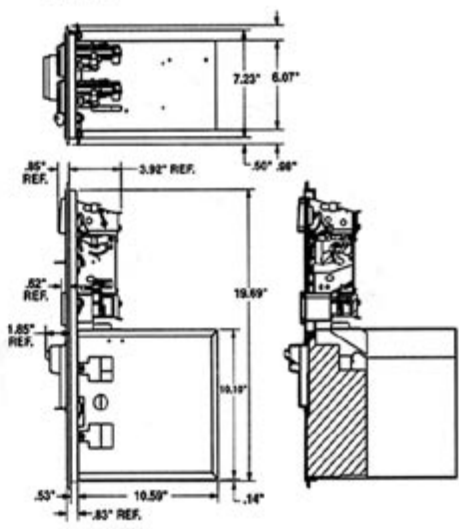
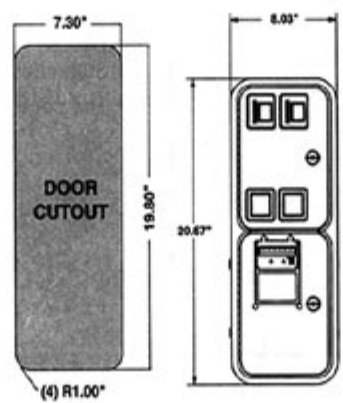
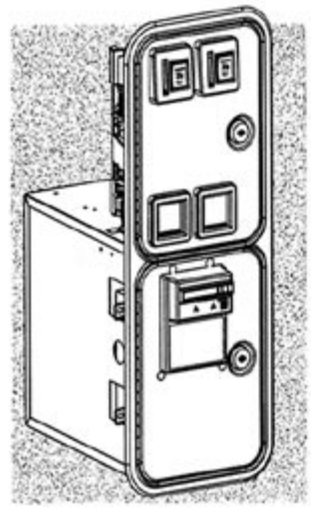

## OPTIONAL DOLLAR BILL ACCEPTOR

- THE COIN DOOR ASSEMBLY USED ON **NASCAR MINI STANDARD** COMES EQUIPPED TO ACCEPT A DOLLAR BILL ACCEPTOR. ALL NEEDED WIRING CONNECTIONS ARE CONVENIENTLY LOCATED INSIDE THE GAME FOR THIS APPLICATION.
- THE COIN DOOR CAN ACCOMMODATE THE FOLLOWING VALIDATOR(S):

FORWARD-MOST Mars 2000 series  
HOLE POSITION

\*\*42-1155-00 MARS VALIDATOR \$1, 2, 5 300 CAP

The frame and cashbox enclosure on this coin door has been modified to accommodate a Mars 2000 series upstacker. A 2000 series stacker can be added by simply removing the cut-out plate. This one entry door can be ordered through Happ Controls or one of Happ Controls authorized distributors. The part number is 40-6000-10EX. The Mars stacker can be obtained through an authorized Mars distributor.

Note: Your game may have either Happ Controls Coin Door Assembly or the Wells Gardner Coin Door Assembly (not shown).

\*\*Happ part number

Security Locking Bar/Bracket Set Part No.# 999-0966

Modified Cash Box (For use when DBA installed)  
Part No. # 999-1106

Plastic Cash Box - Full Size Part No. # 999-1177



### 13. REPLACING THE FLUORESCENT LAMP, AND LAMPS



- When performing work, be sure to turn power off. Working with power on can cause electric shock and short circuit hazards.
- The Fluorescent Lamp, when it gets hot, can cause burn. Be very careful when replacing the Fluorescent Lamp.
- Be sure to use lamps of the designated rating. Using lamps of undesigned rating can cause a fire or malfunctioning.



- To perform work safely and securely, be sure to prepare a step which is in a secure and stable condition. Performing work without using the step can cause violent falling down accidents.
- Be careful when handling the plastic made parts. Failure to observe this may cause injury due to damage or fragments resulting from damage.

#### INSIDE THE BILLBOARD

Remove the billboard holder, slide up the billboard plate, and replace the fluorescent tube.

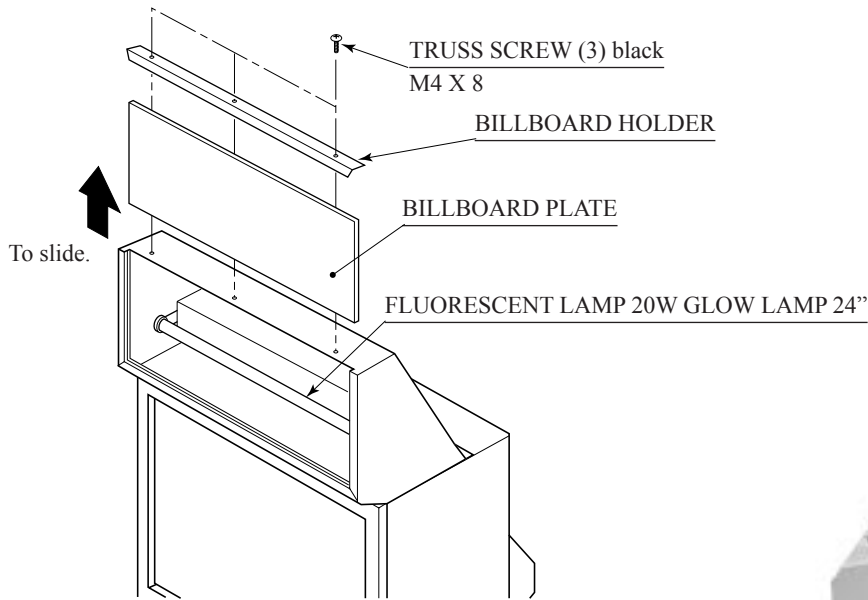

FIG. 13 a



FIG. 13 b

When performing work, prepare a step.

## START BUTTON, VIEW CHANGE BUTTON

- ① Turn power off.
- ② Remove the 4 Truss head screws.

TRUSS SCREW (4)  
M4 X 8, chrome



PHOTO 13 a

- ③ On the rear side of the control panel remove the wire connection part from the button body carefully without damaging the wires.



- ④ The lamp is inside the wiring connecting portion. Push and then turn the Lamp counterclockwise to remove.

PHOTO 13 b

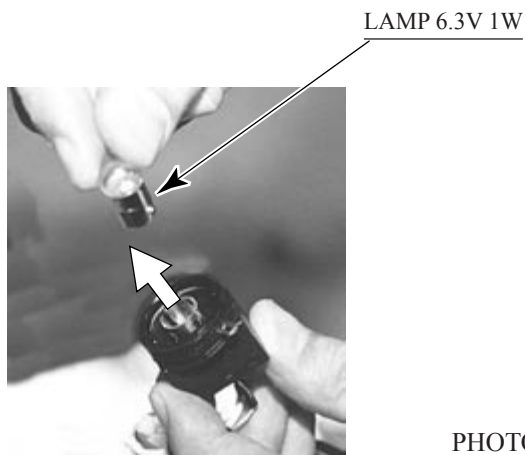

PHOTO 13 c

## 14. PERIODIC INSPECTION TABLE

The items listed below require periodic check and maintenance to retain the performance of this machine and to ensure safe business operation.

When handling the controller, the player will be in direct contact with it. In order to always allow the player to enjoy the game, be sure to clean it regularly. Also, it is advisable to provide wet tissue, etc. available for player use.



- Be sure to check once a year to see if Power Cords are damaged, the plug is securely inserted, dust is accumulated between the Socket Outlet and the Power Plug, etc. Using the product with dust as is accumulated can cause fire and electric shock hazards.
- Periodically once a year, request the place of contact herein stated or the distributor, etc. where the product was purchased from, as regards the internal cleaning. Using the product with dust as is accumulated in the interior with out cleaning can cause a fire or accident. Note that cleaning the interior parts can be performed on a pay-basis.

TABLE 16

	Item	Interval	Reference
CABINET	Check Adjusters' contact with surface.	Daily	3
CONTROL PANEL	Cleaning	As necessary	
	Inspection of SW, VR.	Monthly	8
	Greasing to the gear mesh portion.	Trimonthly	9-2
4-SPEED SHIFTER	Inspection of SW.	Monthly	8
PEDAL DUAL	Check VOLUME VALUE.	Monthly	8
	Gear and Spring portion greasing	Trimonthly	11-2
COIN CHUTE DOOR	Check COIN SW.	Monthly	8
	Coin insertion test.	Monthly	12
	Cleaning of COIN SELECTOR.	Trimonthly	12
MONITOR	SCREEN cleaning.	Weekly	
	Check adjustments.	Monthly or when moving.	5, 8, 11
GAME BD	MEMORY TEST.	Monthly	8
	Check settings.	Monthly	8
INTERIOR	Cleaning	Annually	See above.
POWER SUPPLY PLUG	Inspection and cleaning	As necessary.	See below.
Cabinet surfaces	Cleaning		

### CLEANING THE CABINET SURFACES

When the cabinet surfaces are badly soiled, remove stains with a soft cloth dipped in water or diluted (with water) chemical detergent and squeezed dry. To avoid damaging surface finish, do not use such solvents as thinner, benzine, etc. other than ethyl alcohol, or abrasives, bleaching agent and chemical dust cloth.

# 15. TROUBLESHOOTING



- In order to prevent electric shock and short circuit, be sure to turn power off before performing work.
- Be careful so as not to damage wirings. Damaged wiring can cause electric shock or short circuit.
- After removing the cause of the functioning of the Circuit Protector, reinstate the Circuit Protector. Depending on the cause of the functioning, using the Circuit Protector as is without removing the cause can cause generation of heat and fire hazard.

In case a problem occurs, first check wiring connector connections.

TABLE 15 a

PROBLEMS	CAUSE	COUNTERMEASURES
With Main SW ON, no activation.	Power is not supplied.  Power supply/voltage is not correct.  The Circuit Protector functioned due to the momentary overload.	Securely insert the power plug into the plug socket.  Make sure that power supply/voltage is correct.  After eliminating the cause of overload, reinstate the AC Unit's Circuit Protector (see [4], Sec. 5, Refer to the following). Reset the circuit protector on the ASSY ELEC. (See PHOTO 15 a, b)
The color on Monitor screen is incorrect.	Image adjustment is inappropriate.	Adjust appropriately.
Color deviation on monitor screen.	Affected by peripheral machines or the building's steel frames.	Change installation direction or position.  Move the machine which causes the problem.
No sound is emitted.	Sound volume adjustment is not appropriate.  Board and Amplifier malfunctioning.	Adjust sound volume (see Sec. 8).  Perform the sound test and confirm (See Sec. 8).

CIRCUIT PROTECTOR

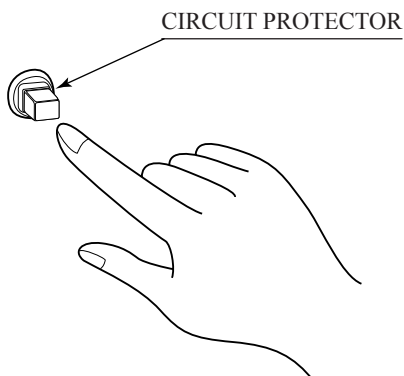

Functions due to the activation of bimetal. To restore the function, wait for approximately one minute or longer until the bimetal cools off. (Press the Button.)

TABLE 15 b

PROBLEMS	CAUSE	COUNTERMEASURES
Operability of the Steering wheel (handle) is poor.	Deviation of the volume value.  Volume gear engagement fault.  Volume malfunctioning.	Adjust the volume value in the Test mode. (See 8-3)  Adjust the engagement of the gear. (See 9-2)  Replace the Volume. (See 9-2)
Shifter does not operate normally.	Failure of the switch.	Replace the switch. (See 10-2)
Pedal Dual (accelerator) and/or brake pedal do not operate normally.	The volume is not centered.  Failure of the volume.	Adjust the volume value in the test mode. (See Sec. 8)  Replace the volume. (See 11-1)
The Fluorescent lamp does not light up.	The Fluorescent tube is burnt out.	Replace the Fluorescent tube (See Sec. 13).
Lights integrated with the start button and the view change button do not come on.	The lamp is burnt out.	Replace the lamp. (See Sec.13)
Failure of the communication play.	Communication cables are disconnected.  Communication cables are wrongly connected.  Communication play is wrongly set.	Reconnect the cables. (See 17-2)  Reconnect the cables correctly. (See 17-2)  Reset correctly. (See 17-3)

## 16. GAME BOARD



- In order to prevent electric shock and short circuit hazards, be sure to turn power off before performing work.
- Be careful so as not to damage wirings. Damaged wiring can cause fire, electric shock and short circuit hazards.
- Do not expose the Game BD, etc. without a good reason. Failure to observe this can cause electric shock hazard or malfunctioning.



The electronic parts on the IC Board could be damaged due to human body's static electricity. Before performing IC Board related work, be sure to discharge physically accumulated statics by touching grounded metallic surfaces, etc..



Put the Game Board in the Carton Box (an accessory) together with the Shield Case when requesting for the replacement or repair. Transporting the Game Board in an undesignated status for replacement/repair is unacceptable. In this manual, how to remove the Game Board is explained for convenience. However, this work should be performed by SEGA SERVICEMAN.

## 16 - 1 REMOVING THE GAME BOARD

- ① Turn power off.
- ② Remove the 2 truss head screws of the back lid, unlock it, and detach it from the main cabinet.
- ③ Disconnect the connectors of all the wires between the ASSY MAIN BD STD and the main cabinet.
- ④ Disconnect the connectors of all the wires between the shield case's filter board on the ASSY MAIN BD STD and the main cabinet.
- ⑤ Remove the 2 wing bolts that fix the base (a wooden plate) of the ASSY MAIN BD STD.

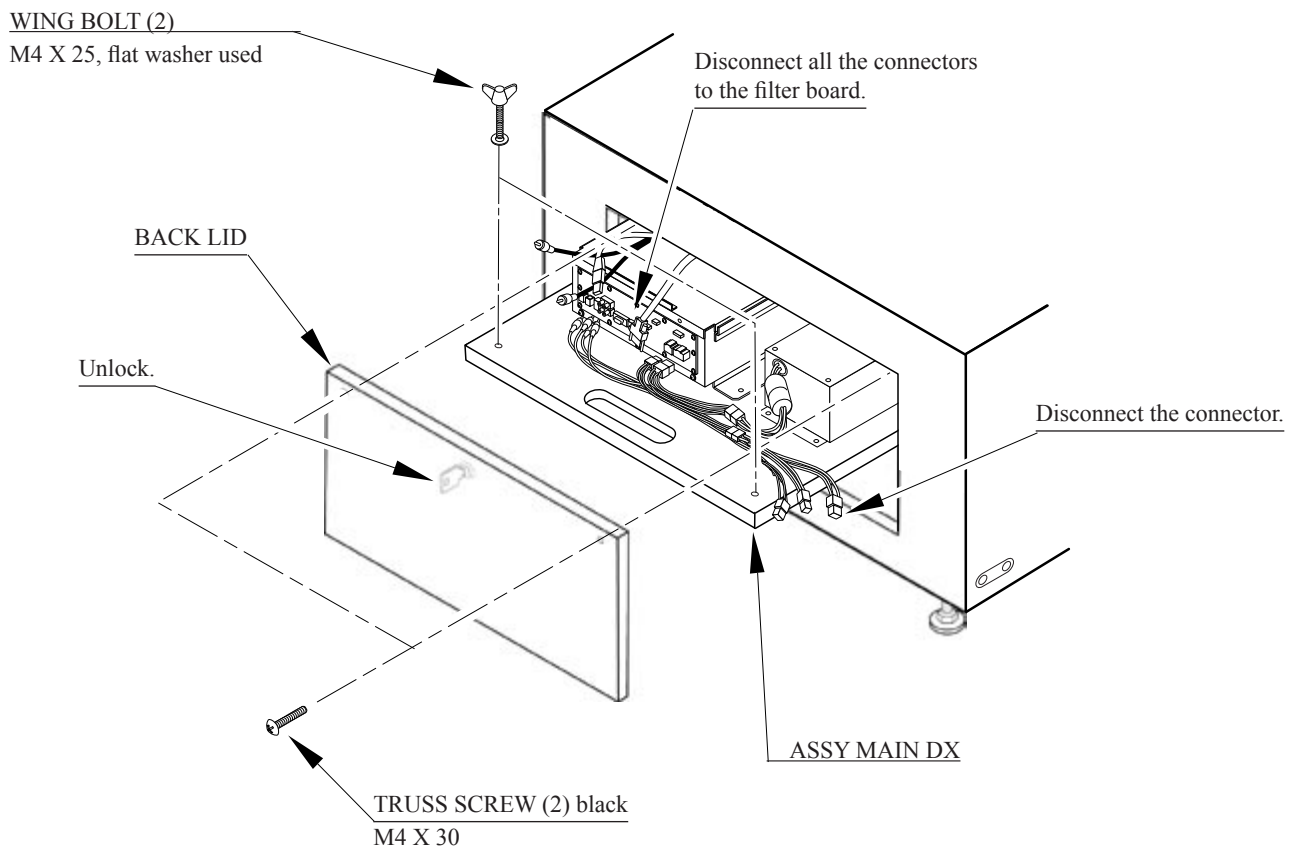
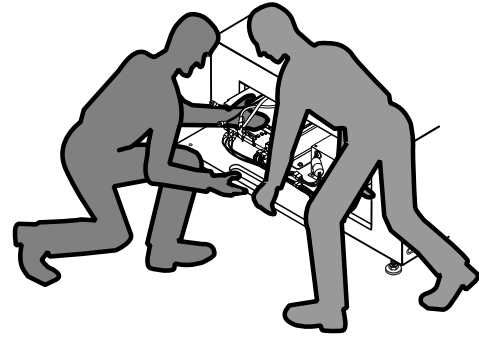

FIG. 16. 1 a

- ⑥ Draw out the ASSY MAIN BD STD from the main cabinet. More than two workers must engage in this action. Note that the ASSY MAIN BD STD is heavy, and, if a single worker draws out it alone, he/she may damage the wires by snagging or catching the wires on other parts.  
NOTE: If you remove the 3 screws and detach the shield case lid, you can access to the game board. This action is allowed, however, only for the Sega's service engineer.



To perform work safely,  
use 2 or more workers.

FIG. 16. 1 b

- ⑦ Remove the 4 screws that fix the shield case onto the base (a wooden plate), and detach the former from the latter.
- ⑧ Remove the 2 screws each, and detach the shield case from the shield case brackets. Wrap the shield case with protective shipping materials, and contain it in a carton box. Send it for repairing.

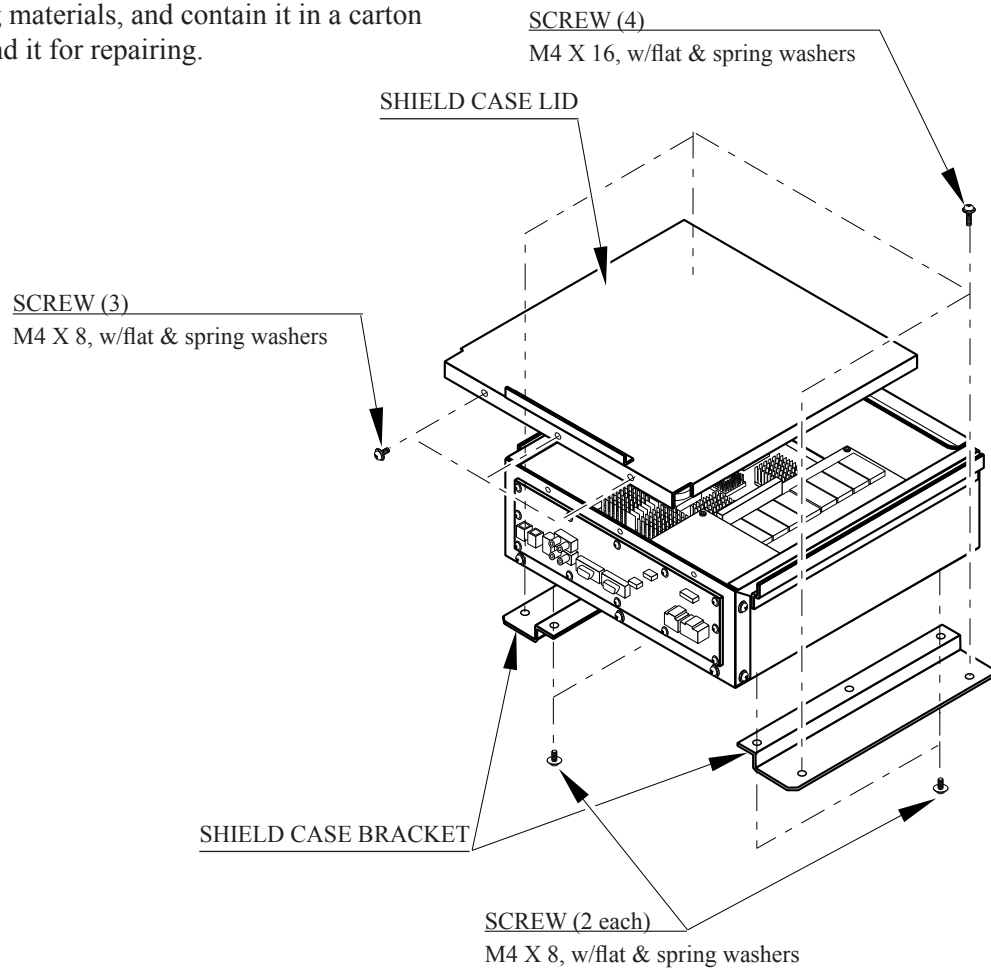

FIG. 16. 1 c



16 - 2 COMPOSITION OF GAME BOARD

GAME BD NCR (833-14033)

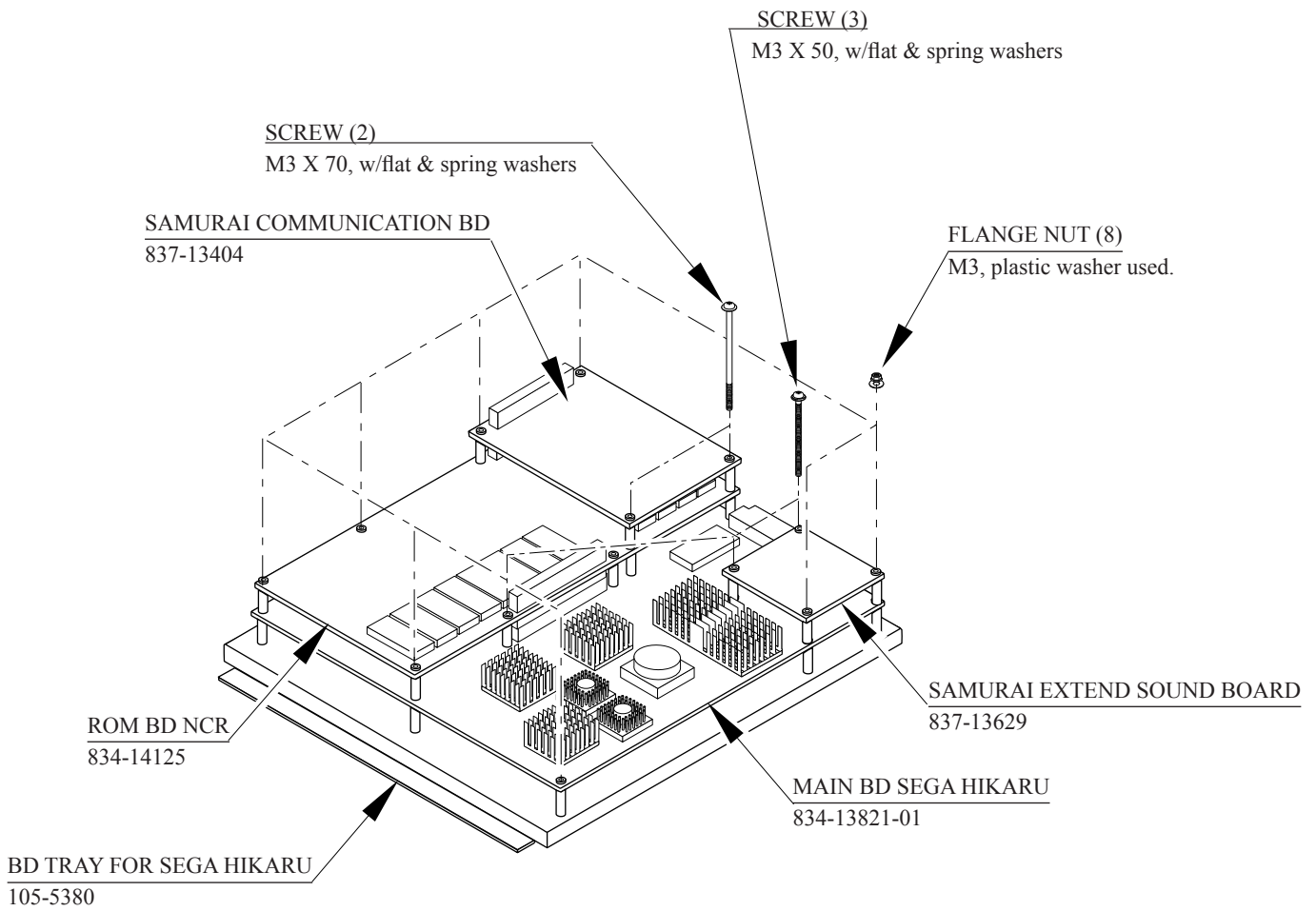

FIG. 16. 2

ROM BD JUMPER SETTING	
JP3	2-3
JP4	2-3
JP5	2-3
JP6	2-3

MAIN BD JUMPER SETTING	
JP4	1-2
JP5	1-2
JP6	1-2
JP7	1-2
JP8	2-3
JP9	2-3
JP10	1-2
JP11	2-3

## 17. COMMUNICATION PLAY

For this game, up to 8 machines can be connected to allow up to 8 players to play simultaneously. In this instance, connecting the communication cable and setting for the communication play are required.

### 17 - 1 INSTALLATION PRECAUTIONS



- Before starting to work, ensure that the Power SW is OFF. Failure to observe this can cause electric shock or short circuit.
- Use care so as not to damage wirings. Damaged wiring can cause electric shock or short circuit.
- Do not touch undesignated places. Touching places not designated can cause electric shock or short circuit.
- This work should be performed by the Location's Maintenance Man or Serviceman. Performing work by non-technical personnel can cause electric shock hazard.
- When linking a number of machines, be sure to supply sufficient power for the corresponding number of machines. Be sure to secure per machine current as stated in this manual. Failure to observe this can cause a fire and an electric shock accident.
- Due to the length of the communication cable, the distance in between the machines is limited. However, to avoid accidents, be sure to secure space in excess of 70 cm between the machines.
- To perform work safely and avoid serious accident such as the cabinet's falling down, do not perform work in places where step-like grade differences, a ditch, or slope exist.



To perform work safely, be sure to secure the space corresponding to number of machines to be linked. Failure to observe this can cause accident.



The optic fiber cable is used for the communication linkage. Excessive bending may damage the communication cable. Be very careful in this regard.

Since 2 or more machines are to be linked, sufficient power corresponding to the number of machines used need to be supplied. Note that as a standard, the per machine capacity should be 15A for the 100 ~ 120V area, and 7A for the 220 ~ 240V area.

## DISTANCE BETWEEN MACHINES

Be sure to secure space in excess of 70cm between machines.

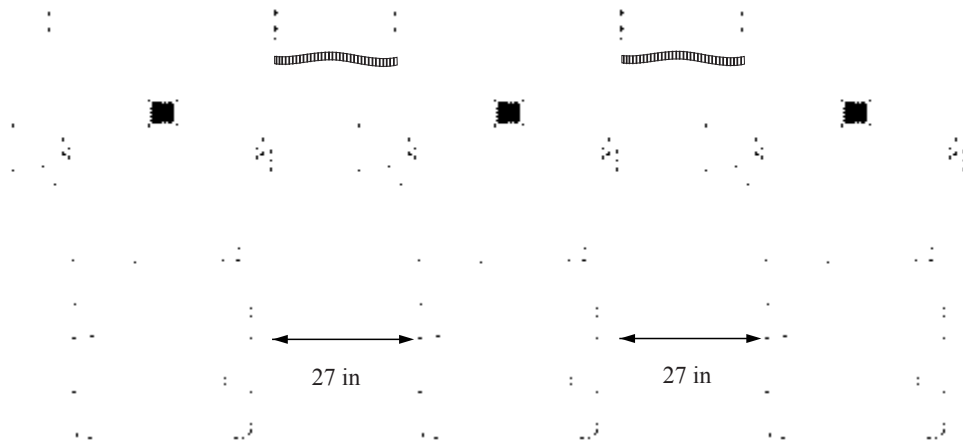

FIG. 17.1 \*

\* Photo may differ from actual game.  
For reference only.

### 17 - 2 CONNECTING THE COMMUNICATION CABLE

To enable the game machines to serve in a communication play, you must interconnect their game boards with the communication cables (optical fiber cables).

As for a wiring of the communication cables within the main cabinet (between the game board and the connector plate), Sega has completed it before shipping. Each connector plate has two connectors. Use them to wire the communication cables between one game machine to the next; thereby you can interconnect all the game boards. For this wiring, prepare in advance some standard accessories: communication cable, and 2 sets of number sticker. (For this example)

- ① Turn off power and disconnect the plug. From the viewpoint of protecting, disconnect the power cord.

- ② Wire the communication cables. A wiring method (connecting which connector to which connector) varies depending on the number of the game machines to interconnect. Wire exactly according to the illustration below. For the number other than in the illustration, always connect the TX of one game machine to the RX of the other, and thereby make a loop of the communication cable finally. (Fig. 17. 2f)

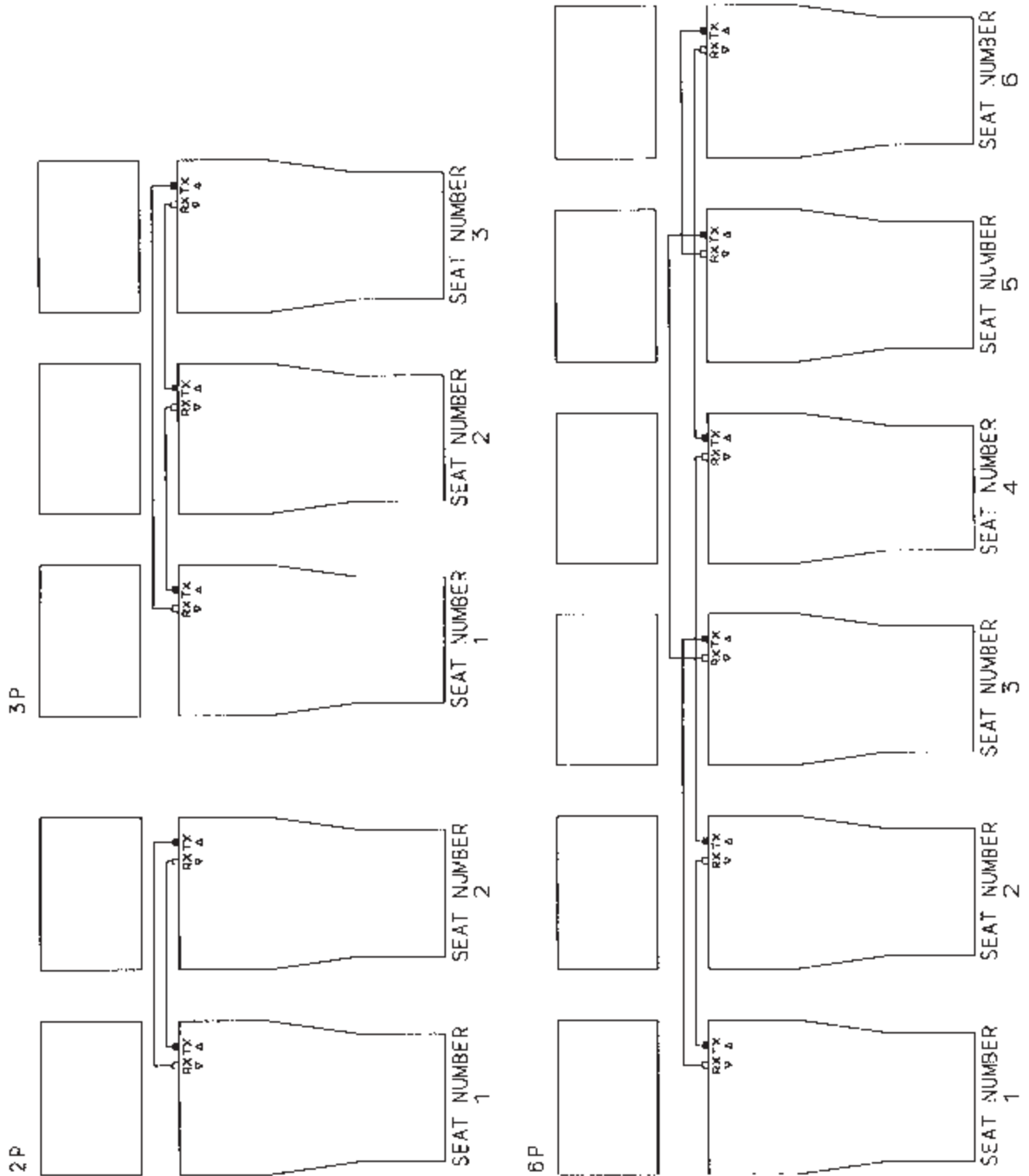
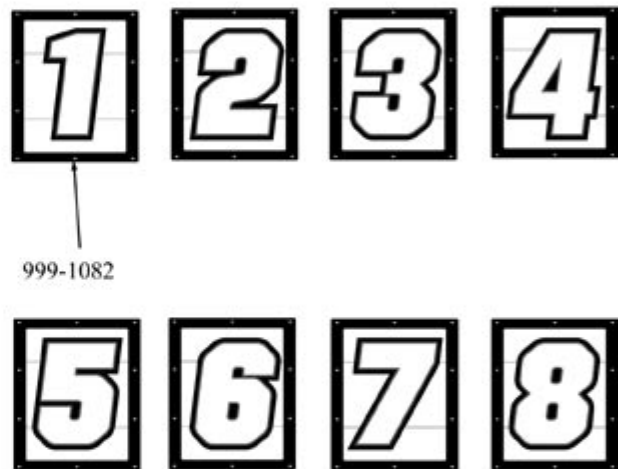
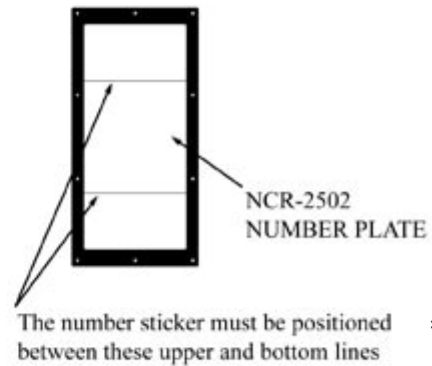
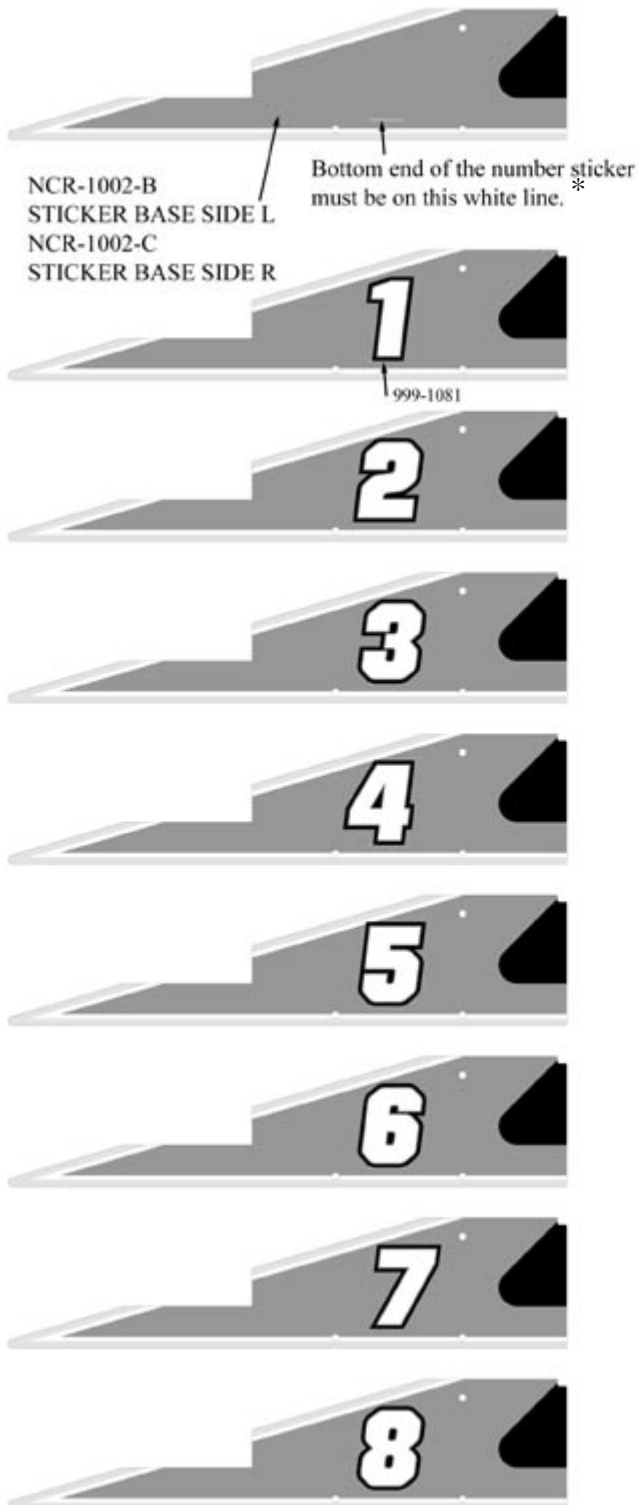

FIG. 17. 2 f

- ③ Arrange the game machines. See Chapter 6 for the precautions in transportation. Keep a space between the game machines as wide as possible.
- ④ Contact the adjusters of all the game machines to the floor. (Sec. 5 3)
- ⑤ Connect the power cords.
- ⑥ Put the number stickers on the game machines from left to right. (Fig. 17. 2g)



\* NUMBER PLATES ARE NOT NECESSARY FOR THE MINI STANDARD VERSION

\* STICKER BASE MAY DIFFER FROM PHOTO

FIG 17. 2 g

## 17 - 3 SETTING FOR COMMUNICATION PLAY



During communication play, if the test mode is not finished within 3 minutes on all the linked machines, the NETWORK CHECK cannot be performed, causing NETWORK ERROR.

Change the game setting for each seat in a manner so as to meet communication play. If the setting is not correct, communication play cannot be played.

### SETTING FOR COMMUNICATION PLAY

- ① Turn the linked machines' power on.
- ② Cause all of the machines to enter the test mode.
- ③ Select the SYSTEM ASSIGNMENTS.
- ④ Perform the COMMUNICATION MODE setting in the SYSTEM ASSIGNMENTS screen. Set one of the machines to MASTER and all others to SLAVE. Set to RELAY for exclusive use of LIVE Monitor.

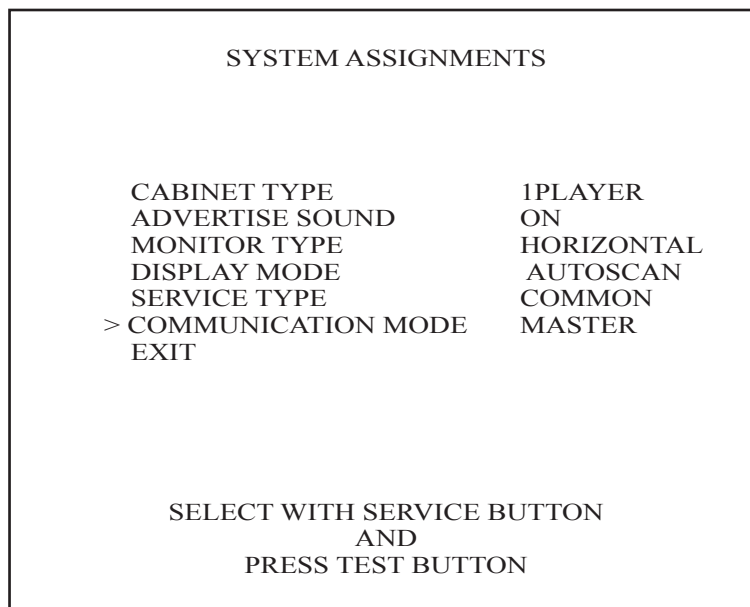

FIG. 17.3 a

- ⑤ Activate the game test mode. (8-3)
- ⑥ Select and open the GAME ASSIGNMENTS screen. Note that the screen looks different between the MASTER and SLAVE game machines.
- ⑦ Perform the SEAT NUMBER setting in the GAME ASSIGNMENTS screen. Set the machines sequentially to No.1, No.2, No.3, and so on as applicable starting from the extreme left facing the monitor's front side. Set every seat number correctly without duplication.

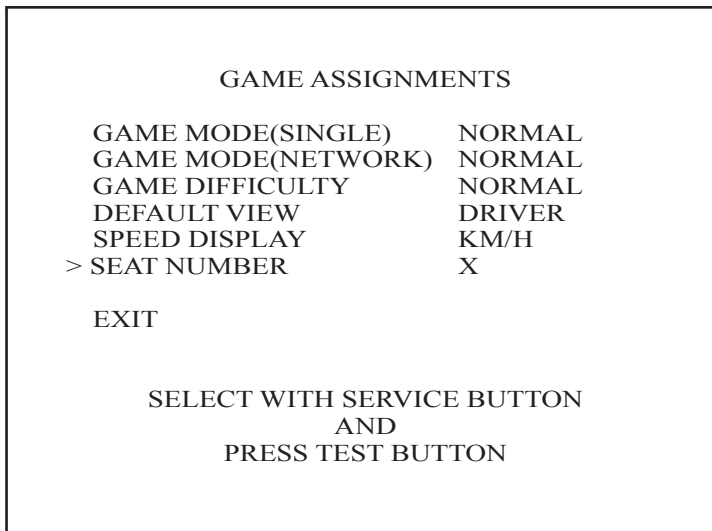

FIG. 17. 3 b

Cause all of the machines to exit from the test mode. After the test mode, the screens proceed to and display the NETWORK CHECK.

When a network-checking is finished, the system displays an advertisement screen. This means a successful completion of setting. If any seat number is duplicated, an error message appears on the screen. Normally the NETWORK CHECK takes less than one minute. If the screen does not proceed from the NETWORK CHECK screen, some sorts of errors such as incorrect setting, or incorrect connection or malfunctioning of the communication cable can be considered.

#### 17 - 4 CAUTIONS TO BE HEEDED DURING COMMUNICATION PLAY



- With a communication play, the ADVERTISE SOUND and GAME DIFFICULTY items can be set only on the MASTER game machine. New settings by the MASTER game machine become effective to all the interconnected game machines.
- If any setting is inadequate or if the communication cables are improperly connected, the system keeps displaying the network-checking screen or an error message. If this is the case, you cannot play the game.
- During communication play, if communication is interrupted due to some cause, the game is discontinued and the NETWORK CHECK screen is displayed.
- If one of the linked machines enters the test mode, all others display the NETWORK CHECK screen.

Machine's operation when linked for communication play alters comparing to that of when independently operated. Be careful of this point. As described above, some setting items must be set only on the MASTER game machine. They cannot be set on any SLAVE game machines or, if set, will not become effective. When any game machine is in a test mode, a network-checking screen appears on the other game machines interconnected for a communication play. While a guest is using any one of the interconnected game machines, therefore, do not activate a test mode even on the unused game machine.

# 18. DESIGN RELATED PARTS

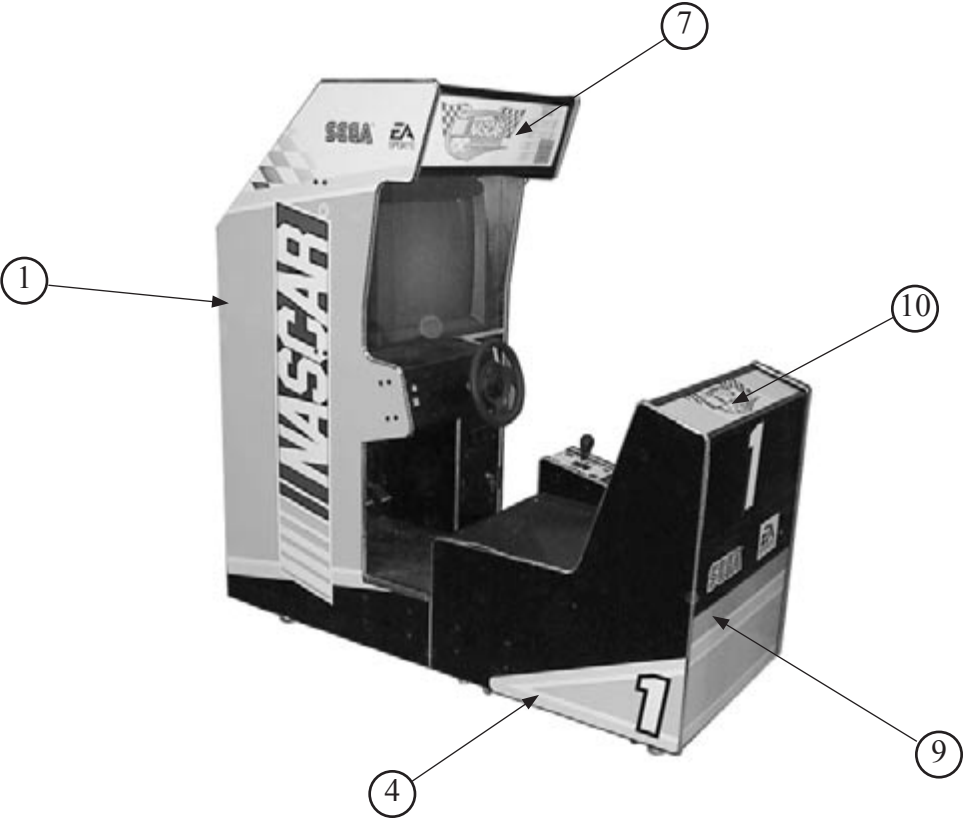
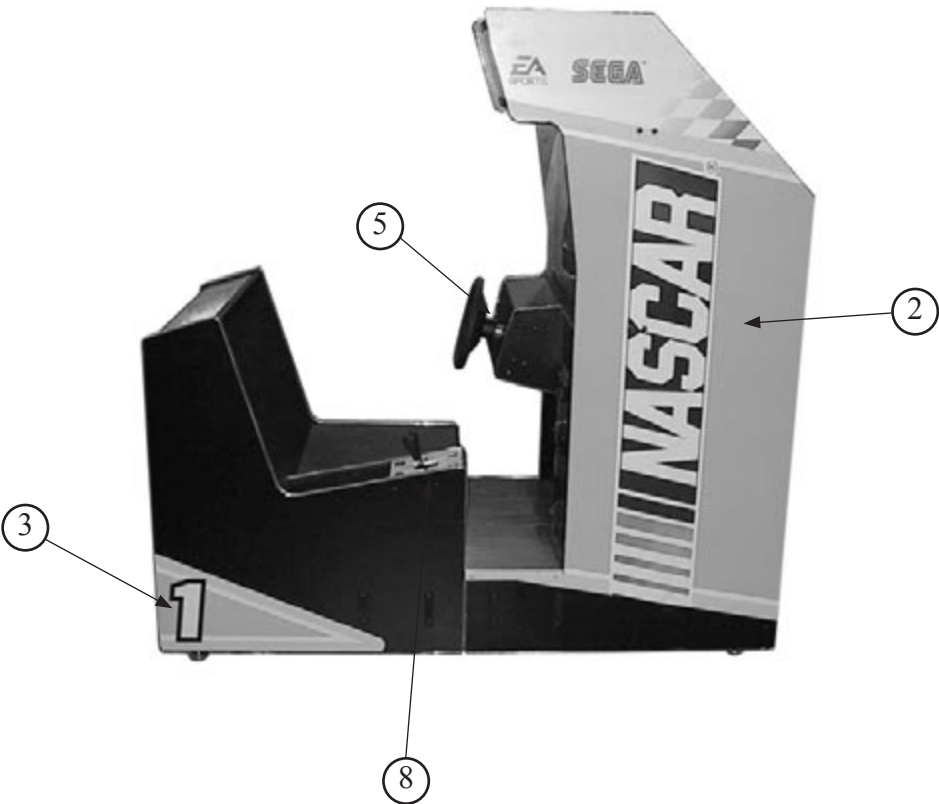



ITEM NO.	PART NO.	DESCRIPTION
NOT SHOWN	999-1062	PANEL DISPLAY POP
1	999-1072	DECAL CABINET LEFT SIDE 6-COL.
2	999-1073	DECAL CABINET RIGHT SIDE 6-COL.
3	999-1077	DECAL SEAT RIGHT SIDE
4	999-1076	DECAL SEAT LEFT SIDE
5	999-1063	DECAL CONTROL PANEL
6	N/A	
7	999-1428	DISPLAY MARQUEE
8	999-1431	DECAL SHIFTER
9	999-1075	DECAL SEAT BACK REAR
10	999-1074	DECAL SEAT BACK TOP
NOT SHOWN	999-1081	DECAL SIDE NUMBERS #1 - 8
NOT SHOWN	999-1082	DECAL # PLATE # 1 - 8

## 19. PARTS LIST

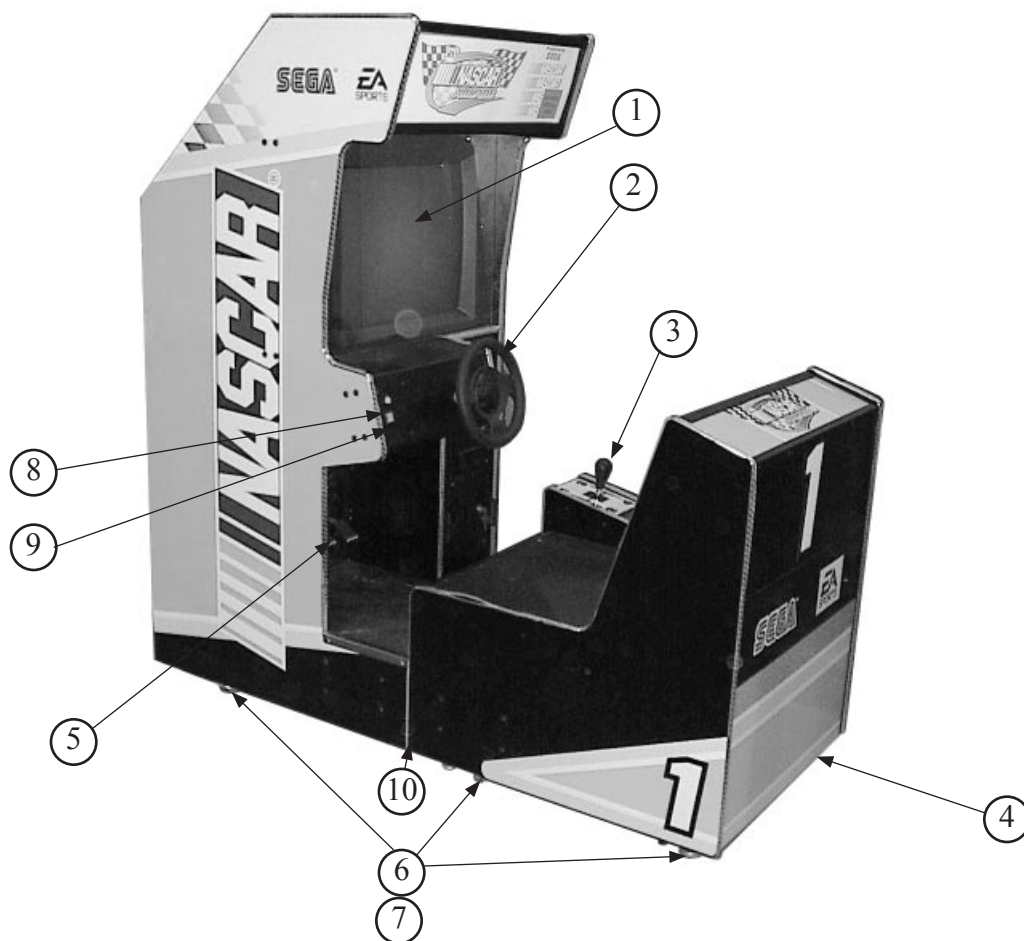

ITEM NO.	PART NO.	DESCRIPTION
1	WGM-2972*UOT-529K	29" MONITOR (WELLS GARDNER)
2	50-2838-00-XV	WHEEL STEERING (HAPP CONTROLS)
3	SPG5-2150	4-SPEED SHIFTER
4		SEAT
5	50-2661-00-XV	PEDAL DUAL (HAPP CONTROLS)
6	999-0167	LEG LEVELER 1/2-13 X 3"
7	999-0169	CASTER 160-2 1/2
8	999-1069	PUSH BUTTON SMALL RND
9	999-1070	PUSH BUTTON RECT. VLT
10	999-1427	BRACKET AND BOLTS

# AC UNIT

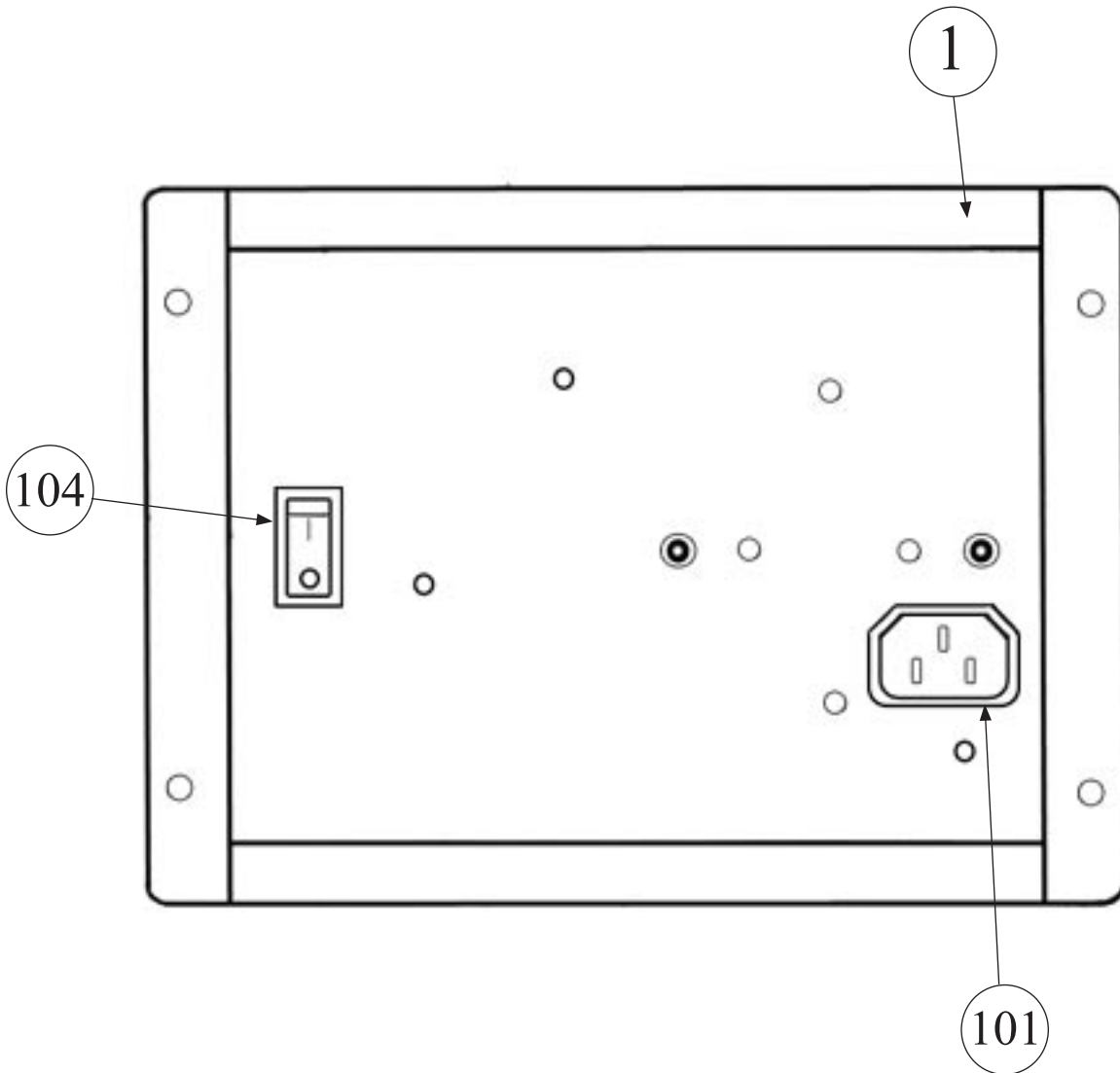

ITEM NO.	PART NO.	DESCRIPTION
1	999-1043	AC BRKT
NOT SHOWN	DYN-0402	NOISE FILTER BASE
NOT SHOWN	421-8202	STICKER EARTH MARK
101	999-1044	AC INLET PANEL TYPE
104	999-0676	SW ROCKER J8 V-B

# ASSY CONNECTOR PLATE (NCR-1080)

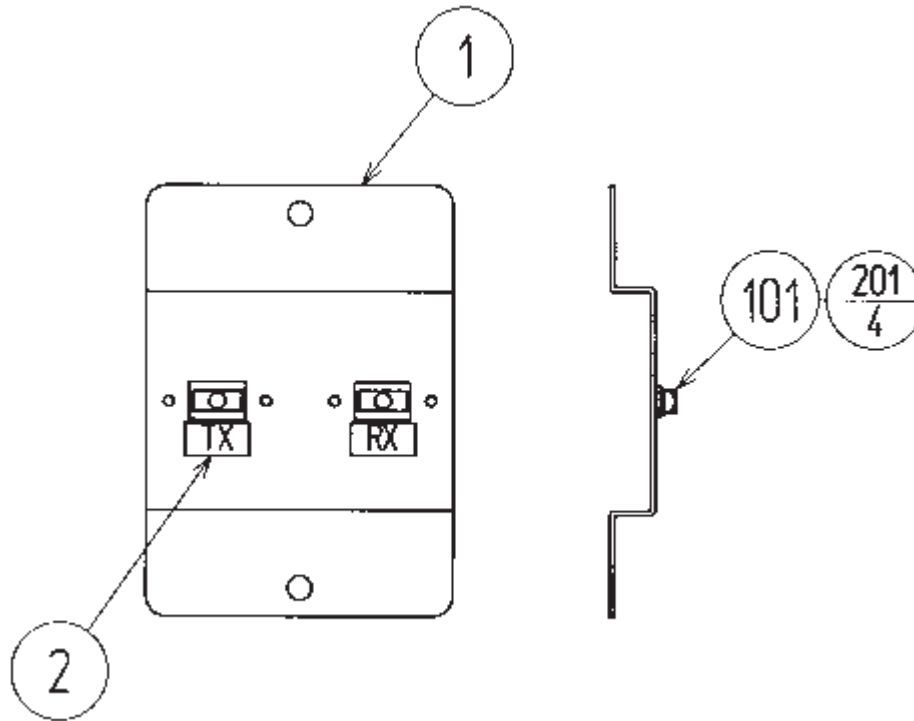

ITEM NO.	PART NO.	DESCRIPTION
1	NCR-1081	CONNECTOR PLATE
2	421-7515	STICKER FIBER CABLE TX/RX
101	211-5479-01	CONN OPT JOINT
201	000-P00312-W	M SCR PH W/FS M3 X 12

# ASSY BILLBOARD

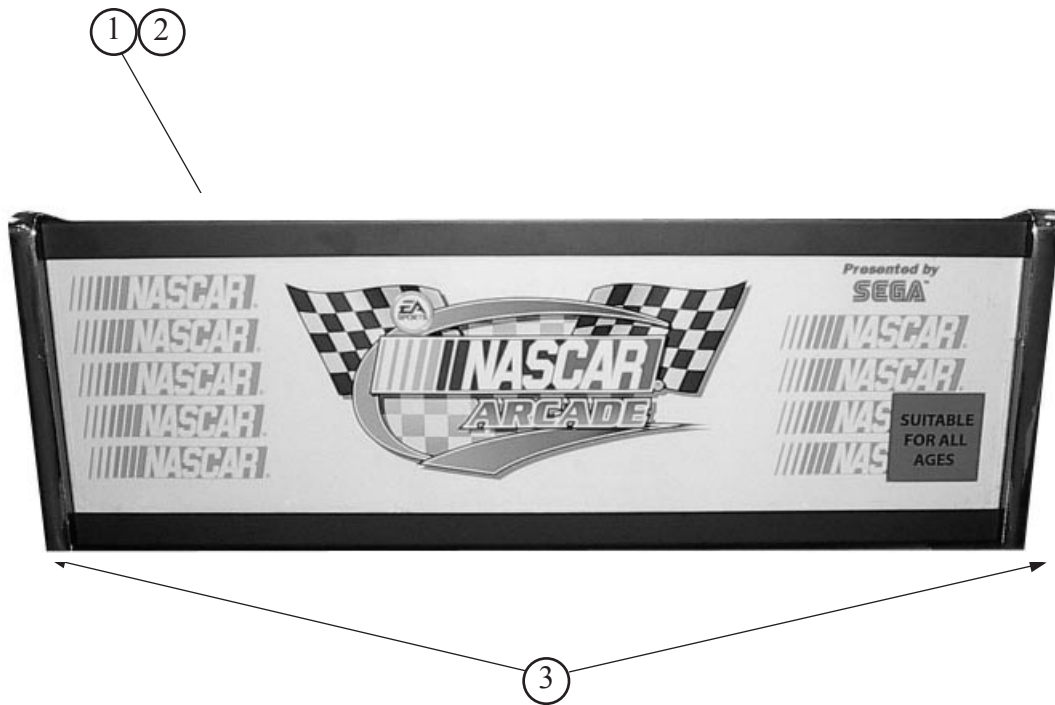

ITEM NO.	PART NO.	DESCRIPTION
1	999-1428	NASCAR MINI STANDARD MARQUEE
2	LOCAL PURCHASE	FLUORESCENT LAMP 24" F20T12CW
3	999-0963	SPEAKER 25W RMS 4 OHM

# ASSY MONITOR



ITEM NO.	PART NO.	DESCRIPTION
1	WELLS GARDNER	29" MONITOR MDL#WGM-2972-UOT-529K
2	LOCAL PURCHASE	MONITOR GLASS (29-7/8" X 22" X 3/16" TEMPER PROOF GLASS ONLY)
3	999-1068	BEZEL 27" MONITOR
4	999-1430	EPILEPSY WARNING LABEL

# ASSY CONTROL PANEL



ITEM NO.	PART NO.	DESCRIPTION
1	HAPP CONTROLS	WHEEL STEERING (HAPP MDL#50-2838-00-XV)
2	999-1069	PUSH BUTTON SMALL RND 57-2000-35
3	999-1070	PUSH BUTTON RECT. VLT 57-2000-62

# WHEEL STEERING - HAPP CONTROLS part no. 50-2838-00-XV

Tom Happ  
tom.happ@happcontrols.com  
Happ Controls  
106 Garlish Drive  
Elk Grove, IL. 60007  
Ph. 847-593-6161 ext. 107  
Fx. 847-956-2091

Visit our website <http://www.happcontrols.com>

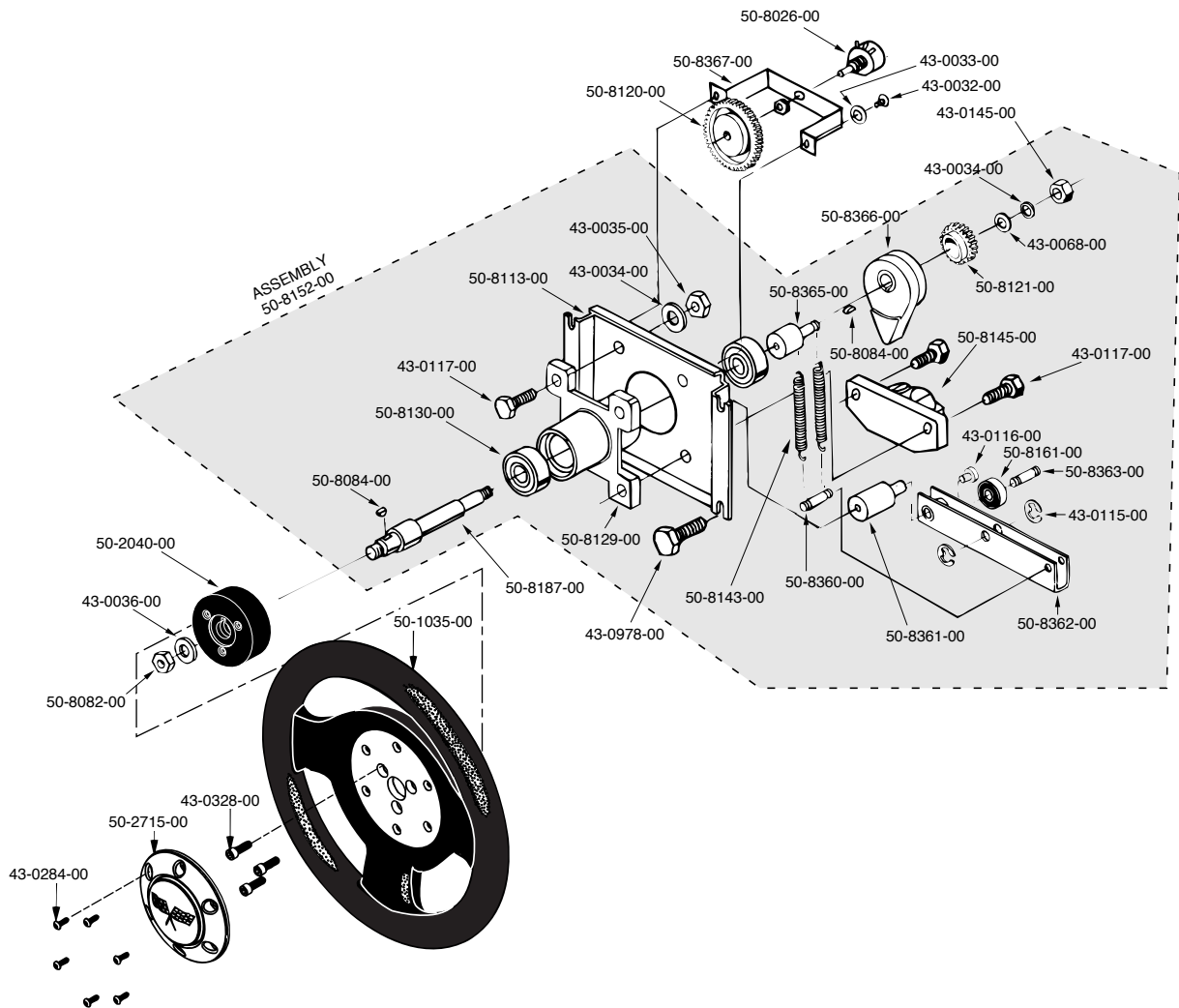



PEDAL DUAL - HAPP CONTROLS part no. 50-2661-00-XV

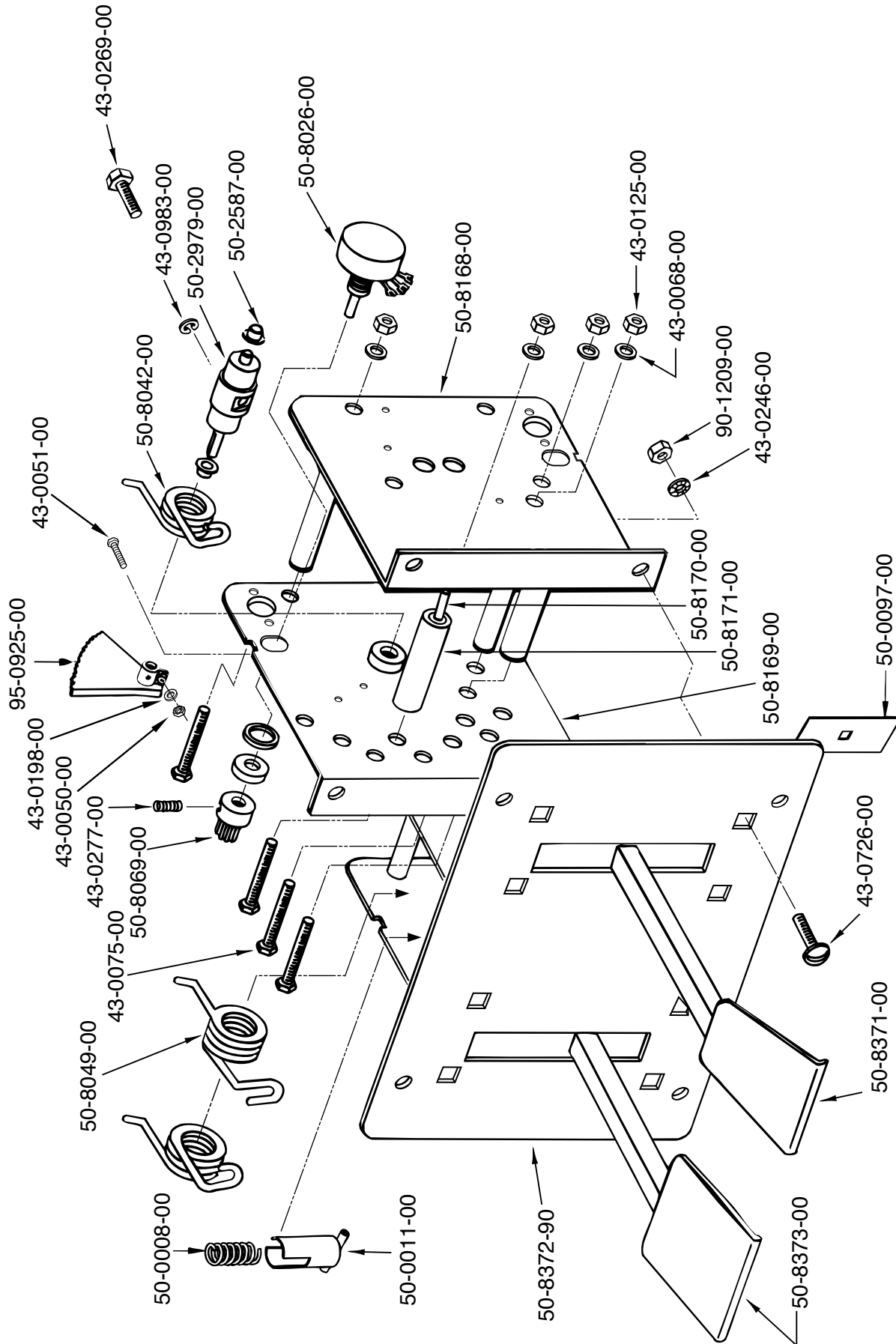

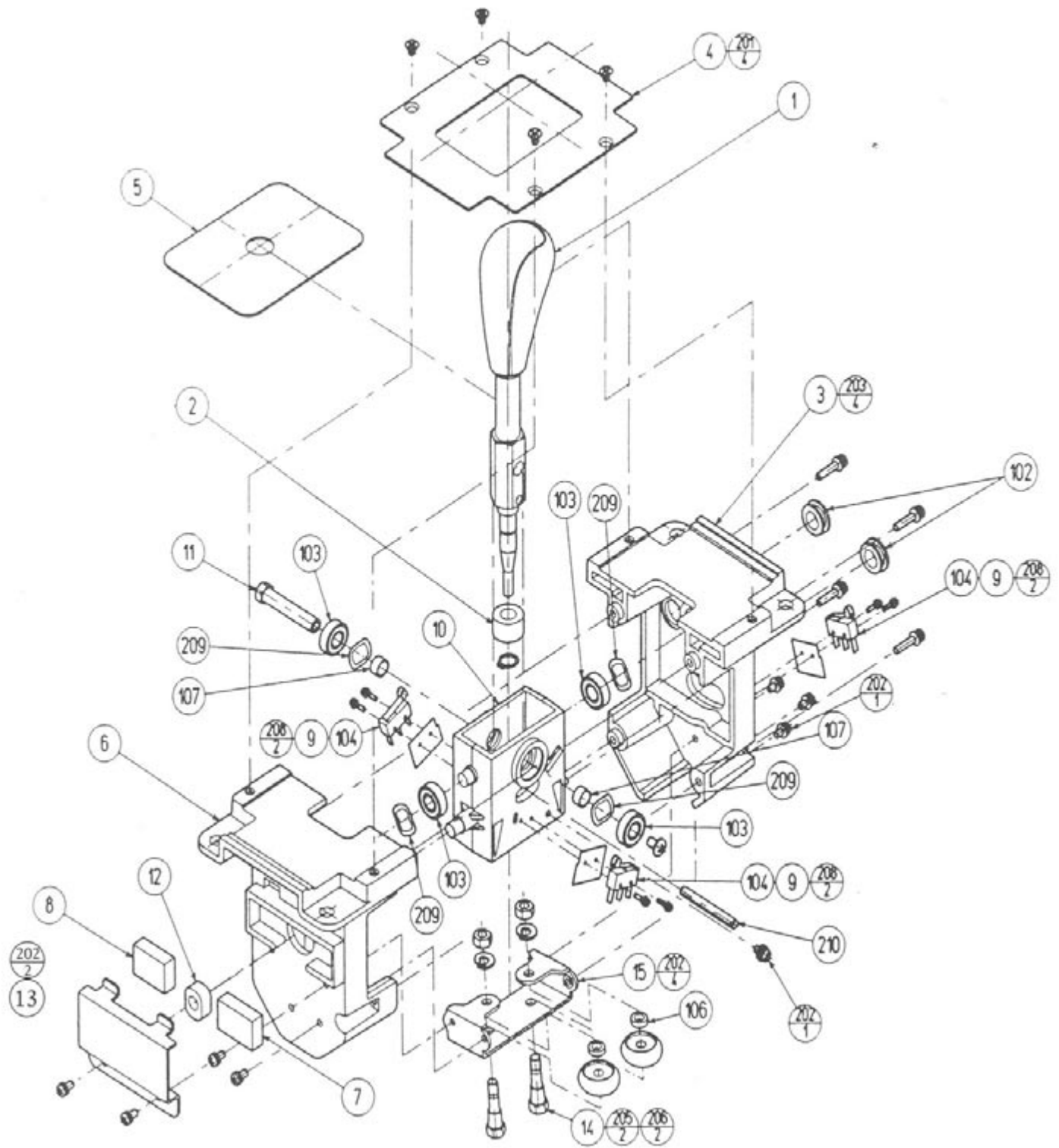

ASSY 4-SPEED SHIFTER (SPG5-2150)

(D-2/2)

ITEM NO.	PART NO.	DESCRIPTION
1	SPG-2151	SHIFT KNOB
2	SPG-2152	STOPPER RUBBER
3	SPG-2153	FRONT BASE
4	SPG-2154	SLIDE COVER
5	SPG-2155	SLIDE PLATE
6	SPG-2156	REAR BASE
7	SPG-2157	RUBBER BLOCK 45
8	SPG-2158	RUBBER BLOCK 65
9	SPG-2159	INSULATOR SHEET
10	SPG-2160	SHAFT CASE
11	SPG-2161	SHAFT BOLT
12	SPG-2162	CENTERING BLOCK
13	SPG-2163	RUBBER CASE
14	SPG-2164	ROLLER BOLT
15	SPG-2165	ROLLER SUPPORT
101	100-5252	BEARING ROLLER 25
102	100-5193	GROMMET 11
103	100-5242	BEARING FAI 8
104	509-5636	SW MICRO TYPE SS-5GL2T
105	601-0460	PLASTIC TIE BELT 100 MM
106	280-5306	SPACER FAI 6 X 30
107	280-5307	SPACER FAI 8 X 55
201	000-F00406	M SCR FH M4 X 6
202	000-P00410-W	M SCR PH W/FS M4 X 10
203	000-P00420-W	M SCR PH W/FS M4 X 20
205	050-H00600	HEX NUT M6
206	060-S00600	SPR WSHR M6
208	FAS-000033	M SCR PH W/FS M2.3 X 12
209	FAS-650008	WAVE WSHR 12.7-18.1 X 2.5
210	FAS-450006	SPR PIN WAVE STN 5 X 45
301	600-6445-45	WIRE HARN SHIFT MECHA
302	600-6872	WIRE HARN EARTH SHIFT MECHA

# TEST SWITCH

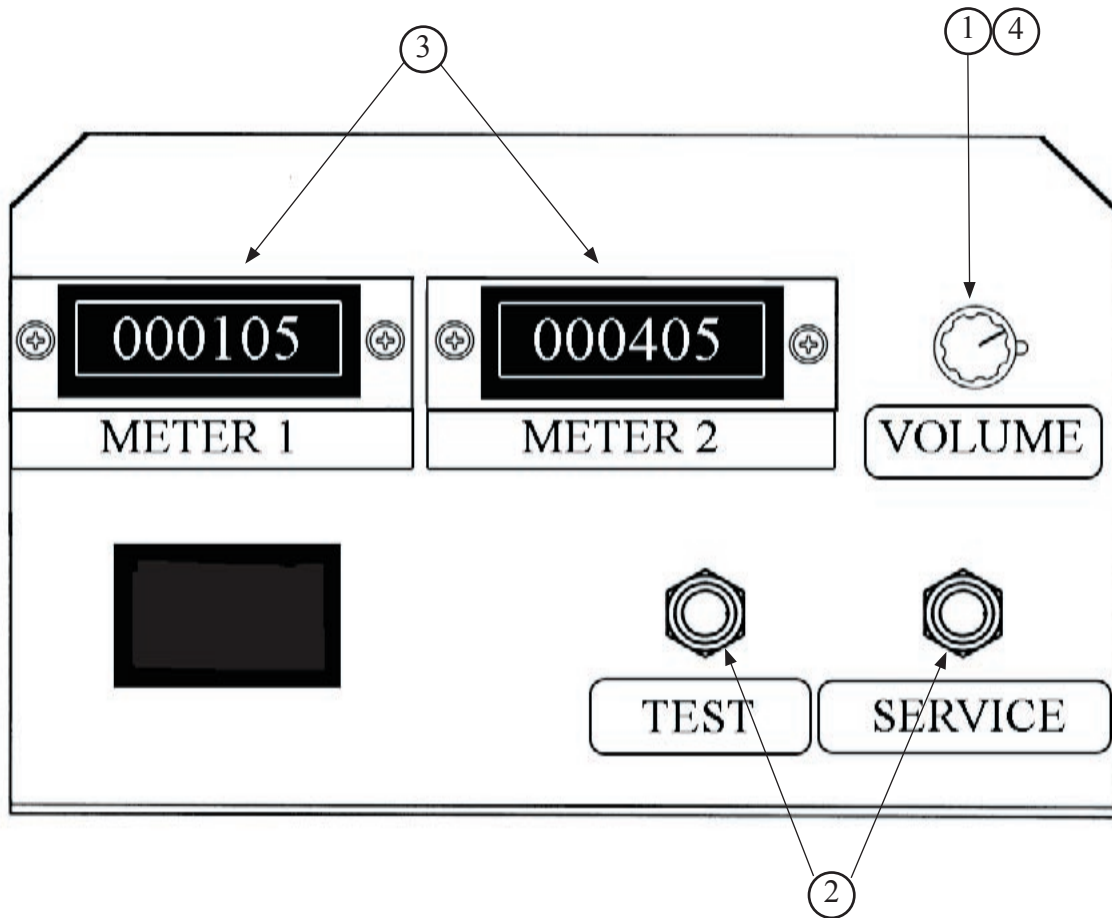

ITEM NO.	PART NO.	DESCRIPTION
1	LOCAL PURCHASE	VOLUME KNOB 1/4" - MOUSER#450-+2023
2	LOCAL PURCHASE	SWITCH TEST/SVC .5 AMP - MOUSER#104-0015
3	999-1050	COIN METER - IMPERIAL
4	999-1222	VOL CONT B-5K OHM (CONNECTED TO VOLUME KNOB)

# ASSY MAIN BD STD

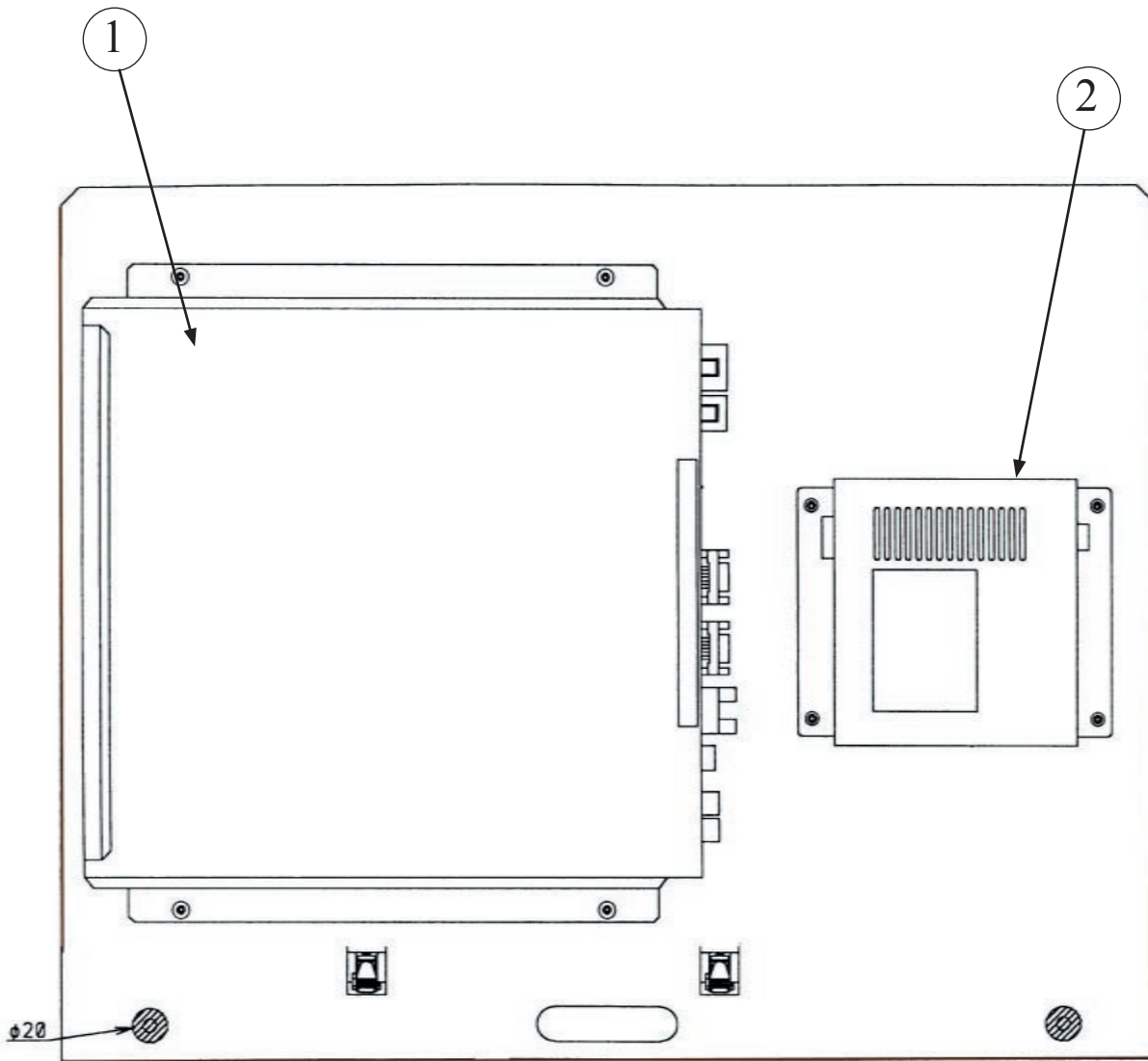

ITEM NO.	PART NO.	DESCRIPTION
1	NCR-4050	ASSY SHIELD CASE
2	400-5397-01	POWER SUPPLY

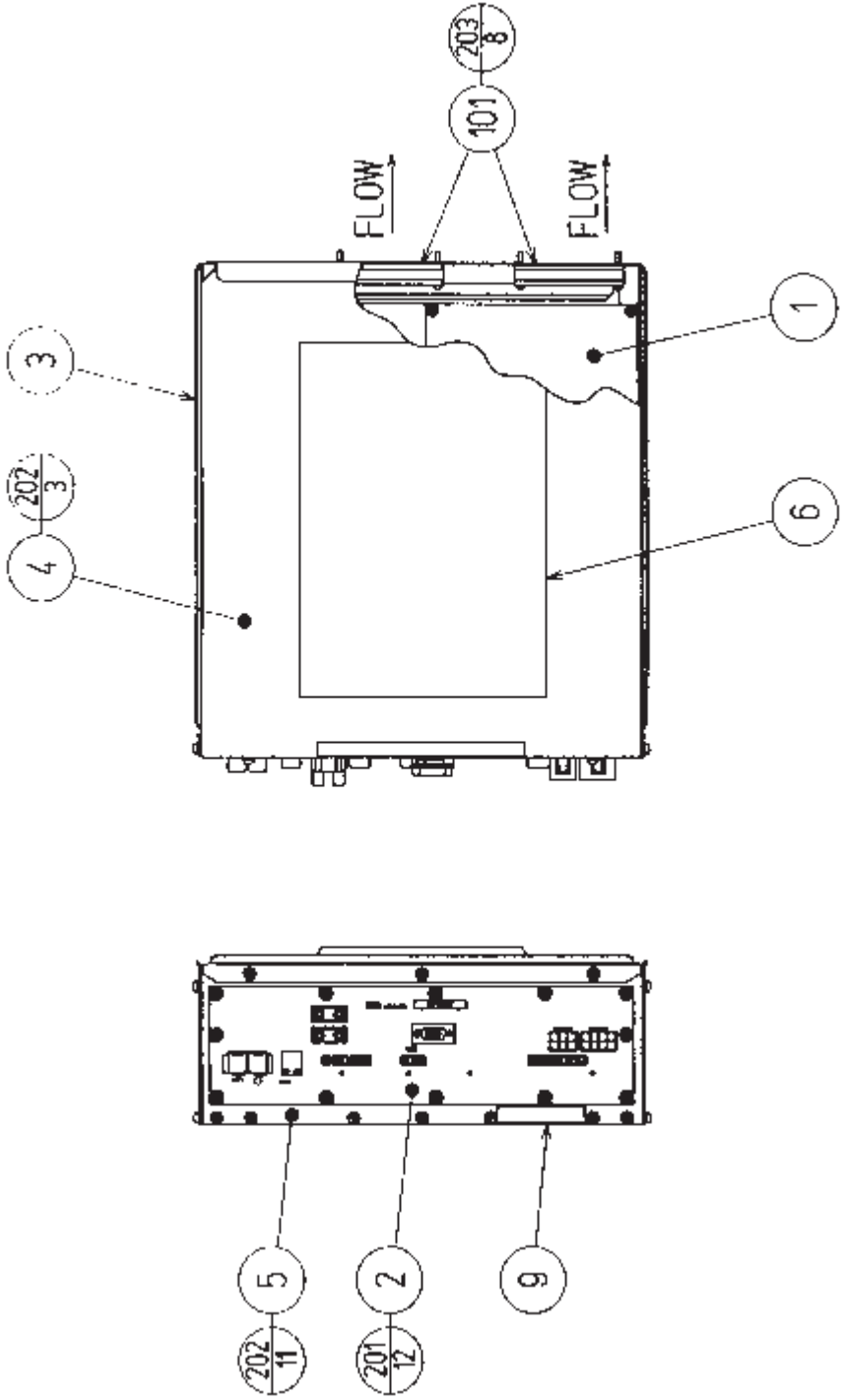

ASSY SHIELD CASE NCR (NCR-4050)

(D-2/2)

ITEM NO.	PART NO.	DESCRIPTION
1	833-14033	GAME BD NCR
2	839-1079-02	FLT BD SEGA HIKARU NCR
3	105-5378	SHIELD CASE FOR SEGA HIKARU
4	105-5379	SHIELD CASE LID FOR SEGAHIKARU
5	105-5381	FLT BD BRKT FOR SEGA HIKARU
6	421-9174	STICKER CAUTION ANTISTATIC
7	421-10023-AAB	STICKER BD SERIAL NUMBER AAB
8	421-10023-BBR	STICKER BD SERIAL NUMBER BBR
9	441-314033	STICKER 833-14033
10	601-10642	CARTON BOX SEGA HIKARU
101	260-0064	FAN MOTOR DC12V
102	280-5275-SR10	CORD CLAMP SR10
201	010-P00310-F	S-TITE SCR PH W/F M3 X 10
202	000-P00408-W	M SCR PH W/FS M4 X 8
203	000-P00325-W	M SCR PH W/FS M3 X 25

# ELECTRICAL ASSY

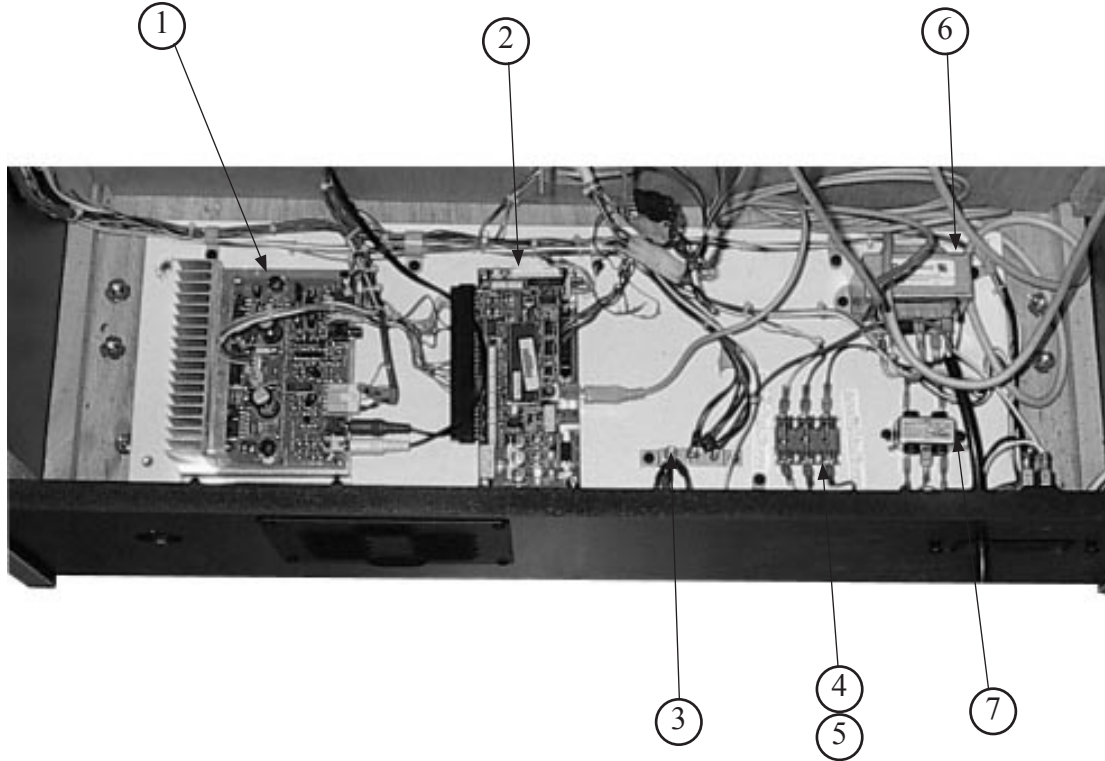

ITEM NO.	PART NO.	DESCRIPTION
1	838-13616	AUDIO POWER AMP 2CH
2	838-13683-02	JVS TO JAMMA I/O BOARD
3	999-1426	GROUNDING PLATE
4	GRAND	FUSE BLOCK 3 POS GP#0057-012-000
5	LOCAL PURCHASE	2-3AMP SB 250V 1-5AMP 250V
6	998-0146	TRANSFORMER MCI 4-06-8036
7	HAPP CONTROLS	LINE FILTER 6 AMP YUPEN YK06T1



## 22. WIRE COLOR CODE TABLE

THE WIRE COLOR CODE is as follow:

A	PINK
B	SKY BLUE
C	BROWN
D	PURPLE
E	LIGHT GREEN

Wires other than those of any of the above 5 single colors will be displayed by 2 alphanumeric characters.

1	RED
2	BLUE
3	YELLOW
4	GREEN
5	WHITE
7	ORANGE
8	BLACK
9	GRAY

If the right-hand side numeral of the code is 0, then the wire will be of a single color shown by the left-hand side numeral (see the above).

Note 1: If the right-hand side alphanumeric is not 0, that particular wire has a spiral color code. The left-hand side character shows the base color and the right-hand side one, the spiral color.

<Example> 51 ..... WHITE / RED

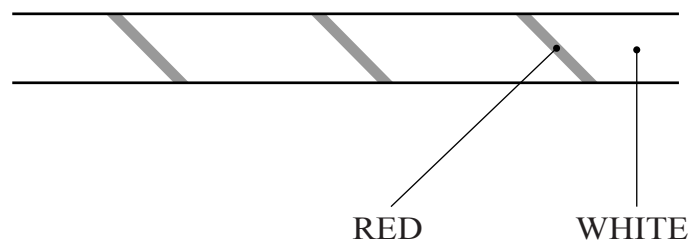

Note 2: The character following the wire color code indicates the size of the wire.

U:	AWG16
K:	AWG18
L:	AWG20
None:	AWG22

## **Warranty**

Your new Sega Product is covered for a period of 90 days from the date of shipment. This certifies that the Printed Circuit Boards, Power Supplies and Monitor are to be free of defects in workmanship or materials under normal operating conditions. This also certifies that all Interactive Control Assemblies are to be free from defects in workmanship and materials under normal operating conditions. No other product in this machine is hereby covered.

Sellers sole liability in the event a warranted part described above fails shall be, at its option, to replace or repair the defective part during the warranty period. For Warranty claims, contact your Sega Distributor.

Should the Seller determine, by inspection that the product was caused by Accident, Misuse, Neglect, Alteration, Improper Repair, Installation or Testing, the warranty offered will be null and void.

Under no circumstances is the Seller responsible for any loss of profits, loss of use, or other damages.

This shall be the exclusive written Warranty of the original purchaser expressed in lieu of all other warranties expressed or implied. Under no circumstance shall it extend beyond the period of time listed above.



**SEGA ENTERPRISES, INC. (USA)**

45133 Industrial Drive  
Fremont, CA 94538  
**(415) 701-6580** phone  
**(415) 701-6594** fax