

1ST PRINTING MAY '02

# SEGA



Standard Version

## Owner's Manual

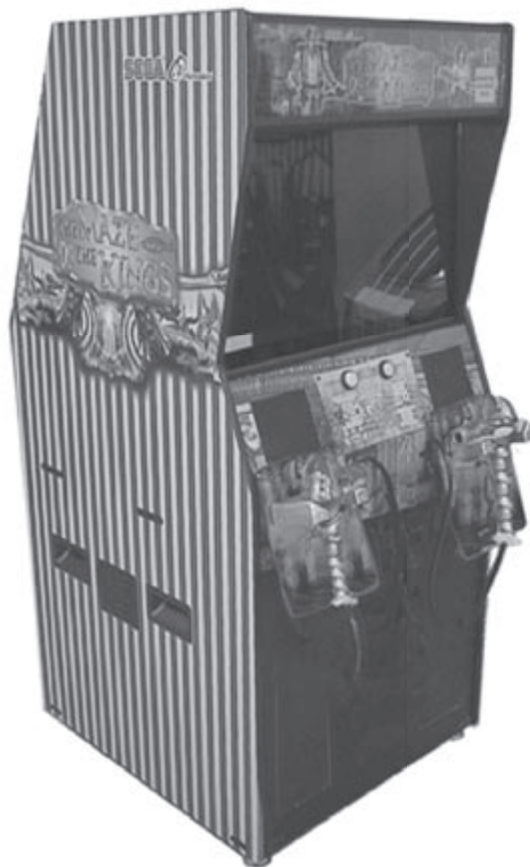

SEGA ENTERPRISES, INC. USA

MANUAL NO. 999-1441

# VISIT OUR WEBSITE!

Address: <http://seuservice.com/>

Live Home Page SegaService.com Apple Apple Support Apple Store **iTools** Mac OS X Microsoft MacTopia Office for Macintosh MEN

**SEGA SERVICE**

- what's new
- manuals
- bulletins
- assemblies
- Search
- Ask Dave

bulletin Sign-up  
register game

staff  
Darl's Office  
tech. service  
warranty policy

corporate info  
home page  
future technologies  
plug-ins  
non-framed page

Sega Enterprises Inc.,  
USA  
Service Department  
phone 415.701.6580  
fax 415.701.6594

## Need Parts for old Sega Games!

**15980** people have visited this page since 3/16/01

If you have any questions or comments about this site please E-Mail to [Darl.Davidson@seu.sega.com](mailto:Darl.Davidson@seu.sega.com)

Powered by **WEBSTAR SERVER SUITE 4**

[what's new](#)[manuals](#)[bulletins](#)[assemblies](#)[Search](#)[staff](#)[Darl's office](#)  
[technical service](#)[customer service](#)[corporate info](#)[plugins](#)[Non-framed page](#)

You will need the following items to view this page in its entirety.

**Get Acrobat Reader** **Microsoft Internet Explorer** **Microsoft Internet Explorer**

All Platforms Windows Macintosh

<http://itools.mac.com/WebObjects/Tools>

## BEFORE USING THE PRODUCT, BE SURE TO READ THE FOLLOWING:

To maintain the safety:

To ensure the safe usage of the product, be sure to read the following before using the product. The following instructions are intended for the users, operators and the personnel in charge of the operation of the product. After carefully reading and sufficiently understanding the warning displays and cautions, handle the product appropriately. Be sure to keep this manual nearby the product or elsewhere convenient for referring to it when necessary.

Herein, explanations which require special attention are enclosed with dual lines. Depending on the potentially hazardous degrees, the terms of WARNING, CAUTION, etc. are used. Be sure to understand the contents of the displays before reading the text.



Indicates that mishandling the product by disregarding this warning will cause a potentially hazardous situation which can result in death or serious injury.



Indicates that mishandling the product by disregarding this caution will cause a slight hazardous situation which can result in personal injury and or material damage.

### For the safe usage of the product, the following pictographs are used:



Indicates “HANDLE WITH CARE.” In order to protect the human body an equipment, this display is attached to places where the Owner’s Manual and or Service Manual should be referred to.

- **Perform work in accordance with the instructions herein stated.**  
Instructions for work are explained by paying attention to the aspect of accident prevention. Failing to perform work as per the instructions can cause accidents. In the case where only those who have technical expertise should perform the work to avoid hazardous situation, the instructions herein state that the serviceman should perform such work.
- **Be sure to turn off power before working on the machine.**  
To prevent electric shock, be sure to turn off power before starting the work in which the worker touches the interior of the product. If the work is to be performed in the power-on status, the Instruction Manual herein always states to that effect.
- **Be sure to ground the Earth Terminal** (this, however, is not required in the case where a power cord with earth is used).  
This product is equipped with the Earth Terminal. When installing the product, Connect the Earth Terminal to the “accurately grounded indoor earth terminal” by using an earth wire. Unless the product is grounded appropriately, the user can be subject to electric shock. After performing repair, etc. for the Control equipment, ensure that the Earth Wire is firmly connected to the Control equipment.
- **Ensure that the Power Supply used is equipped with an Earth Leakage Breaker.**  
This product does not incorporate the Earth Leakage Breaker. Using a power supply which is not equipped with the Earth Leakage Breaker can cause a fire when earth leakage occurs.
- **Be sure to use fuses which meet the specified rating.** (only for the machines which use fuses).  
Using fuses exceeding the specified rating can cause a fire and electric shock.

- **Specification changes (removal of equipment, conversion and addition) not designated by SEGA are not allowed.**  
The parts of the product include warning labels for safety, covers for personal protection, etc. It is very hazardous to operate the product by removing parts and or modifying the circuits. Should doors, lids and protective parts be damaged or lost, refrain from operating the product, and contact where the product was purchased from or the office herein stated. SEGA shall not be held responsible for any accidents, compensation for damage to a third party, resulting from the specifications not designated by SEGA.
  - **Ensure that the product meets the requirements of appropriate Electrical Specifications.**  
Before installing the product, check for Electrical Specifications. SEGA products have a nameplate on which Electrical Specifications are described. Ensure that the product is compatible with the power supply voltage and frequency requirements of the location. Using any Electrical Specifications different from the designated Specifications can cause a fire and electric shock.
  - **Install and operate the product in places where appropriate lighting is available, allowing warning labels to be clearly read.**  
To ensure safety for the customers, labels and printed instructions describing potentially hazardous situation are applied to places where accidents can be caused. Ensure that where the product is operated has sufficient lighting allowing the warnings to be read. If any label is peeled off, apply it again immediately. Please place an order with where the product was purchased from or the office herein stated.
  - **When handling the Monitor, be very careful. (Applies only to the product w/monitor.)**  
Some of the monitor (TV) parts are subject to high tension voltage. Even after running off power, some portions are still subject to high tension voltage sometimes. Monitor repair and replacement should be performed only by those technical personnel who have knowledge of electricity and technical expertise.
  - **Be sure to adjust the monitor (projector) properly. (Applies only to the product w/monitor.)**  
Do not operate the product leaving on-screen flickering or blurring as it is. Using the product with the monitor not properly adjusted may cause dizziness or a headache to an operator, a player, or the customers.
  - **When transporting or reselling this product, be sure to attach this manual to the product.**  
In the case where commercially available monitors and printers are used in this product, only the contents relating to this product are explained herein. Some commercially available equipment has functions and reactions not stated in this manual. Read this manual together with the specific Instruction Manual of such equipment.
- Descriptions herein contained may be subject to improvement changes without notice.
  - The contents described herein are fully prepared with due care. However, should any question arise or errors be found, please contact SEGA.

#### **INSPECTIONS IMMEDIATELY AFTER TRANSPORTING THE PRODUCT TO THE LOCATION.**

Normally, at the time of shipment, SEGA products are in a status allowing for usage immediately after transporting to the location. Nevertheless, an irregular situation may occur during transportation. Before turning on power, check the following points to ensure that the product has been transported in a satisfactory status.

- Are there any dented portions or defects (cuts, etc.) on the external surfaces of the cabinet?
- Are Casters and Adjusters, damaged?
- Do the power supply voltage and frequency requirements meet with those of the location?
- Are all wiring connectors correctly and securely connected? Unless connected in the correct direction, connector connections can not be made accurately. Do not insert connectors forcibly.
- Do power cords have cuts and dents?
- Do the fuses used meet specified rating? Is the Circuit Protector in an energized status?
- Are all accessories available?
- Can all Doors and Lids be opened with the Accessory keys? Can Doors and Lids be firmly closed?

---

---

## TABLE OF CONTENTS

---

---

BEFORE USING THE PRODUCT, BE SURE TO READ THE FOLLOWING:

TABLE OF CONTENTS

INTRODUCTION OF THE OWNER'S MANUAL

1. HANDLING PRECAUTIONS .....	1
2. PRECAUTIONS CONCERNING INSTALLATION LOCATION .....	2 - 3
3. OPERATION .....	4 - 7
4. NAME OF PARTS .....	8
5. ACCESSORIES .....	9 - 13
6. ASSEMBLING AND INSTALLATION .....	14 - 28
7. PRECAUTIONS TO BE HEDED WHEN MOVING THE MACHINE .....	29
8. CONTENTS OF GAME .....	30 - 39
9. EXPLANATION OF TEST AND DATA DISPLAY .....	40 - 53
9 - 1 SWITCH UNIT AND COIN METER .....	41
9 - 2 SYSTEM TEST MODE .....	42
9 - 3 GAME TEST MODE .....	43 - 53
10. CONTROLLER .....	54 - 55
11. MONITOR .....	56 - 60
11 - 1 CAUTIONS AND WARNINGS CONCERNING THE SAFETY FOR HANDLING THE MONITORS .....	56 - 58
11 - 2 CAUTIONS TO BE HEDED WHEN CLEANING THE CRT SURFACES .....	58
11 - 3 ADJUSTMENT METHOD .....	59 - 60
12. COIN SELECTOR .....	61 - 64
13. REPLACING THE FLOURESCENT LAMP, AND LAMPS .....	65 - 66
14. PERIODIC INSPECTION TABLE .....	67 - 68
15. TROUBLESHOOTING .....	69 - 71
16. GAME BOARD .....	72 - 76
16 - 1 REMOVING THE GAME BOARD .....	72 - 75
16 - 2 COMPOSITION OF GAME BOARD .....	76
17. DESIGN RELATED PARTS .....	77 - 78
18. PARTS LIST .....	79 - 100
19. WIRE COLOR CODE TABLE .....	101
20. WIRING DIAGRAM .....	XXX

## SPECIFICATIONS

Installation Space	: 31.5 in.(W) X 39.3 in(D)
Height	: 80.5 in
Weight	: Approx. 396.8 lbs.
Power, maximum current	: 285 W 3.32 A (AC 110V 50 Hz AREA) 280 W 3.20 A (AC 110V 60 Hz AREA) 280 W 2.95 A (AC 120V 60 Hz AREA) 290 W 1.63 A (AC 220V 50 Hz AREA) 290 W 1.60 A (AC 220V 60 Hz AREA) 285 W 1.57 A (AC 230V 50 Hz AREA) 285 W 1.55 A (AC 230V 60 Hz AREA) 290 W 1.51 A (AC 240V 50 Hz AREA) 295 W 1.50 A (AC 240V 60 Hz AREA)
For TAIWAN	
Power, current	: 278 W 3.20 A (MAX.) 170 W 1.96 A (MIN.)
MONITOR	: 29" SANWA TYPE COLOR MONITOR

## INTRODUCTION OF THE OWNERS MANUAL

This Owner's Manual is intended to provide detailed descriptions together with all the necessary information covering the general operation of electronic assemblies, electromechanicals, servicing control, spare parts, etc. as regards the product,  
**MAZE OF KINGS STANDARD TYPE.**

This manual is intended for the owners, personnel and managers in charge of operation of the product. Operate the product after carefully reading and sufficiently understanding the instructions. If the product fails to function satisfactorily, non-technical personnel should under no circumstances touch the internal system. Please contact where the product was purchased from.

Use of this product is unlikely to cause physical injuries or damages to property. However, where special attention is required this is indicated by a thick line, the word "IMPORTANT" and its sign in this manual.



**IMPORTANT!**

Indicates that mishandling the product by disregarding this display can cause the product's intrinsic performance not to be obtained, resulting in malfunctioning.

SEGA ENTERPRISES, INC. (U.S.A.)/CUSTOMER SERVICE  
45133 Industrial Drive, Fremont, California 94538, U.S.A.  
Phone : (415) 701-6580  
Fax : (415) 701-6594

## DEFINITION OF LOCATION MAINTENANCE MAN AND SERVICEMAN



Non-technical personnel who do not have technical knowledge and expertise should refrain from performing such work that this manual requires the location's maintenance man or a serviceman to carry out, or work which is not explained in this manual. Failing to comply with this instruction can cause a severe accident such as electric shock.

Ensure that parts replacement, servicing & inspections, and troubleshooting are performed by the location's maintenance man or the serviceman. It is instructed herein that particularly hazardous work should be performed by the serviceman who has technical expertise and knowledge.

The location's maintenance man and serviceman are herein defined as follows:

### **"Location's Maintenance Man" :**

Those who have experience in the maintenance of amusement equipment and vending machines, etc., and also participate in the servicing and control of the equipment through such routine work as equipment assembly and installation, servicing and inspections, replacement of units and consumables, etc. within the Amusement Facilities and or locations under the management of the Owner and Owner's Operators of the product.

### **Activities of Location's Maintenance Man :**

Assembly & installation, servicing & inspections, and replacement of units & consumables as regards amusement equipment, vending machines, etc.

### **Serviceman :**

Those who participate in the designing, manufacturing, inspections and maintenance service of the equipment at an amusement equipment manufacturer.

Those who have technical expertise equivalent to that of technical high school graduates as regards electricity, electronics and or mechanical engineering, and daily take part in the servicing & control and repair of amusement equipment.

### **Serviceman's Activities :**

Assembly & installation and repair & adjustments of electrical, electronic and mechanical parts of amusement equipment and vending machines.

**LISTED**



**5K92**

**AMUSEMENT MACHINE**

# 1. HANDLING PRECAUTIONS

When installing or inspecting the machine, be very careful of the following points and pay attention to ensure that the player can enjoy the game safely.

Non-compliance with the following points or inappropriate handling running counter to the cautionary matters herein stated can cause personal injury or damage to the machine.



- Before performing work, be sure to turn power off. Performing the work without turning power off can cause an electric shock or short circuit. In the case work should be performed in the status of power on, this manual always states to that effect.
- To avoid electric shock or short circuit, do not plug in or unplug quickly.
- To avoid electric shock, do not plug in or unplug with a wet hand.
- Do not expose Power Cords and Earth Wires on the surface, (floor, passage, etc.). If exposed, the Power Cords and Earth Wires are susceptible to damage. Damaged cords and wires can cause electric shock or short circuit.
- To avoid causing a fire or electric shock, do not put things on or damage Power Cords.
- When or after installing the product, do not unnecessarily pull the Power Cord. If damaged, the Power Cord can cause a fire or electric shock.
- In case the Power Cord is damaged, ask for replacement through where the product was purchased from or the office herein stated. Using the cord as is damaged can cause fire, electric shock or leakage.
- Be sure to perform grounding appropriately. Inappropriate grounding can cause an electric shock.
- Be sure to use fuses meeting specified rating. Using fuses exceeding the specified rating can cause a fire or electric shock.
- Completely make connector connections for IC BD and others. Insufficient insertion can cause an electric shock.
- Specification changes, removal of equipment, conversion and/or addition, not designated by SEGA are not permitted.
- Failure to observe this may cause a fire or an electric shock. Non-compliance with this instruction can have a bad influence upon physical conditions of the players or the lookers-on, or result in injury during play.
- SEGA shall not be held responsible for damage, compensation for damage to a third party, caused by specification changes not designated by SEGA.
- Be sure to perform periodic maintenance inspections herein stated.



- For the IC board circuit inspections, only the logic tester is allowed. The use of a multiple-purpose tester is not permitted, so be careful in this regard.
- The Projector is employed for this machine. The Projector's screen is susceptible to damage, therefore, be very careful when cleaning the screen. For details, refer to PROJECTOR.



## 2. PRECAUTIONS CONCERNING INSTALLATION LOCATION



This product is an indoor game machine. Do not install it outside. Even indoors, avoid installing in places mentioned below so as not to cause a fire, electric shock, injury and or malfunctioning.

- Places subject to rain or water leakage, or places subject to high humidity in the proximity of an indoor swimming pool and or shower, etc.
- Places subject to direct sunlight, or places subject to high temperatures in the proximity of heating units, etc.
- Places filled with inflammable gas or vicinity of highly inflammable/volatile chemicals or hazardous matter.
- Dusty places.
- Sloped surfaces.
- Places subject to any type of violent impact.
- Vicinity of anti-disaster facilities such as fire exits and fire extinguishers.
- The operating (ambient) temperature range is from 5° Celsius to 40° Celsius.
- Only in the case a projector is employed, the temperature range is from 5° Celsius to 30° Celsius.

### LIMITATIONS OF USAGE REQUIREMENTS



- Be sure to check the Electrical Specifications.  
Ensure that this product is compatible with the location's power supply, voltage and frequency requirements.
- A plate describing Electrical Specifications is attached to the product.
- Non-compliance with the Electrical Specifications can cause a fire and electric shock.
- This product requires the Breaker and Earth Mechanisms as part of the location facilities. Using them in a manner not independent can cause a fire and electric shock.
- Ensure that the indoor wiring for the power supply is rated at 15A or higher (AC single phase 100 ~ 120V area), and 7A or higher (AC 220 ~ 240V area).
- Non-compliance with the Electrical Specifications can cause a fire and electric shock.
- Be sure to independently use the power supply equipped with the Earth Leakage Breaker. Using a power supply without the Earth Leakage Breaker can cause an outbreak of fire when earth leakage occurs.
- Putting many loads on one electrical outlet can cause generation of heat and a fire resulting from overload.
- When using an extension cord, ensure that the cord is rated at 15A or higher (AC 100 ~ 120V area) and 7A or higher (AC 220 ~ 240V area). Using a cord rated lower than the specified rating can cause a fire and electric shock.

OPERATION AREA



- For the operation of this machine, secure a minimum area of 55 inches (W) X 71 inches (D). In order to prevent injury resulting from the falling down accident during game play, be sure to secure the minimum area for operation.
- Be sure to provide sufficient space so as to allow this product's ventilation fan to function efficiently. To avoid machine malfunctioning and a fire, do not place any obstacles near the ventilation opening.
- SEGA shall not be held responsible for damage, compensation for damage to a third party, resulting from the failure to observe this instruction.



For transporting the machine into the location's building, the minimum necessary dimensions of the opening (of doors, etc.) are 35 inches (W) and 79 inches (H).

Electric current consumption

MAY. 3.32 A (AC 110V 50 Hz)
MAY. 3.20 A (AC 110V 60 Hz)
MAY. 2.95 A (AC 120V 60 Hz)
MAY. 1.63 A (AC 220V 50 Hz)
MAY. 1.60 A (AC 220V 60 Hz)
MAY. 1.57 A (AC 230V 50 Hz)
MAY. 1.55 A (AC 230V 60 Hz)
MAY. 1.51 A (AC 240V 50 Hz)
MAY. 1.50 A (AC 240V 60 Hz)

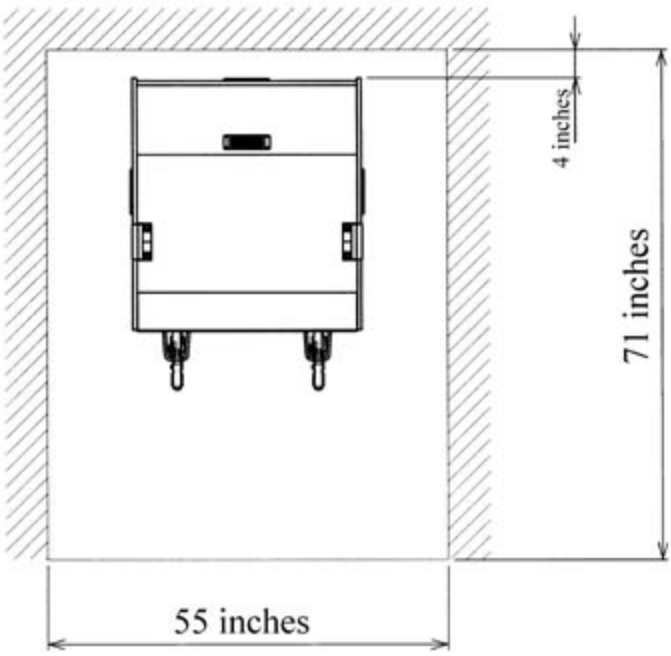

FIG. 2

### 3. OPERATION

#### PRECAUTIONS TO BE HEEDED BEFORE STARTING THE OPERATION

To avoid injury and trouble, be sure to constantly give careful attention to the behavior and manner of the visitors and players.



In order to avoid accidents, check the following before starting the operation:

- To ensure maximum safety for the players and the customers, ensure that where the product is operated has sufficient lighting to allow any warnings to be read. Operation under insufficient lighting can cause bodily contact with each other, hitting accident, and or trouble between customers.
- Be sure to perform appropriate adjustment of the monitor (projector). For operation of this machine, do not leave monitor's flickering or deviation as is. Failure to observe this can have a bad influence upon the players' or the customers' physical conditions.
- It is suggested to ensure a space allowing the players who feel sick while playing the game to take a rest.
- Check if all of the adjusters are in contact with the surface. If they are not, the Cabinet can move and cause an accident.

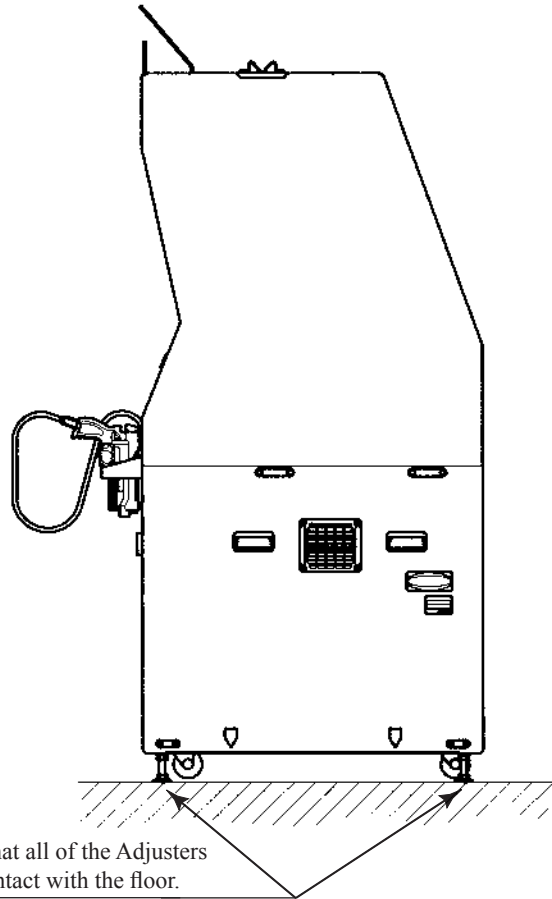

\* Guns are different in actual game.



- Do not put any heavy item on this product. Placing any heavy item on the product can cause a falling down accident or parts damage.
- Do not climb on the product. Climbing on the product can cause falling down accidents. To check the top portion of the product, use a step.
- To avoid electric shock, check to see if door & cover parts are damaged or omitted.
- To avoid electric shock, short circuit and or parts damage, do not put the following items on or in the periphery of the product.
- Flower vases, flowerpots, cups, water tanks, cosmetics, and receptacles/containers/vessels containing chemicals and water.



To avoid injury, be sure to provide sufficient space by considering the potentially crowded situation at the installation location. Insufficient installation space can cause making bodily contact with each other, hitting accidents, and or trouble between customers.



Players with bare hands directly hold the guns. For operation, it is recommended that wet towels (paper towels) be provided.

PRECAUTIONS TO BE HEEDED DURING OPERATION (PAYING ATTENTION TO CUSTOMERS)

To avoid injury and trouble, be sure to constantly give careful attention to the behavior and manner of the visitors and players.



- To avoid injury and accidents, those who fall under the following categories are not allowed to play the game.
  - Those who need assistance such as the use of an apparatus when walking.
  - Those who have high blood pressure or a heart problem.
  - Those who have experienced muscle convulsion or loss of consciousness when playing video game, etc.
  - Those who have a trouble in the neck and or spinal cord.
  - Intoxicated persons.
  - Pregnant women or those who are in the likelihood of pregnancy.
  - Persons susceptible to motion sickness.
  - Persons whose act runs counter to the product's warning displays.
- A player who has never been adversely affected by light stimulus might experience dizziness or headache depending on his physical condition when playing the game. Especially, small children can be subject to those conditions. Caution guardians of small children to keep watch on their children during play.
- Instruct those who feel sick during play to have a medical examination. To avoid injury resulting from falling down and electric shock due to spilled drinks, instruct the player not to place heavy items or drinks on the product.
- To avoid electric shock and short circuit, do not allow customers to put hands and fingers or extraneous matter in the openings of the product or small openings in or around the doors.
- To avoid falling down and injury resulting from falling down, immediately stop the customer's leaning against or climbing on the product, etc.
- To avoid electric shock and short circuit, do not allow the customers to unplug the power plug without a justifiable reason.



Immediately stop such violent acts as hitting and kicking the product. Such violent acts can cause parts damage or falling down, resulting in injury due to fragments and falling down.



**WARNING: HAZARD TO EPILEPTICS.**

- A very small portion of the population has a condition which may cause them to experience epileptic seizures or have momentary loss of consciousness when viewing certain kinds of flashing lights or patterns that are present in our daily environment. These persons may experience seizures while watching some kinds of television pictures or playing certain video games. People who have not had any previous seizures may nonetheless have an undetected epileptic condition.
- If you or anyone in your family has experienced symptoms linked to an epileptic condition (e.g., seizures or loss of awareness), immediately consult your physician before using any video games.
- We recommend that parents observe their children while they play video games. If you or your child experience the following symptoms: dizziness, altered vision, eye or muscle twitching, involuntary movements, loss of awareness, disorientation, or convulsions, **DISCONTINUE USE IMMEDIATELY** and consult your physician.

# 4. NAME OF PARTS

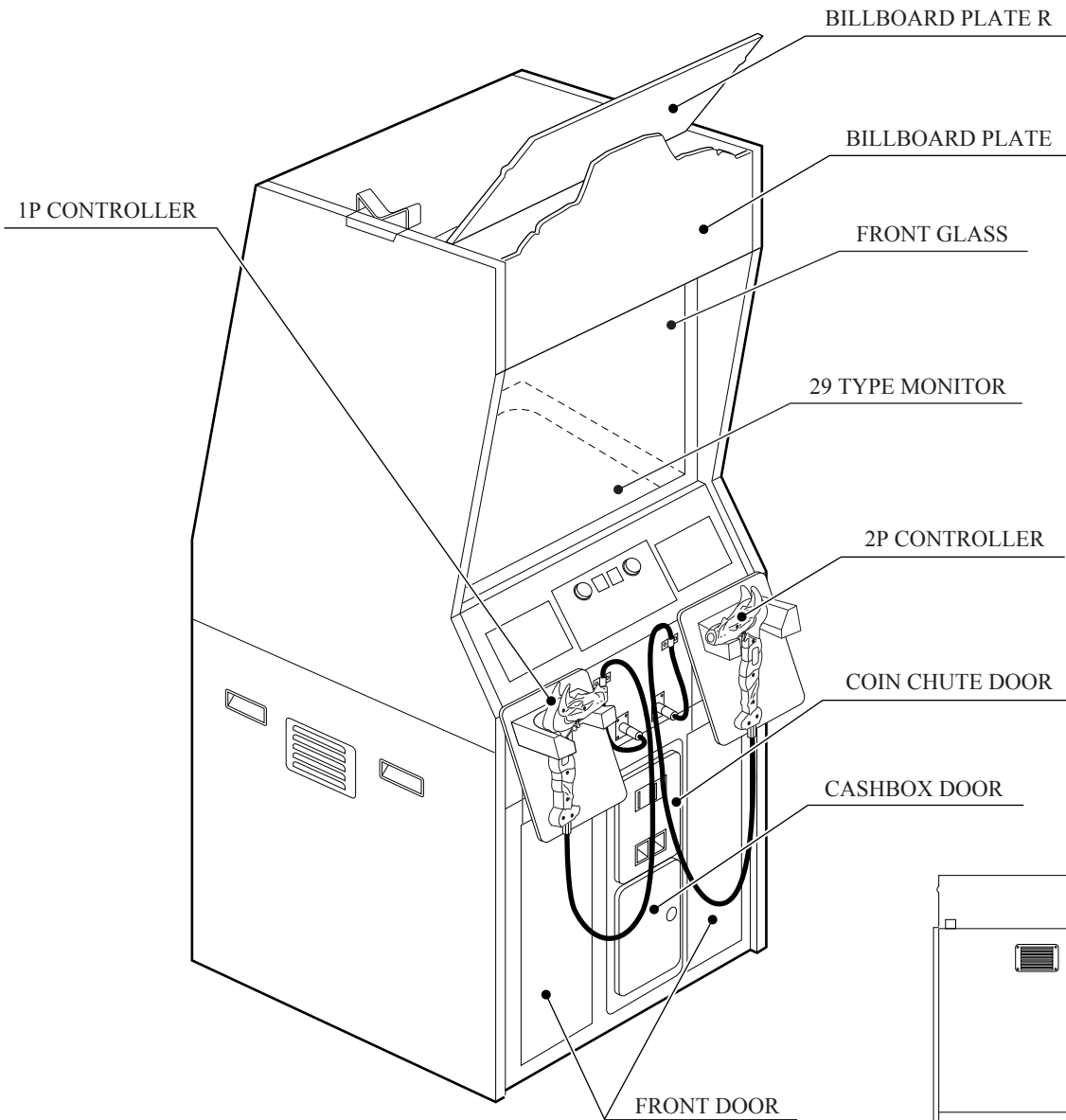

FIG. 4 a OVERVIEW \*

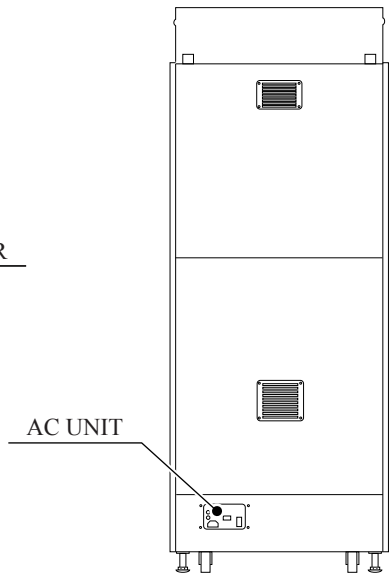

FIG. 4 b REAR VIEW

TABLE 4

	Width	X	Length	X	Height	Weight
CABINET	32 inches	X	39.5 inches	X	75 inches	396 lbs
When assembled	32 inches	X	39.5 inches	X	75 inches	396 lbs

# 5. ACCESSORIES

When transporting the machine, make sure that the following parts are supplied.

TABLE 5 ACCESSORIES

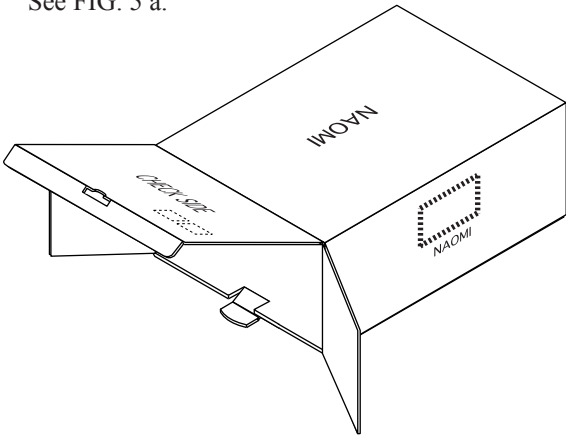
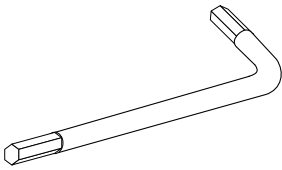
<p>DESCRIPTION Part No. (Qty.)</p>	<p>OWNERS MANUAL 999 - 1441 (1)</p>	<p>KEY MASTER 9301A (2)</p>	<p>KEY (2)</p>
<p>Note</p> <p>Figures</p> <p>If Part No. has no description, the Number has not been registered or can not be registered. Such a part may not be obtainable even if the customer desires to purchase it. Therefore, ensure that the part is in safekeeping with you.</p>		<p>For opening/closing the doors</p>	<p>For the CASHBOX DOOR</p>
<p>GD-ROM SERVICE MANUAL ENG 420-6620-01 (1)</p> <p>INSTRUCTION MANUAL FOR THE GAME BOARD AND GD-ROM</p>		<p>CARTON BOX 601-10532 (1)</p> <p>Used for transporting the Game Board. See FIG. 5 a.</p>	
<p>TAMPER PROOF WRENCH M4 540-0006-01 (1)</p> <p>TOOL</p>			
			



## HOW TO USE THE CARTON BOX



When requesting for the replacement/repair of this product's Game Board (NAO-MI BOARD), follow the instructions below. Transporting the Game Board in an undesignated status is unacceptable. An erroneous handling can cause parts damage.

- Put the Game Board in the Carton Box together with the Shield Case. Do not unnecessarily disassemble nor remove parts.
- By paying careful attention to the following Figure and the direction shown by on-Carton-Box printing, put the Shield Case in the Carton Box.
- When putting the Shield Case in the Carton Box, do not remove Leg Brackets.
- The projected portions of the packing material is intended for cushioning. Therefore, do not bend the projected portions.
- Do not remove the DIMM board without fail.

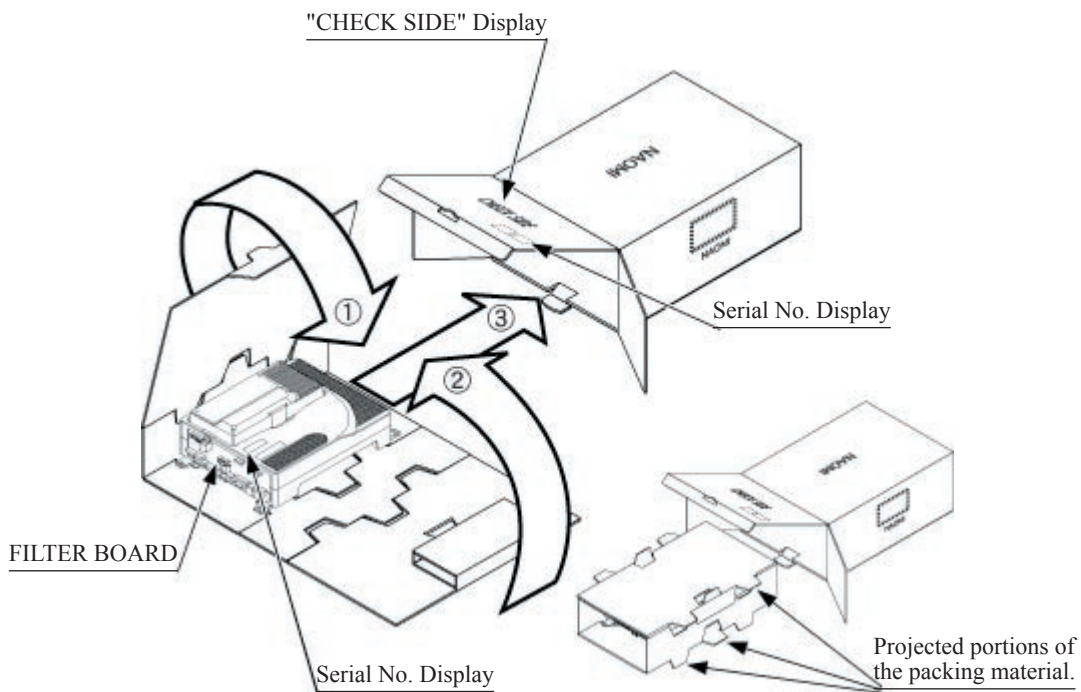

FIG. 5 a

Fold the packing material in the sequential order of the numbers shown in the Figure, enfold the Shield Case and put it in the Carton Box. Positioning the Shield Case upside down or packing in the manner different from what is shown in this Figure can cause the Game Board and other parts to be damaged.

The following Table 5b lists the parts that had been separately packed when the product was shipped from the factory but are necessary when you use the product. These parts will be mounted on the product when installing and assembling it.

TABLE 5 b

GD DRIVE BRACKET

105-5435 (1)

To be mounted on the GD-ROM drive.  
see [3](#) of Section 6.

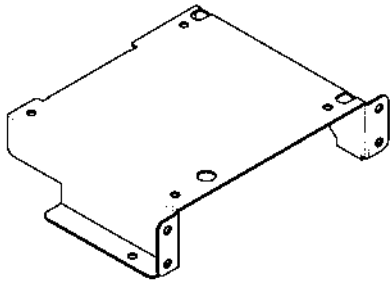

GD-ROM

610-0625-0022 (1)

KEY CHIP

253-5508-0333 (1)

Game software media contained in a plastic case.  
see [3](#) of Section 6.

NOTE: A packing/shipping method of this product is specific with this CONFIDENTIAL MISSION U/R TYPE product. It may be different from, therefore, the descriptions in the GD-ROM Service Manual.

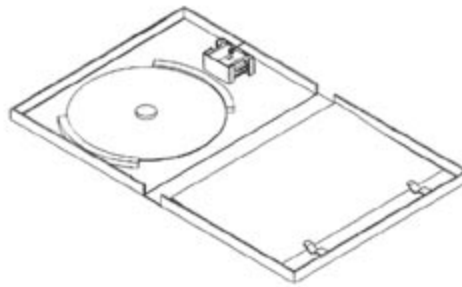

AC Cable (Power Cord)

Used for installation, see [4](#) of Section 6.

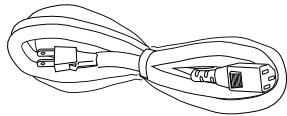

The following Table 5c lists the parts that are separately marketed but are necessary when booting this product's software. When having unpacked the shipping crate, make sure that all the parts in this Table 5C are in the crate. If not so, contact where you have obtained the product.

TABLE 5 c (XKT-0833 : GD-ROM DRIVE KIT)

GD-ROM DRIVE  
610-0617 (1)

Device that loads the software in a GD-ROM disk.  
see [3](#) of Section 6.

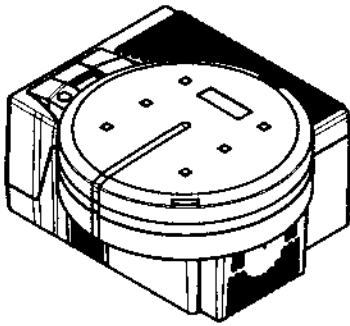

GD-ROM DRIVE CARTON BOX  
(1)

Used for transporting the GD-ROM DRIVE.  
See FIG. 5 b.

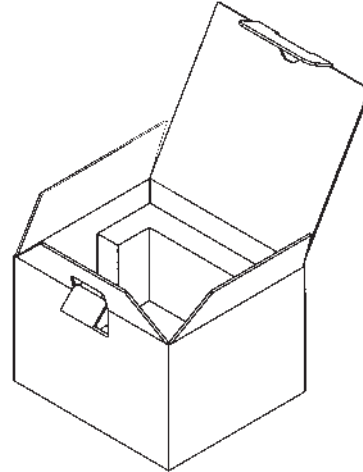

This carton box is a standard accessory of the GD-ROM drive. If you want to obtain the carton box itself separately, specify the part number 601-11031.

## HOW TO USE THE CARTON BOX (GD-ROM DRIVE)



When you want to order for replacing or repairing service of the GD-ROM drive that is used by the product, pack it in a carton box as instructed below, and then deliver the carton box to a service agent. If you do not observe the instruction, your order may not be accepted or may be charged additionally. If you handle the GD-ROM drive differently from the following instructions, its components may be damaged.

- Contain the GD-ROM drive in a dedicated carton box. Do not disassemble it or remove any part from it unless otherwise instructed.
- Before containing the GD-ROM drive in a dedicated carton box, attach the GD-ROM drive lid (DISC LID) onto the drive and fix the lid with a screw.
- Before containing the GD-ROM drive in a dedicated carton box, remove the GD-ROM disk from the drive. Do not attempt to move the GD-ROM drive with a GD-ROM disk inside.
- Before containing the GD-ROM drive in a dedicated carton box, remove the GD-ROM drive bracket. Carefully keep the GD-ROM drive bracket and the 4 set screws, because they will be reused.
- When inserting the GD-ROM drive into a dedicated carton box, be careful about an inserting direction as illustrated below.
- The packing materials in a carton box are used as a cushion. Use them always when inserting the GD-ROM drive into a dedicated carton box. Do not bend them.

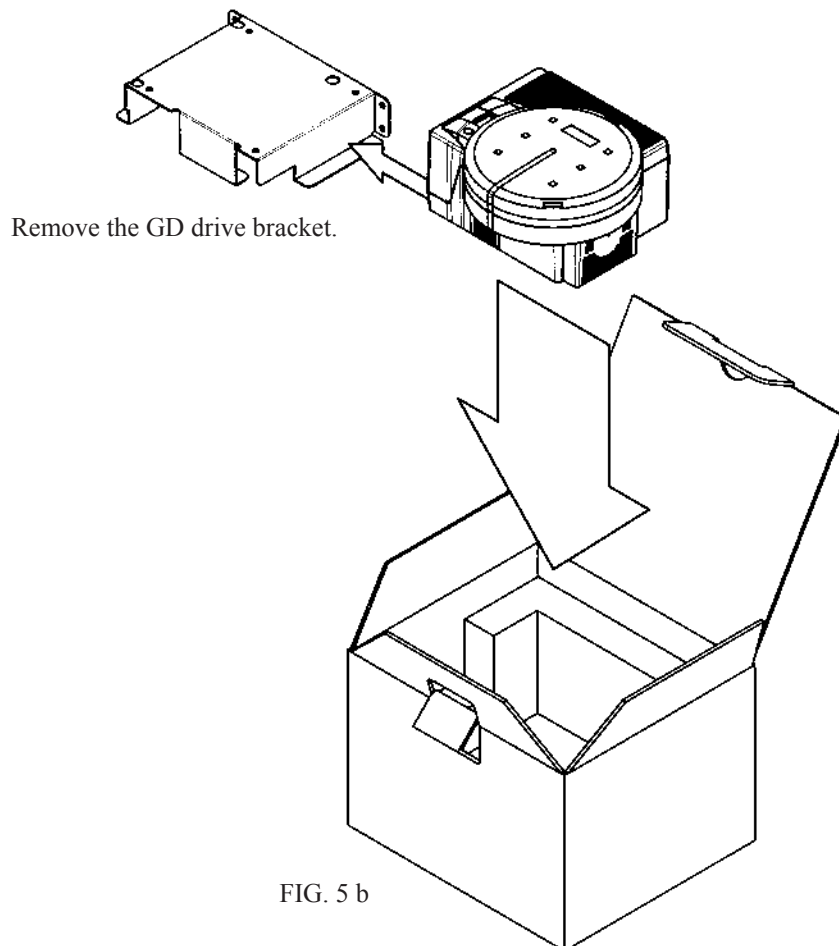

FIG. 5 b

## 6. ASSEMBLING AND INSTALLATION



- Perform assembly work by following the procedure herein stated. Failing to comply with the instructions can cause electric shock hazard.
- Perform assembling as per this manual. Since this is a complex machine, erroneous assembling can cause an electric shock, machine damage and or not functioning as per specified performance.
- When assembling, be sure to use plural persons. Depending on the assembly work, there are some cases in which working by one person alone can cause personal injury or parts damage.
- Ensure that connectors are accurately connected. Incomplete connections can cause electric shock hazard.
- Be careful so as not to damage wirings. Damaged wiring can cause electric shock and short circuit hazards.
- This work should be performed by the Location's Maintenance Man or Serviceman. Performing work by non-technical personnel can cause a severe accident such as electric shock. Failing to comply with this instruction can cause a severe accident such as electric shock to the player during operation.
- Provide sufficient space so that assembling can be performed. Performing work in places with narrow space or low ceiling may cause an accident and assembly work to be difficult.
- To perform work safely and avoid serious accident such as the cabinet's falling down, do not perform work in places where step-like grade differences, a ditch, or slope exist.



- When handling plastic parts, use care. Do not give a shock or apply excessive load to the fluorescent lamps and plastic parts. Failure to observe this can cause parts damage, resulting in injury due to fragments, cracks and broken pieces.
- To perform work safely and securely, be sure to prepare a step which is in a secure and stable condition. Performing work without using the step can cause violent falling down accidents.

When carrying out the assembly work, follow the procedure in the following 6-item sequence:

- 1 INSTALLATION OF BILLBOARD PLATE AND BILLBOARD PLATE R
- 2 SECURING IN PLACE (ADJUSTER ADJUSTMENT)
- 3 INSTALLING THE GD-ROM DRIVE (SETTING A GD-ROM DISK)
- 4 POWER SUPPLY, AND EARTH CONNECTION
- 5 TURNING POWER ON
- 6 ASSEMBLING CHECK

The master key (accessories) in addition to the tools such as a Phillips type screwdriver, Box nut screwdriver and wrench are required for the assembly work.

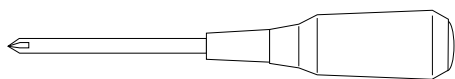

Phillips type screwdriver  
(for M3, M4 screw)

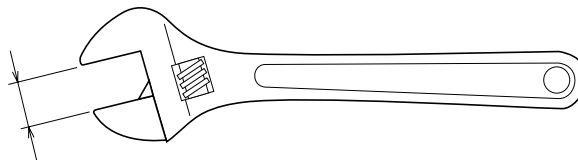

WRENCH (for M16 hexagon bolt)

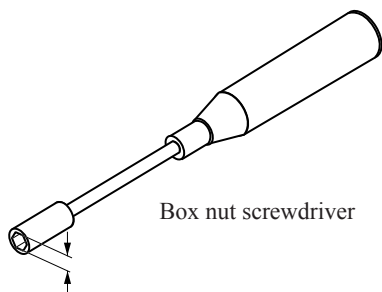

Box nut screwdriver

KEY MASTER

# 1 INSTALLATION OF BILLBOARD PLATE AND BILLBOARD PLATE R

- ① Remove the 4 truss head screws, and thereby remove the lamp cover B.
- ② Insert the billboard plate, and tighten the 4 truss head screws to fix the lamp cover B.

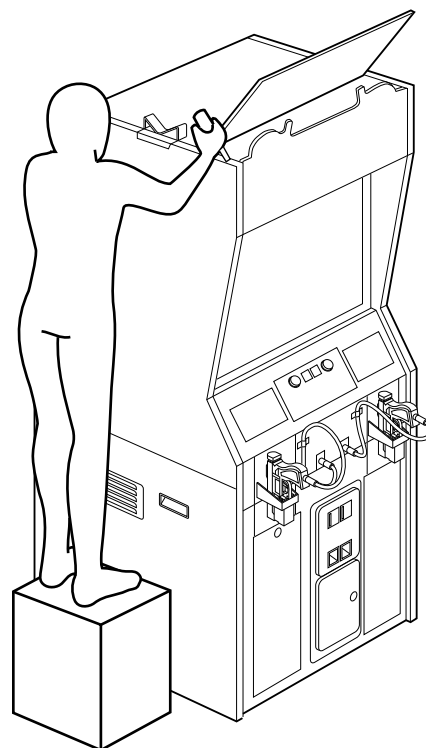
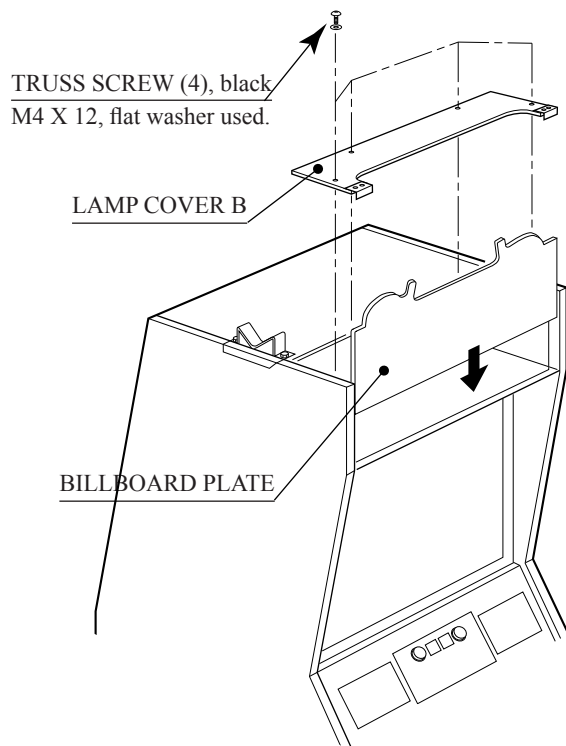

When performing work, prepare a step.

\* Drawings differ from actual game.

- ③ Insert the billboard plate R into a slot on the rear of the billboard case.
- ④ Using a both-side adhesive tape, stick the plate holder onto the rear of the billboard plate R.
- ⑤ Tighten the 2 tapping screws, and thereby fix the plate holder.

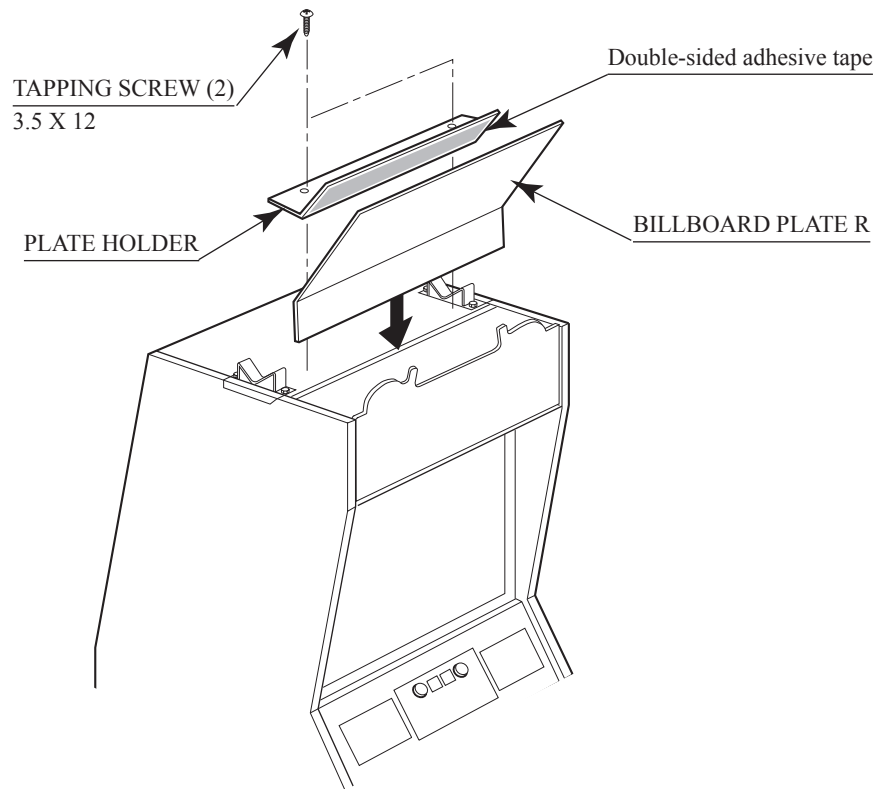

FIG 6. 1 b\*

\* Drawings differ from actual game.

# 2

## SECURING IN PLACE (ADJUSTER ADJUSTMENT)



Make sure that all of the adjusters are in contact with the floor. If they are not, the cabinet can move and cause an accident.

This machine has 4 casters and 4 adjusters. When the installation position is determined, cause the adjusters to come into contact with the floor directly, make adjustments in a manner so that the casters will be raised approximately 5mm. from the floor and make sure that the machine position is level.

- ① Move the machine to the installation position.
- ② Cause all of the adjusters to make contact with the floor. By using a wrench, make adjustments in the height of the adjusters to ensure that the machine's position is level.
- ③ After making adjustments, fasten the adjuster nut upward and secure the height of the adjuster.

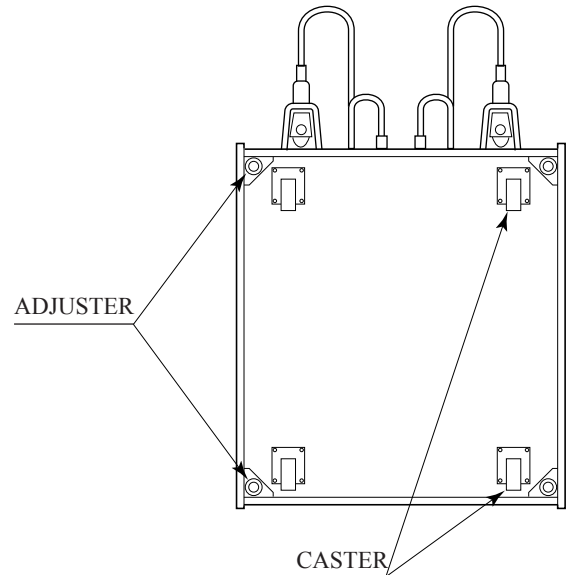

FIG. 6. 2 a BOTTOM VIEW

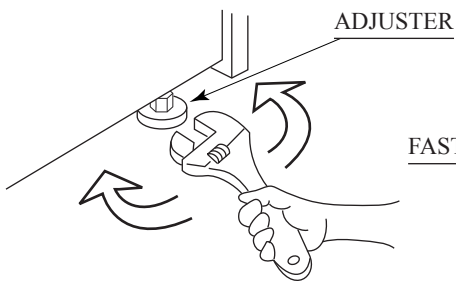

FIG. 6. 2 b ADJUSTER

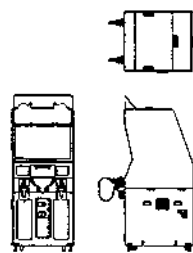
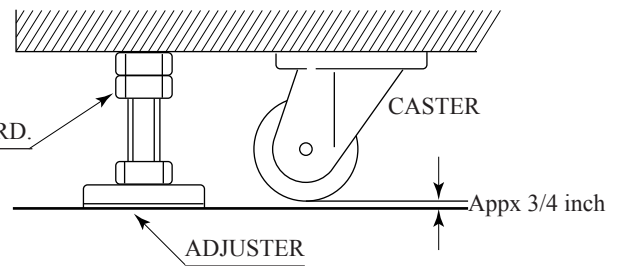

FIG. 6. 2 c  
Refer to this Fig. (Scale: 1/100) for the layout of the place of installation.

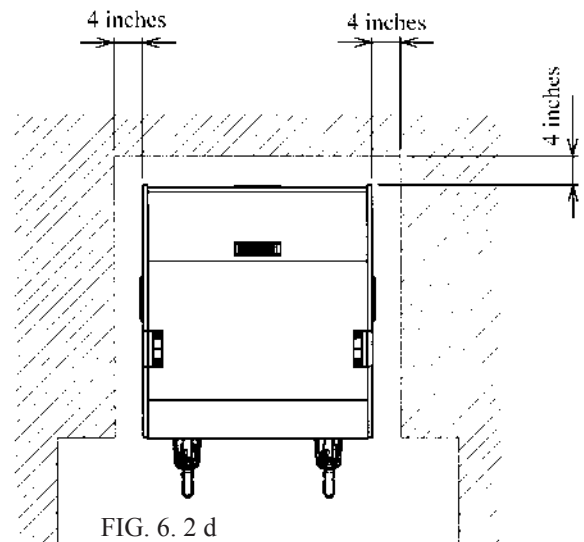

FIG. 6. 2 d  
Provide sufficient space so as to allow for ventilation by the ventilation fan.



# 3

## INSTALLING THE GD-ROM DRIVE (SETTING A GD-ROM DISK)



- Carefully handle the GD-ROM drive so as not to contaminate the disk and the readout lens with stains and dust particles.
- Do not continue to use the scratched GD-ROM disk. The scratched GD-ROM disk may cause the system to malfunction.
- Set the GD-ROM disk onto the GD-ROM drive with its labeled side facing upward.

① Unpack the shipping crate, and take out the GD-ROM drive, GD-ROM drive bracket, and GD-ROM disk.



GD DRIVE BRACKET



GD-ROM DRIVE

PHOTO 6. 3 a

② Use the 4 tapping screws to fix the GD-ROM drive bracket onto the GD-ROM drive. Be careful about a fixing direction.

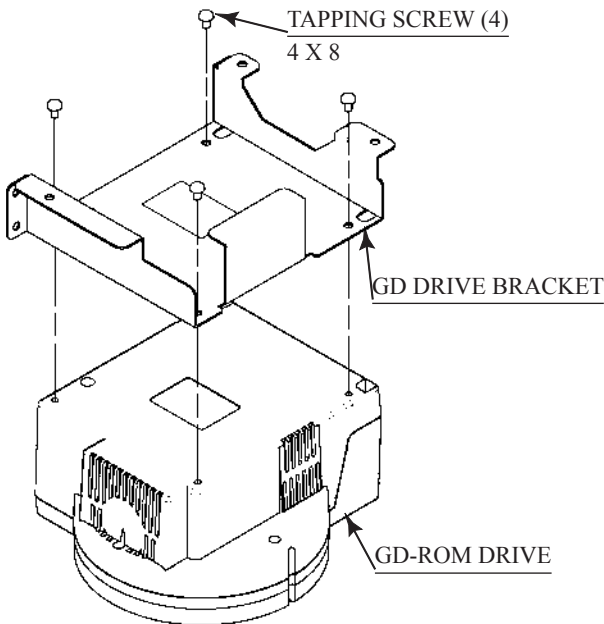
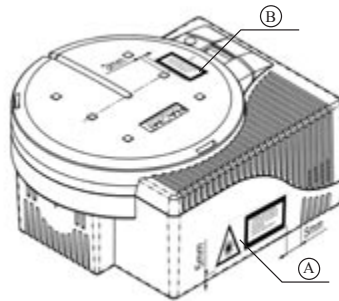
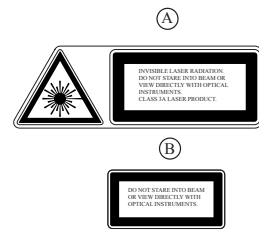

FIG. 6. 3 a



Application diagram



Please follow the drawing and place the sticker with the right language.

FIG. 6. 3 b

CAUTION for U. S. A., Europe, and Australia:  
Attach the 2 caution stickers for a laser ray onto the GD-ROM drive.

- ③ Remove the 1 truss head screw that fixes the GD-ROM drive lid (DISC LID). And turn clockwise the lid to remove.

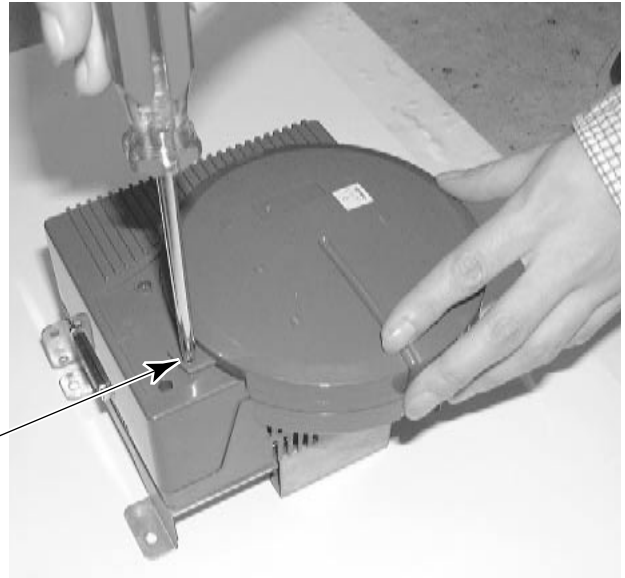

TRUSS SCREW (1)  
M3 X 8

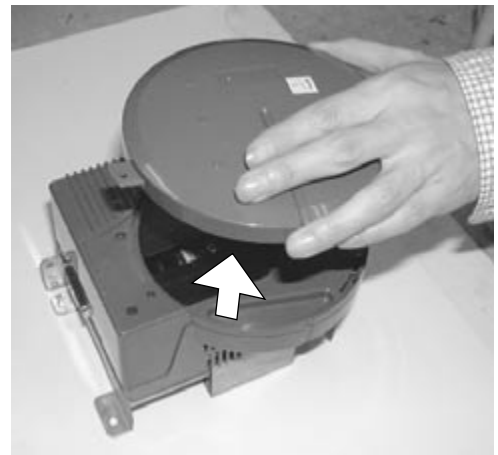
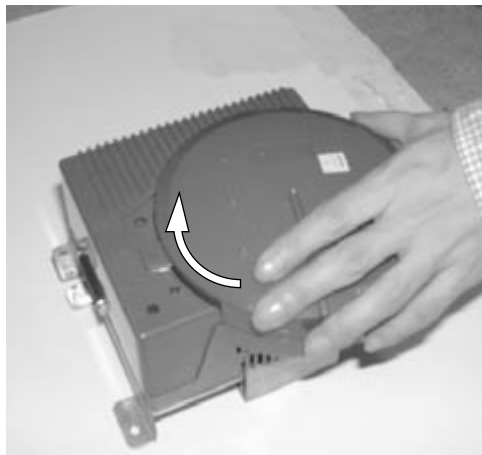

PHOTO 6. 3 b

- ④ Set the GD-ROM disk onto the GD-ROM drive with its labeled side facing upward.
- ⑤ Return the lid to its original place, and fix it with 1 truss head screw. Be careful not to fasten the screw too tightly.

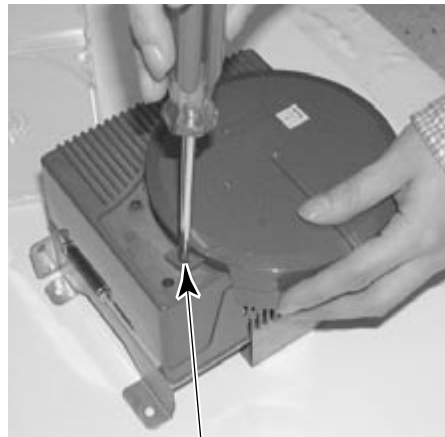

PHOTO 6. 3 c

TRUSS SCREW (1)  
M3 X 8

- ⑥ Unlock the front-left door, and thereby remove the door from the cabinet.

UNLOCK

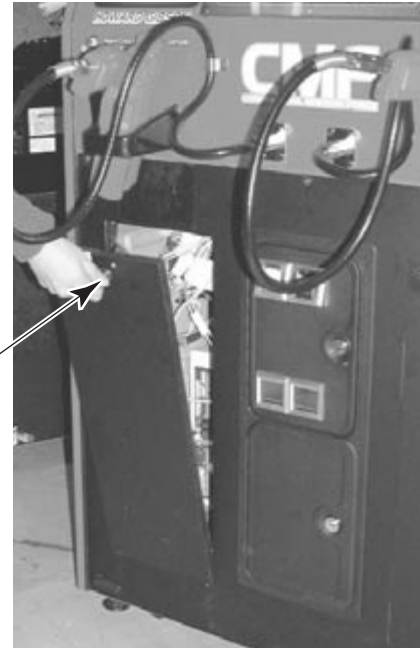

PHOTO 6. 3 d \*

- ⑦ Now you will take out the ASSY MAIN BD from the cabinet and mount the GD-ROM drive onto it. First, remove the 7 connectors from the upper section of the rear of the door.

Disconnect the connector.



PHOTO 6. 3 e \*



D-SUB connector

- ⑧ Remove the D-SUB connector from the filter board (a part of the NAOMI board on the ASSY MAIN BD). Unclamp the cable with the D-SUB connector.

PHOTO 6. 3 f \*

\* Guns are different in actual game.

- ⑨ Remove the 2 wing bolts that fix the ASSY MAIN BD's base (a wooden plate).
- ⑩ Take out the ASSY MAIN BD from the cabinet. In this instance, be careful not to catch the wires on or in the parts.

WING BOLT (2)  
M4 X 30, flat washer used

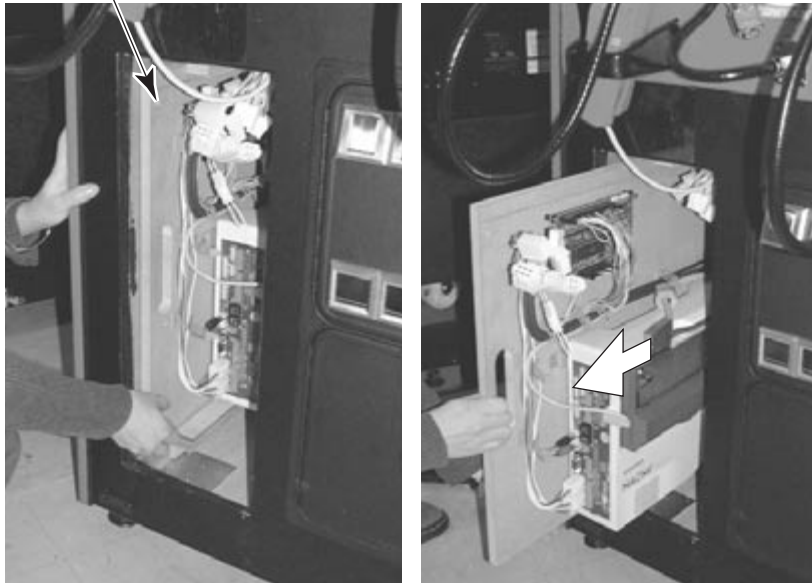
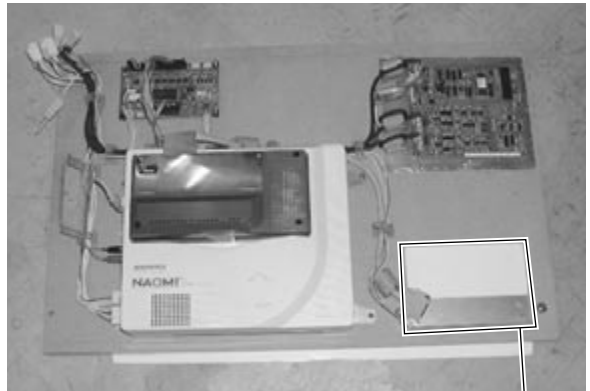

PHOTO 6. 3 g

- ⑪ Place the ASSY MAIN BD on a flat horizontal surface.



GD-ROM drive is installed here.

PHOTO 6. 3 h

- ⑫ Set the GD-ROM drive onto the ASSY MAIN BD. Tighten the 4 flange nuts to fix the ASSY MAIN BD.

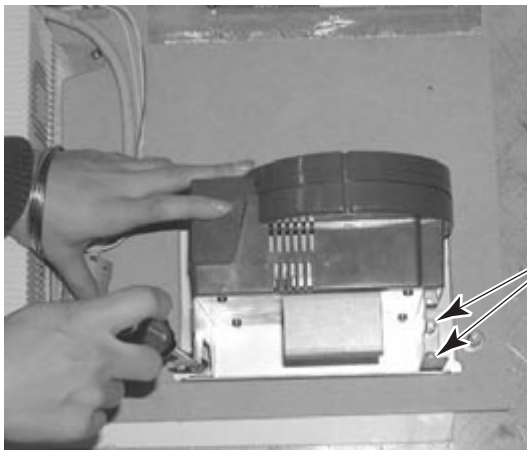

FLANGE NUT (4)  
M4

PHOTO 6. 3 i

- ⑬ Insert both the GD cable connector (for data communication) and the power cord connector (JST NH6P) into the GD-ROM drive. Be careful about an inserting direction in this instance. Make sure that the connectors are inserted firmly and completely.

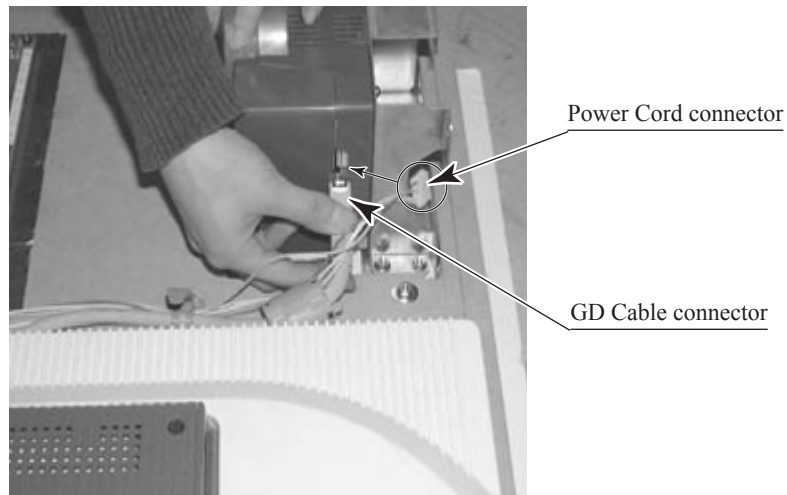

PHOTO 6. 3 j

- ⑭ Return the ASSY MAIN BD (now installed with the GD-ROM drive) into the cabinet. Tighten the 2 wing bolts, and thereby fix the base.



PHOTO 6. 3 k

- ⑮ Following the above-described actions in a reverse order, connect the connectors, clamp the wires/cables, and install the front-left door.

# 4

## POWER SUPPLY, AND EARTH CONNECTION



- Be sure to independently use the power supply socket outlet equipped with an Earth Leakage Breaker. Using a power supply without an Earth Leakage Breaker can cause a fire when electric leakage occurs.
- Ensure that the "accurately grounded indoor earth terminal" and the earth wire cable are available (except in the case where a power cord plug with earth is used). This product is equipped with the earth terminal. Connect the earth terminal and the indoor earth terminal with the prepared cable. If the grounding work is not performed appropriately, customers can be subjected to an electric shock, and the product's functioning may not be stable.
- Ensure that the power cord and earth wire are not exposed on the surface (passage, etc.). If exposed, they can be caught and are susceptible to damage. If damaged, the cord and wire can cause electric shock and short circuit accidents. Ensure that the wiring position is not in the customer's passage way or the wiring has protective covering.
- After wiring power cord on the floor, be sure to protect the power cord. Exposed power cord is susceptible to damage and causes an electric shock accident.

The AC Unit is mounted on the rear of the machine. The AC Unit has Circuit Protector, Main SW, Earth Terminal and the Inlet which connects the Power Cord.

- ① Ensure that the Main SW is OFF.

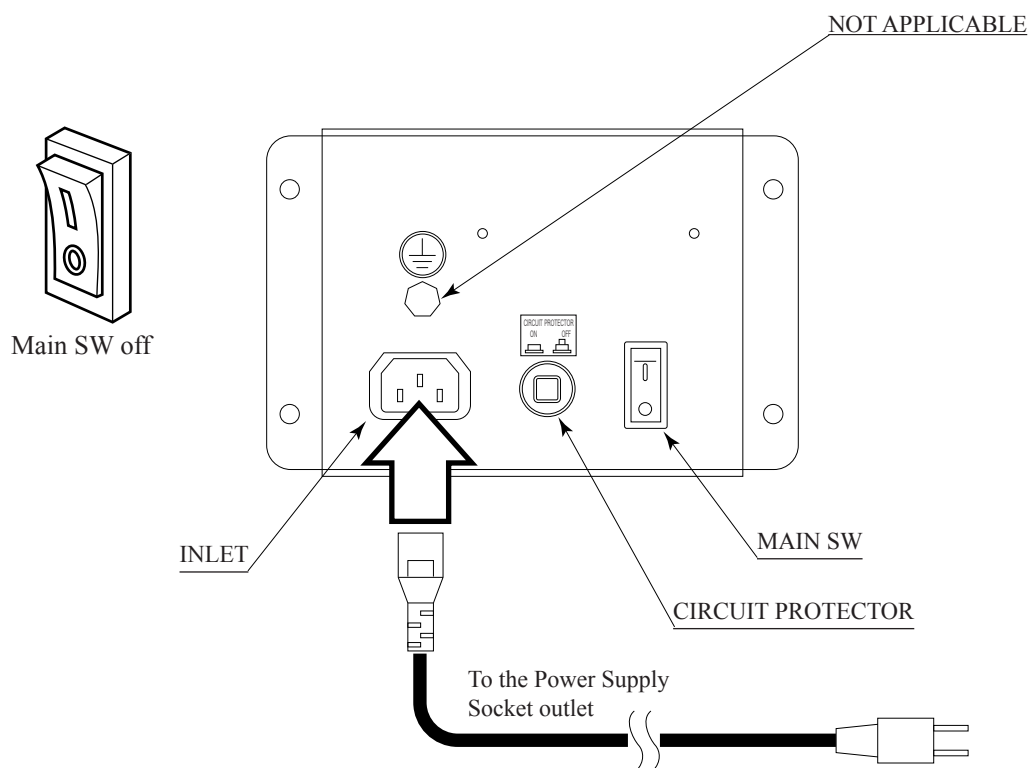

FIG. 6. 4 a AC unit

# 5

## TURNING POWER ON

Turn on the AC unit's main switch to connect the power. When the power is connected, the fluorescent light in the billboard becomes on. A few seconds later a system startup screen appears and then an advertising screen (plying for a player screen) appears.

Time until displaying an advertising screen is not constant; it varies from some tens of second up to several minutes. This is due to the functional characteristics of the GD-ROM system's rechargeable battery and therefore normal.

When an advertising screen appears, sound is output from the speakers on the right and left of the PTV cabinet. Sound is not output if you have set the function to off.

After the power is disconnected, the system can maintain the data of credit number and ranking. The system cannot maintain, however, the fractional number of coins (not enough for one credit) and the bonus adder count data.

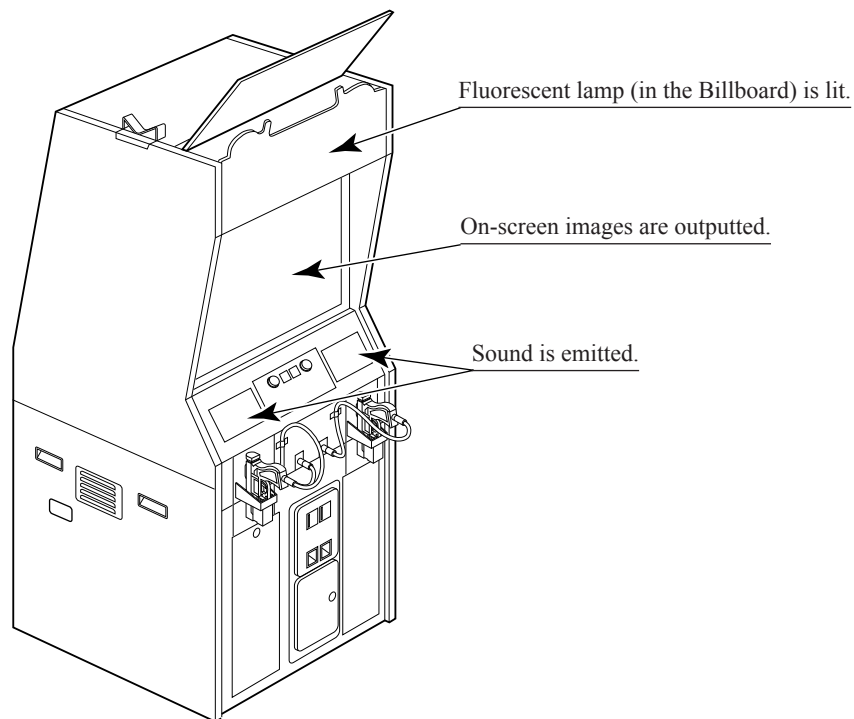

FIG. 6. 5 \*

\* Guns are different in actual game.

# 6

## ASSEMBLING CHECK

In the TEST MODE, ensure that the assembly has been made correctly and IC BD. is satisfactory (refer to Section 9).

In the test mode, perform the following test:

### (1) MEMORY TEST

Selecting the RAM TEST and DIMM BOARD TEST on the test mode menu screen causes the on-board memory to be tested automatically. The game board is satisfactory if the display beside each IC No. shows GOOD.

```
RAM TEST

IC29 GOOD
IC35 GOOD
IC09 GOOD   IC10 GOOD
IC11 GOOD   IC12 GOOD
IC16 GOOD   IC18 GOOD
IC20 GOOD   IC22 GOOD
IC17 GOOD   IC19 GOOD
IC21 GOOD   IC23 GOOD

PRESS TEST BUTTON TO EXIT
```

```
DIMM BOARD TEST

PROGRAM VER : 1.02
DIMM SLOT 0 : GOOD
DIMM SLOT 1 : GOOD
DIMM STATUS : GOOD

CHECKING DIMM BD
DIMM0 -      GOOD
DIMM1 -      GOOD
IC34,35S -   GOOD
IC10,11S -   GOOD
GD DRIVE -   GOOD
--- COMPLETE ---

PRESS TEST BUTTON TO EXIT
```



## (2) C.R.T. TEST

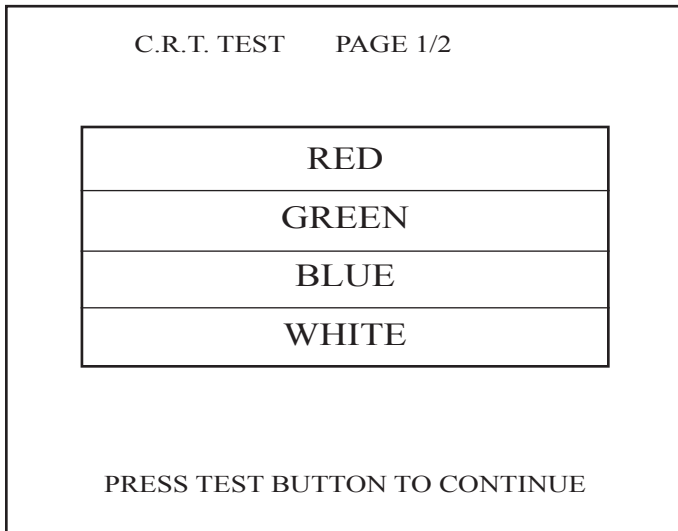

In the TEST mode menu, selecting C.R.T. TEST allows the screen (on which the monitor is tested) to be displayed. Although the monitor adjustments have been made at the time of shipment from the factory, make judgment as to whether an adjustment is needed by watching the test mode screen. If it is necessary, adjust the monitor by referring to Section 11.

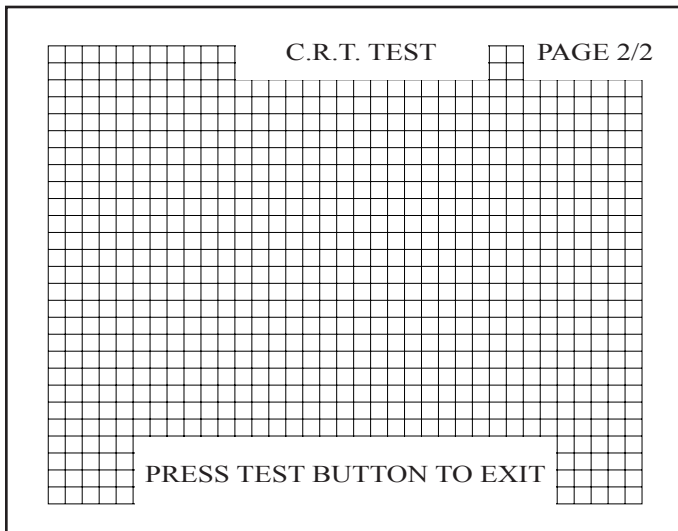

## (3) INPUT TEST

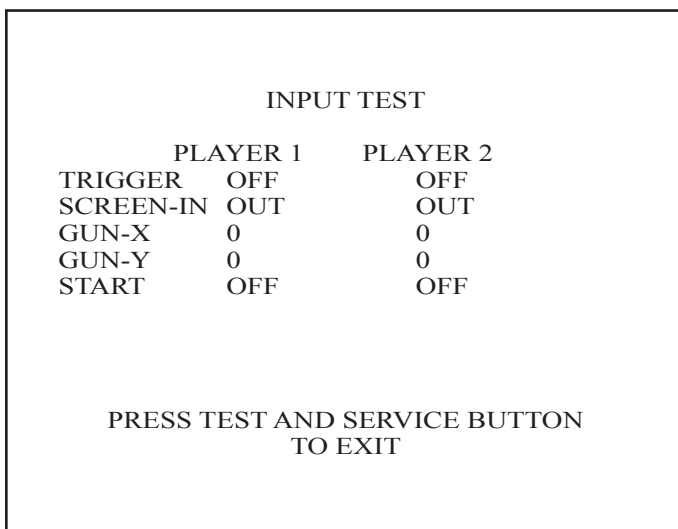

Selecting the INPUT TEST on the game test mode menu screen causes the screen (on which each switch is tested) to be displayed. Press each switch. If the display beside each switch indicates "ON," the switch and wiring connections are satisfactory.

#### (4) OUTPUT TEST

Select OUTPUT TEST from the menu in the test mode to cause the screen (on which each lamp and wiring connections are tested) to appear. Ensure that lamp light up satisfactorily.

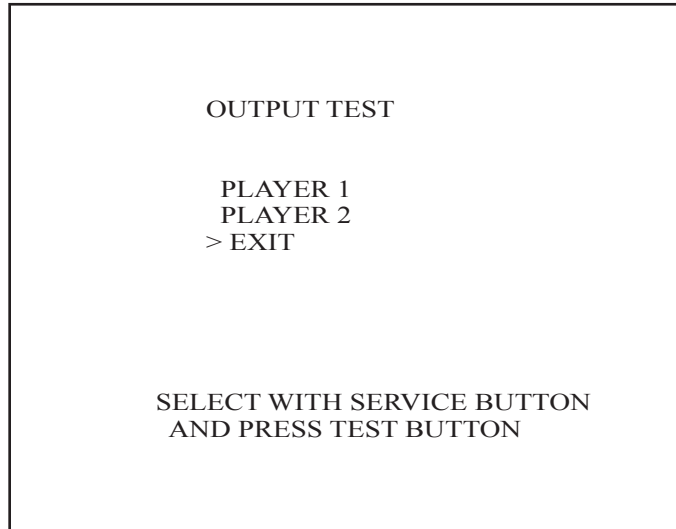

#### (5) GUN ADJUSTMENT

Before starting the operation, play the game by yourself and make sure that the gun readjustment is not needed and that you can play the game without a problem. Although completed at the factory, the gun adjustment may be necessary because after the adjustment the product has been disassembled for packing and shipping.

For more information about the gun adjustment, see Section 9-3E.

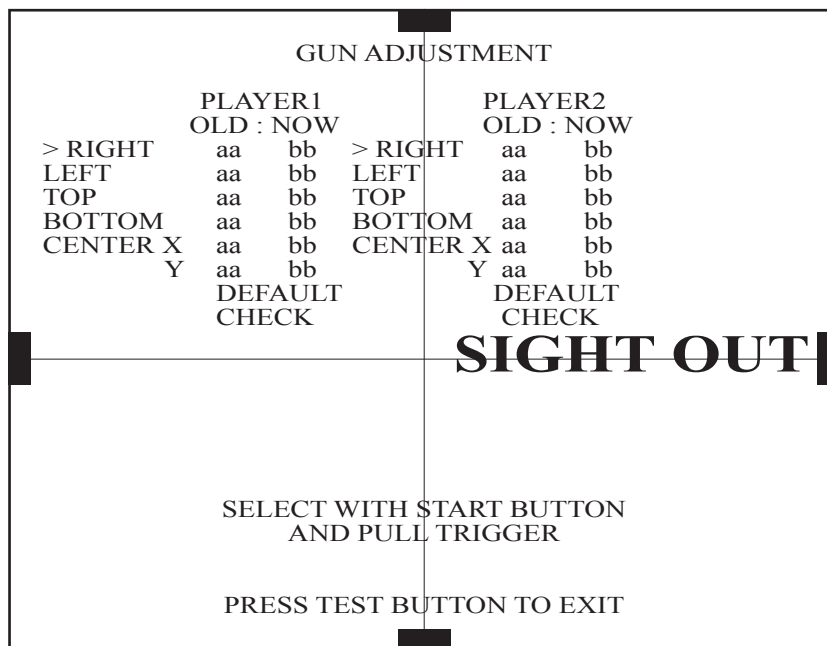

Perform the above inspections also at the time of monthly inspection.

As for the gun adjustment described in Section (5) above, weekly confirm that the gun is properly adjusted.

## THE INTERFERENCE PREVENTION WIRING



- In order to prevent electric shock and short circuit hazards, be sure to turn power off before performing work.
- Be careful so as not to damage wirings. Damaged wiring can cause fire, electric shock and short circuit hazards.
- Do not expose the IC BD, etc. without a good reason. Failure to observe this can cause electric shock hazard or malfunctioning.
- Work should be performed by the Location's Maintenance Man or technical personnel. Performing work by those who do not have technical knowledge and expertise can cause electric shock accident or malfunctioning.

When the game machines of a same or similar type are installed side by side, their sensors may interfere with each other. To reject the interference, follow the procedure below.

The following game machines employ a same or similar type of sensor. If interference happens to the sensors, operation of the games may be mutually disturbed.

- VIRTUA COP 2, U/R type and DX type
- THE HOUSE OF THE DEAD, U/R type and DX type
- THE HOUSE OF THE DEAD 2, U/R type and DX type
- THE LOST WORLD, U/R type and DX type
- BRAVE FIRE FIGHTERS
- SAMBA DE AMIGO
- CONFIDENTIAL MISSION, U/R type and DX type

- ① Disconnect the power.
- ② Unlock the front-left door, and thereby remove the door from the cabinet.
- ③ Locate an interference rejection wire inside the cabinet.

If the game machines of a same or similar type are installed side by side, place them alternately (place the machine with an interference rejection wire next to the machine without).



INTERFERENCE PREVENTION WIRING  
SPY-60019

PHOTO 6. 6

## 7. PRECAUTIONS TO BE HEEDED WHEN MOVING THE MACHINE



- When moving the machine, be sure to unplug the power plug. Moving the machine with the plug as is inserted can damage the power cord, and cause fire and electric shock hazards.
- When moving the machine on the floor, retract the Adjusters and ensure that Casters make contact with the floor. During transportation, pay careful attention so that Casters do not tread power cords and earth wires. Damaging the power cords can cause electric shock and short circuit hazards.



- When moving the product, do not push the Front Glass. The Glass part could be damaged and glass fractions may cause injury.
- When lifting the cabinet, be sure to hold the grip portions or bottom part. Failure to observe this may damage parts and cause injury.
- Do not move the product with a GD-ROM disk inside. Remove the GD-ROM disk before moving the product. Failure to observe this instruction may cause the GD-ROM disk and/or GD-ROM drive to be damaged.

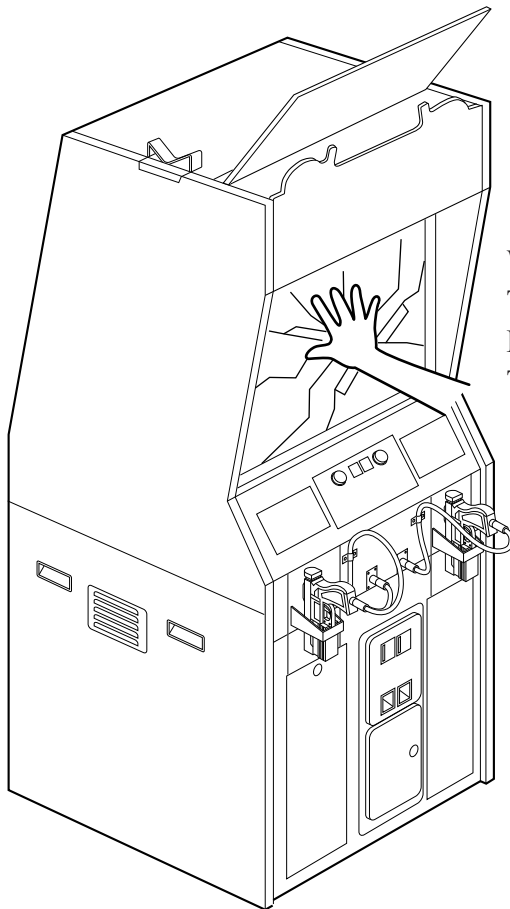

WHEN MOVING  
THE PRODUCT,  
DO NOT PUSH  
THE FRONT GLASS.

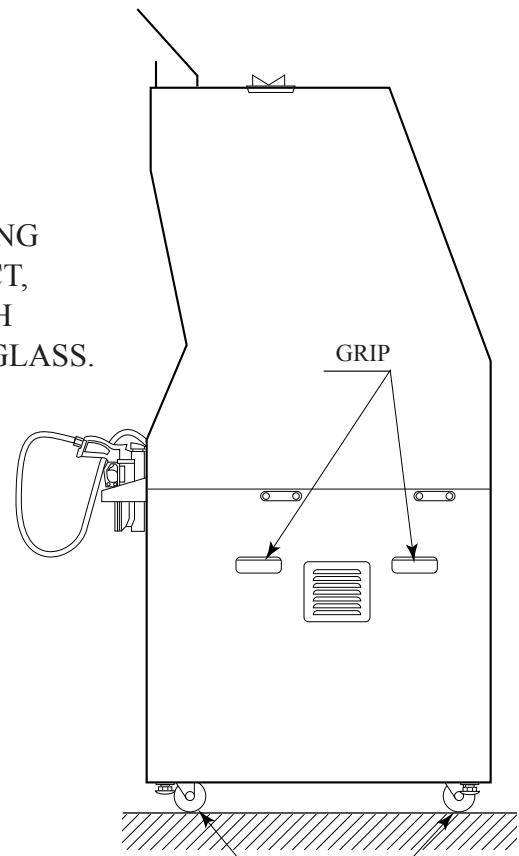

FIG. 7 \*

Have casters make contact with the floor.

\* Guns are different in actual game.

## 8. CONTENTS OF GAME

The following explanations apply to the case the product is functioning satisfactorily. Should there be any moves different from the following contents, some sort of faults may have occurred. Immediately look into the cause of the fault and eliminate the cause thereof to ensure satisfactory operation.

While the power is connected, the fluorescent light in the billboard is on and demonstration images and ranking data are displayed. During this advertising period, sound is also output from the speakers on the right and left of the cabinet. Sound is not output if you have set the function to off. Each of the right and left start buttons is integrated with a light. The light flashes when coins are inserted sufficiently for a play.

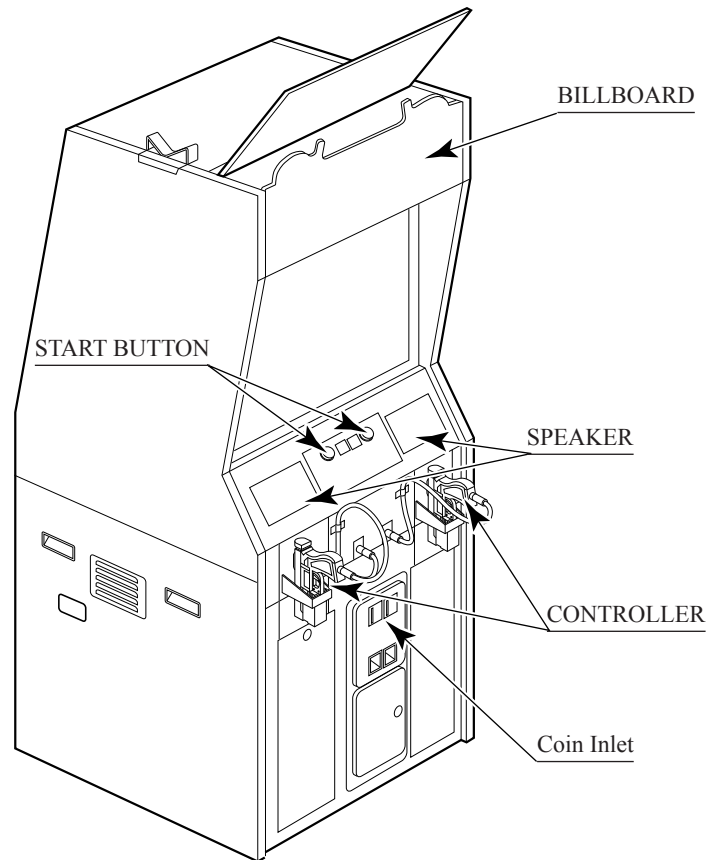

FIG. 8 \*

\* Guns are different in actual game.

## GAME OUTLINE

- This is an action adventure game with the theme of a giant treasure hunt.
- The players take on the role of treasure hunters, fighting their way through various traps using their magic rods to defeat the guardians of the treasure.
- The game is made up of three stages.
- Two players can play simultaneously.

## STORY

Somewhere among the pyramids, the world's last remaining secret treasure is sleeping. However, each time you set foot in the dungeon where it lies hidden, the route to the treasure changes....

Two treasure hunters with magic rods in hand.

Can they miraculously defeat the guardians and avoid countless traps to retrieve the hidden treasure?

## PLAYER CHARACTERS



### LINDA ROBERTS

Twenty-four years old. A veteran adventurer whose quests have taken her around the world, she seeks the treasure of ancient ruins. She possesses a courage and decisiveness unmatched by any man.



### JAMES COOPER

Twenty-eight years old. A bright young man from the West Coast. This will be his first adventure.

He has talked the veteran character (female) into bringing him along against her will. His lack of experience and simplicity of character often confounds his partner.

## SPECIAL CHARACTERISTICS OF THE GAME

### ① **Random Map System**

This Game adopts a random map system where the route changes each time the game is played. Under this system, the room layout and order of rooms to be passed through for each stage change every time the game is started.

### ② **Customizable Players**

This game allows players to select rod effects and defense items. Using these functions, players are able to adequately prepare themselves for battle with difficult enemies and also to compensate for their partners' weak points.

### ③ **Free Exchange of Items/Lives**

During two-player mode, players can give lives to their partners or exchange rod effects.

## HOW TO PLAY

### ① **Insert Coins**

Insert coins and the credit display at the bottom of the screen will go up.

When enough coins have been inserted for a single-player game, the "INSERT COIN(S)" message at the bottom of the screen will change to "PRESS START BUTTON" and both Start buttons will flash.

- Up to nine credits can be counted at a time. If additional coins are inserted they will not be counted as credits nor will they be returned. However, they will register on the data display and coin meter as having been inserted.

A player who wants to join a game in progress should insert coins during the game and press the Start button. If the number of credits remaining is enough, the Start button on the side not being played will flash. A player can join in during the game by pressing this button.

### ② **Rod Controller Settings**

A player decides which side (left or right) to play by pressing the Start button on the desired side

Press Start button and the Rod Controller Settings screen will appear.

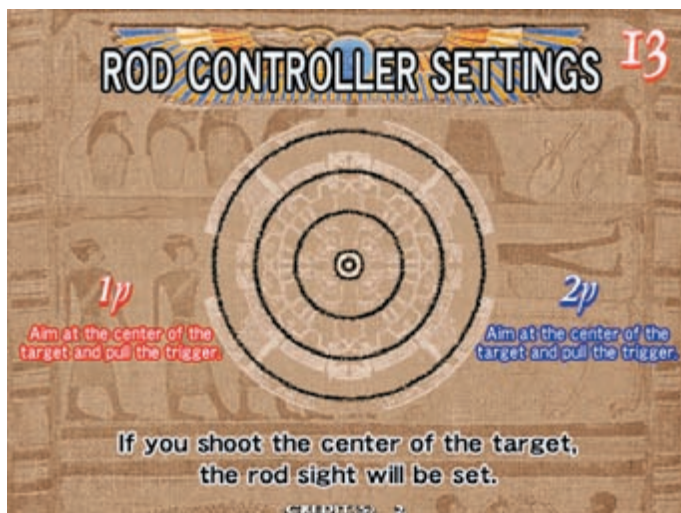

Players adjust the aim of the Gun Controllers by aiming and firing at the target in the center of the screen.

### ③ Rod Effects - Selecting Player Items

This selection screen appears after the Gun Controllers have been adjusted.

#### 1. Rod Effect Selection



Select the effect of the rod. Only one of the three effects can be selected.

- LIGHT: This allows the most shots to be fired at once, but shot strength is correspondingly less powerful.
- SPARK: This effect provides a balance between shot strength and frequency.
- FIRE: This effect is the most powerful but allows the least number of shots.

#### 2. Equipment Selection



Each is only effective once.

They regain their effectiveness when Continue is selected.



### 3. Exchanging Lives (Two-Player Mode Only)



Players can give lives to and receive lives from a partner. However, players cannot reduce their lives to zero.

#### ④ Current Game Edition

- (1) Player One : Score
- (2) Player One: Equipment Selected
- (3) Enemies
- (4) Player One: Number of Rod Effects
- (5) Player One: Number of Stones
- (6) Player One: Number of Lives Remaining
- (7) Player Two: Score
- (8) Player Two: Equipment Selected
- (9) Player Two: Number of Rod Effects
- (10) Player Two: Number of Stones
- (11) Player Two: Number of Lives Remaining



Rod effects and lives for Player One ( on the left side) are displayed at the lower left of the screen. Rod effects and lives for Player Two ( on the right side) are displayed at the lower left of the screen.

### <Recharging the Rod>

- The rod loses its effectiveness after a certain period of time, depending on the effect that the player has chosen.
- When the rod loses its effectiveness, the message RELOAD will be displayed on the screen. To restore the effectiveness of the rod, the player should point the tip of the rod away from the screen.

### <Losing Lives>



Reload Display (Displayed when bullets are used up.)



- Each player possesses a certain number of lives.
- The player loses a life each time they suffer an enemy attack (biting, clawing, slashing or hitting).
- A sight appears each time players battle a boss character. Players lose life if they fail to shoot the enemy down by the time the sight turns completely red.

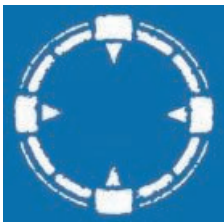

**Sight**

### <Increasing Score>

- Score is increased when a player discovers treasure in pots or acquires treasure from enemy characters.
- Complete the mini game in the last area of each stage to acquire even more treasure!

### <Decreased Score>

- Score decreases each time the game is continued.

### <Items>

- Items sometimes appear when players defeat enemies or smash pots.
- Players can collect items by shooting them to increase their scores or gain lives.



**Life**

- Collect one Life to increase the number of lives by one.



**Stone**

- Collect three Stones to increase the number of lives by one.



**Treasure Item**

- This is enemy treasure.
- Reveal the Treasure by defeating the enemy for bonus points.

**<Boss Battles>**

- Clear each stage by defeating the Boss Character waiting at the end of the stage.
- To defeat the Boss Character, The player must reduce its Life Meter to zero.



### <Treasure Hunt Minigame>

- When the Boss Character of each stage has been defeated, a minigame begins where players can acquire the Boss's Treasure.
- During a Minigame, follow the instructions that appear on the screen.
- Players can increase their scores by completing the Minigame and acquiring the Treasure.



### <Rankings>

- The Stage Clear screen appears when the Minigame ends.
- This screen displays players' rankings along with their scores for each stage.



⑤ **Player Item Exchange** (Two-Player Mode Only)

- Clear a stage during two-player mode and the Item Exchange screen is displayed. (If a partner joined while a game was in progress, the partner's Item Selection screen will be displayed.)
- Players can exchange rod effects, equipment and lives.



⑥ **Game Over**

- The following conditions result in GAME OVER:
  - 1) Reduction of players' lives to zero.
  - 2) Clearing of Stage Three.

⑦ **Continue**

- To continue when a player's lives are reduced to zero, they must insert enough coins to continue and then press the Start Button. If there are enough credits remaining to continue, the game can be continued by simply pressing the Start Button.

⑧ **Hi-Score**

- Players whose scores are in the top twenty can record their names.

## PLAY TIPS

### **Shoot the Treasure For Increased Points!**

- Points increase with the number of successful shots on enemy treasure.

### **Stop Multiple Enemies in Their Tracks!**

- Simultaneous attacks by multiple enemies are extremely dangerous.
- Be sure to create situations where they can be dealt with one-on-one.

### **Aim at the Shoulders and Legs of Enemies With Shields!**

- Enemies with shields may be encountered.
- Shields deflect rod effects, so aim and fire at unshielded areas.

## 9. EXPLANATION OF TEST AND DATA DISPLAY

By operating the switch unit, periodically perform the tests and data check. When installing the machine initially or collecting cash, or when the machine does not function correctly, perform checking in accordance with the explanations given in this section.

The following shows tests and modes that should be utilized as applicable.

This product's basic system consists of the NAOMI game board and the GD-ROM drive. The system enables you to play several games one after the other just by changing a GD-ROM disk that is to be set on the GD-ROM drive.

The product supports, therefore, the following 2 test modes:

- (1) System test mode for an automatic self-diagnostic test (generally used by every product that contains the basic system) and a coin assignment (specifically used by this product) and
- (2) Game test mode for testing the input/output control devices and setting the difficulty level (specifically used by this product).

This manual does not cover the automatic self-diagnostic test. For more information about the system test mode, see the attached GD-ROM Service Manual.

TABLE 9 EXPLANATION OF TEST MODE

ITEMS	DESCRIPTION	REFERENCE SECTIONS
INSTALLATION OF MACHINE	When the machine is installed, perform the following: 1. Check to ensure each is the standard setting at shipment. 2. Check each Input equipment in the INPUT TEST mode. 3. Check each Output equipment in the OUTPUT TEST mode. 4. Test on-IC-Board IC's in the SELF-TEST mode.	SERVICE MANUAL  SERVICE MANUAL
MEMORY	This test is automatically executed by selecting RAM TEST, or ROM BOARD TEST in the Menu mode.	SERVICE MANUAL
PERIODIC SERVICING	Periodically perform the following: 1. MEMORY TEST 2. Ascertain each setting. 3. To test each Input equipment in the INPUT TEST mode. 4. To test each Output equipment in the OUTPUT TEST mode.	SERVICE MANUAL
CONTROL SYSTEM	1. To check each Input equipment in the INPUT TEST mode. 2. Adjust or replace each Input equipment. 3. If the problem still remains unsolved, check each equipment's mechanism movements.	SERVICE MANUAL
MONITOR	In the Monitor Adjustment mode, check to see if Monitor (Projector) adjustments are appropriate.	SERVICE MANUAL
IC BOARD	1. MEMORY TEST 2. In the SOUND TEST mode, check the sound related ROMs.	SERVICE MANUAL
DATA CHECK	Check such data as game play time and histogram to adjust the difficulty level, etc.	SERVICE MANUAL

9 - 1 SWITCH UNIT AND COIN METER



Never touch places other than those specified. Touching places not specified can cause electric shock and short circuit accidents.



- Adjust to the optimum sound volume by considering the environmental requirements of the installation location.
- If the COIN METER and the game board are electrically disconnected, game play is not possible.

SWITCH UNIT

Open the coin chute door, and the switch unit shown will appear.  
The functioning of each SW is as follows:

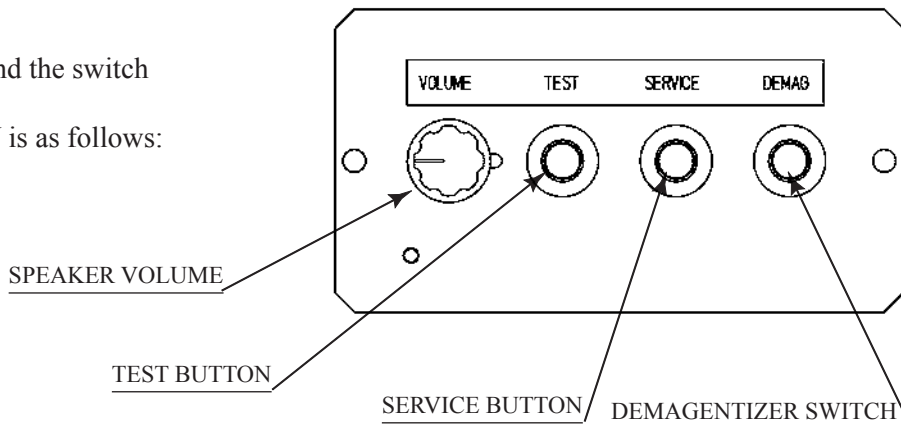

FIG. 9. 1 a SWITCH UNIT

TEST BUTTON:  
TEST

For the handling of the test button, refer to the following pages.

SERVICE BUTTON:  
SERVICE

Gives credits without registering on the coin meter.

SPEAKER VOLUME:  
SPEAKER

Adjusts sound volume for all of the machines' Speakers. Adjust to an appropriate sound volume by considering the environmental requirements of the installation location.

DEMAGNETIZER SWITCH:  
DEMAG.

Eliminates the on-screen color unevenness due to magnetization of CRT. First use this SW before performing the monitor's color adjustment.

COIN METER

Open the Cashbox Door by using the key to have the Coin Meter appear underneath the Cashbox.

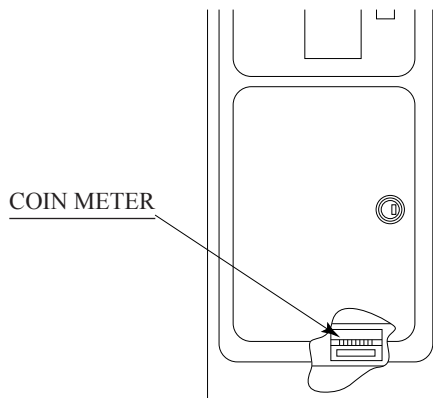

FIG. 9. 1 b





- The contents of settings changed in the TEST mode are stored when the test mode is finished from EXIT in the menu mode. If the power is turned off before the TEST mode is finished, the contents of setting change become ineffective.
- Executing "BACKUP DATA CLEAR" in the SYSTEM TEST MODE does not clear the BOOKKEEPING data in the GAME TEST mode.
- Entering the TEST mode clears fractional number of coins less than one credit and BONUS ADDER data.
- Perform setting as per specified in this manual for operation. If setting not specified is performed for operation, proper function of this product may not be obtained.

In the SYSTEM TEST MODE, IC BD functioning can be checked, the monitor adjusted, and the coin setting performed.

Refer to GD-ROM SERVICE MANUAL for the details. Note that the setting of the following items need to be performed in accordance with the instruction given.

- CABINET TYPE : 2 PLAYER(S)
- MONITOR TYPE : HORIZONTAL
- SERVICE TYPE : COMMON
- COIN CHUTE TYPE : COMMON

Select GAME TEST MODE from the System Menu screen to display the Game Test Menu screen.

Use the SERVICE Button to move the cursor to the desired test item.  
Press the TEST Button to enter the selected item.

**<Game Test Menu Screen>**

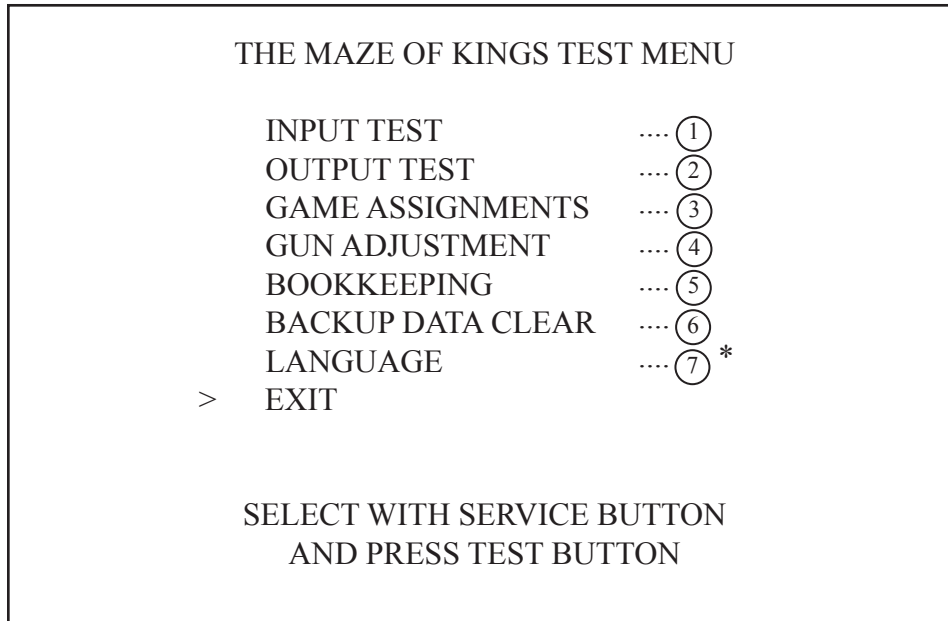

After making changes, be sure to select EXIT and press the TEST Button in order to enable the new settings.

Move the cursor to EXIT and press the TEST Button to return to the System Menu screen.

\* For overseas version other than US, Australia, and Korea.

## ① INPUT TEST

Select INPUT TEST to display the following screen and check the status of input devices. This test should be used periodically to check that each input device is functioning correctly.

### <INPUT TEST Screen>

INPUT TEST		
	PLAYER 1	PLAYER 2
TRIGGER	OFF	OFF
SCREEN-IN	OUT	OUT
GUN-X	0	0
GUN-Y	0	0
START	OFF	OFF
SERVICE	OFF	
TEST	OFF	

PRESS TEST AND SERVICE BUTTON  
TO EXIT

Pull the gun's trigger. If it is functioning correctly, the TRIGGER indicator will switch from OFF to ON.

Point the barrel of the gun at the screen. If the gun is functioning correctly, the SCREEN-IN indicator will switch from OUT to IN and the indicators to the right of GUN-X and GUN-Y will display values within the 0 - ff range.

Press the START switch / button. If functioning correctly, the START indicator will switch from off to ON.

Press the SERVICE and TEST Buttons simultaneously to return to the Game Test Menu screen.

## ② OUTPUT TEST

Select OUTPUT TEST to display the following screen and check the status of each lamp. This test should be used periodically to check that the lamps are functioning correctly.

### <OUTPUT TEST Screen>

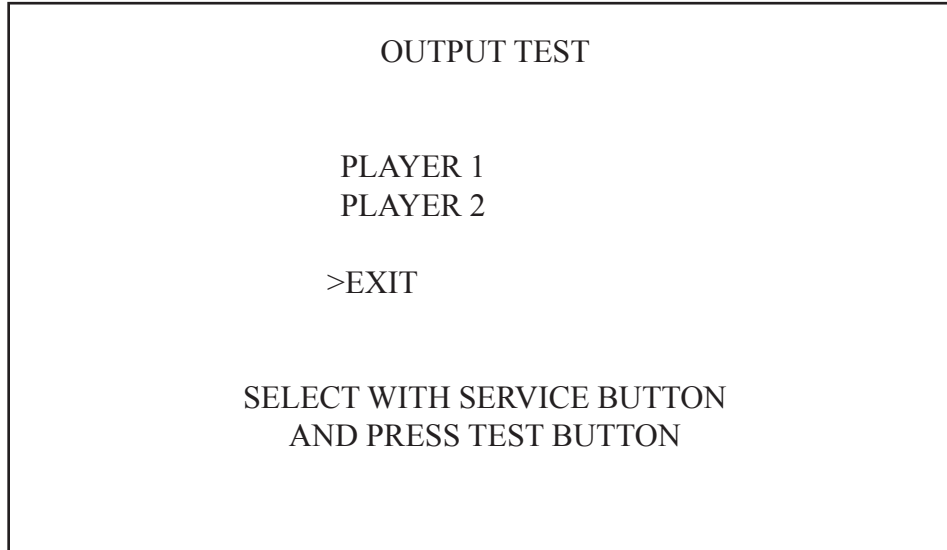

Select the item to be tested. If the connections are functioning correctly, the “1P” and “2P” buttons will flash when PLAYER 1 and PLAYER 2 are selected.

Move the cursor to EXIT and press the TEST Button to return to the Game Test Menu screen.

### ③ GAME ASSIGNMENTS

Select GAME ASSIGNMENTS to display the current gamesettings and make changes.

#### <GAME ASSIGNMENTS Screen>

GAME ASSIGNMENTS	
	EASY      HARD
GAME DIFFICULTY	■ ■ ■ ■ □ □ □ □
BOSS DIFFICULTY	■ ■ ■ ■ □ □ □ □
SHIFTING DIFFICULTY	■ ■ ■ ■ □ □ □ □
	LARGE      SMALL
COLLISION SIZE	■ ■ ■ ■ □ □ □ □
LIFE	3
>EXIT	
SELECT WITH SERVICE BUTTON AND PRESS TEST BUTTON	

- GAME DIFFICULTY ( Default setting: 4)  
Alters difficulty level of the game. Choose from eight levels.
- BOSS DIFFICULTY (Default setting: 4)  
Alters difficulty level of BOSS battles for each stage. Choose from eight levels.
- SHIFTING DIFFICULTY (Default setting: 4)  
Alters rate at which level of difficulty increases as the game progresses. Choose from eight levels.
- COLLISION SIZE (Default setting: 4)  
Alters collision impact of enemy characters that appear throughout the game. Choose from eight levels.
- LIFE (Default setting: 4)  
INITIAL LIFE (Number of lives given to players at the start of the game). Players can be given from three to eight initial lives.

Changes to settings are not enabled until Test Mode is exited. After changing settings, be sure to exit Test Mode.

After changing the settings, select the EXIT and press the TEST Button to return to the Game Test Menu screen.

#### ④ GUN ADJUSTMENT



Although the Front Sight and the Rear Sight are attached to this Gun (Rod) Controller, it is not for uniting aim like an actual gun. Even if adjusted using these Sights, the aiming direction is not exact.

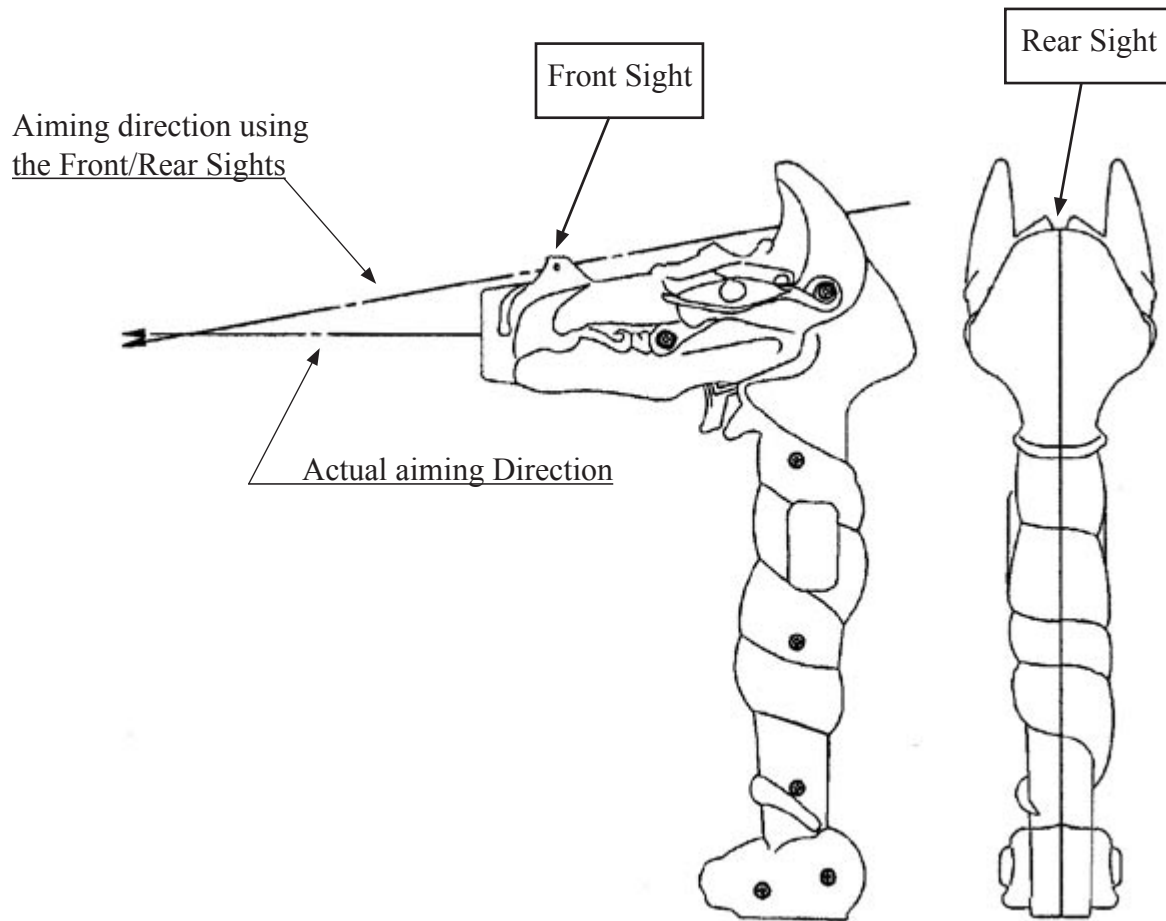

Select GUN ADJUSTMENT to display the following screen. Five aiming correction values (screen center, right limit, left limit, top and bottom) can be set from this screen. Set the five correction values in the following way: Aiming the Gun Controller in the specified direction, select 1P using the 1P Start Button and 2P using the 2P Start Button. When the Gun Controller is in the desired position, pull the trigger to set the new values.

## <GUN ADJUSTMENT Screen>

PLAYER 1		PLAYER 2	
OLD: NOW		OLD: NOW	
>RIGHT	aa bb	>RIGHT	aa bb
LEFT	aa bb	LEFT	aa bb
TOP	aa bb	TOP	aa bb
BOTTOM	aa bb	BOTTOM	aa bb
CENTER X	aa bb	CENTER X	aa bb
Y	aa bb	Y	aa bb
DEFAULT		DEFAULT	
CHECK		CHECK	

SELECT WITH START BUTTON  
AND PULL TRIGGER

PRESS TEST BUTTON TO EXIT

SIGHT OUT

- **RIGHT aa bb**  
Sets the right horizontal limit correction value.  
The left indicator (aa) shows the previous value and the right indicator (bb) show the newly-input value.  
Point the Gun Controller at the right edge of the screen, aiming at the square mark, and pull the trigger to set the correction value. Vertical movement has no effect on the values in this case.
- **TOP aa bb**  
Sets the upper vertical limit correction value.  
The left indicator (aa) shows the previous value and the right indicator (bb) show the newly-input value.  
Point the Gun Controller at the upper edge of the screen, aiming at the square mark, and pull the trigger to set the correction value. Horizontal movement has no effect on the values in this case.
- **CENTER X aa bb**  
Y aa bb  
Sets the center correction value.  
X indicates the horizontal and Y indicates the vertical. The left display (aa) shows the previous value and the right display (bb) shows the newly-input value.  
Point the Gun Controller at the center of the screen, aiming at the square mark, and pull the trigger to set the correction value.

- **LEFT aa bb**  
Sets the left horizontal limit correction value.  
The left display (aa) shows the previous value and the right display (bb) shows the newly-input value.  
Point the Gun Controller at the left edge of the screen, aiming at the square mark, and pull the trigger to set the correction value. Vertical movement has no effect on the values in this case.
  
- **BOTTOM aa bb**  
Sets the lower vertical limit correction value.  
The left display (aa) shows the previous value and the right display (bb) shows the newly-input value.  
Point the Gun Controller at the lower limit of the screen, aiming at the square mark, and pull the trigger to set the correction value. Horizontal movement has no effect on the values in this case.
  
- **DEFAULT**  
Return correction values to their default settings.
  
- **CHECK**  
Select CHECK and point the Gun Controller at the screen. Use the two round cursors that appear at the top of the screen (red for Player 1 and blue for Player 2) to check aim.
  
- **SIGHT OUT**  
SIGHT OUT message appears when you point the Gun Controller to outside the screen.

Changes to settings are not enabled until the Test Mode is exited. After changing settings, be sure to exit Test Mode.

After changing the settings, select EXIT and press the TEST Button to return to the Game Test Menu screen.



## ⑤ BOOKKEEPING

Selecting BOOKKEEPING displays the two following screens of operating status data.

Pressing the TEST Button toggles between the first (BOOKKEEPING 1/2) and second (BOOKKEEPING 2/2) screens.

### <BOOKKEEPING Screen (1/2)>

BOOKKEEPING 1/2	
NUMBER OF GAMES	0
PLAY TIME	0D 00H 00M 00S
AVERAGE PLAY TIME	00H 00M 01S
LONGEST PLAY TIME	00H 00M 02S
SHORTEST PLAY TIME	00H 00M 03S

PRESS TEST BUTTON TO CONTINUE

- NUMBER OF GAMES: Indicates the total number of plays.
- PLAY TIME: Indicates the sum of the play times of Players 1 and 2.
- AVERAGE PLAY TIME: Total play time divided by number of games played.
- LONGEST PLAY TIME: Indicates the longest game play time.
- SHORTEST PLAY TIME: Indicates the shortest game play time.

Press the TEST Button to display the BOOKKEEPING 2/2 screen.

<BOOKKEEPING Screen (2/2)>

BOOKKEEPING 2/2		
TIME HISTOGRAM		
0M00S - 0M29S		0
0M30S - 0M59S		0
1M00S - 1M29S		0
1M30S - 1M59S		0
2M00S - 2M29S		0
2M30S - 2M59S		0
3M00S - 3M29S		0
3M30S - 3M59S		0
4M00S - 4M29S		0
4M30S - 4M59S		0
5M00S - 5M29S		0
5M30S - 5M59S		0
6M00S - 6M29S		0
6M30S - 6M59S		0
7M00S - 7M29S		0
7M30S - 7M59S		0
8M00S - 8M29S		0
8M30S - 8M59S		0
9M00S - 9M29S		0
9M30S - 9M59S		0
OVER 10M00S		0
0M30S - 0M59S		0
0M00S - 0M29S		0
0M30S - 0M59S		0

PRESS TEST BUTTON TO EXIT

PLAY TIME HISTOGRAM shows the number of plays and their respective play times. This histogram should be referred to when setting the Game Difficulty.

Press the TEST Button to return to the Game Test Menu screen.

## ⑥ BACKUP DATA CLEAR

Select BACKUP DATA CLEAR to clear the contents of BOOKKEEPING and Ranking Data.

### <BACKUP DATA CLEAR Screen>

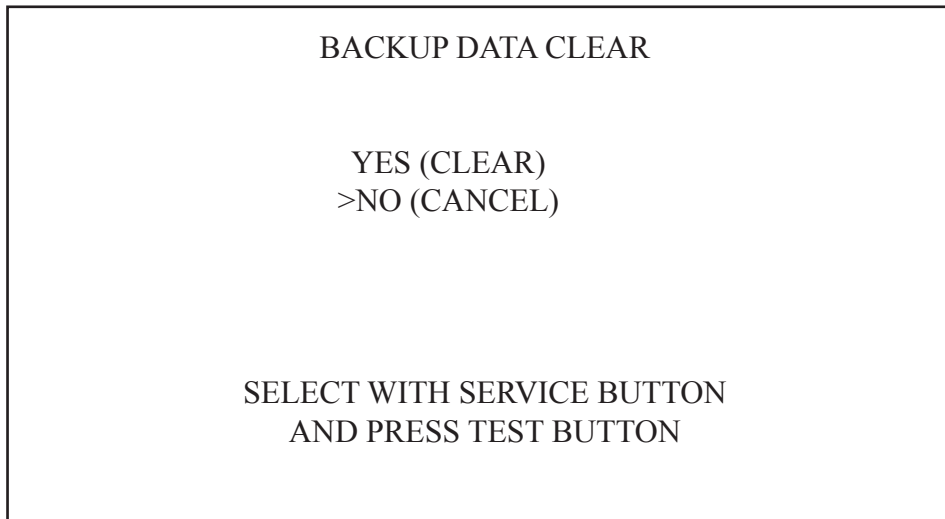

To clear data, use the SERVICE Button to move the cursor to YES (CLEAR) and then press the TEST Button.

When the data has been cleared, the message “COMPLETED” will be displayed.

Press the TEST Button again to return to the Game Test Menu screen.

Move the cursor to NO (CANCEL) and press the TEST Button to return to the Game Test Menu screen without clearing the data.

Note that this operation does not affect the settings of the GAME ASSIGNMENTS and the GUN ADJUSTMENT.

Using the BACKUP DATA CLEAR function from this screen will not affect coin/credit data. To clear coin/credit data, use the BACKUP DATA CLEAR function in SYSTEM TEST MODE.

⑦ LANGUAGE (For overseas version other than US, Australia, and Korea)

Select LANGUAGE to display the following screen and choose the language displayed on the screen message. Five languages (English/French/German/Italian/Spanish) are selectable. Default setting: English)

**<LANGUAGE Screen>**

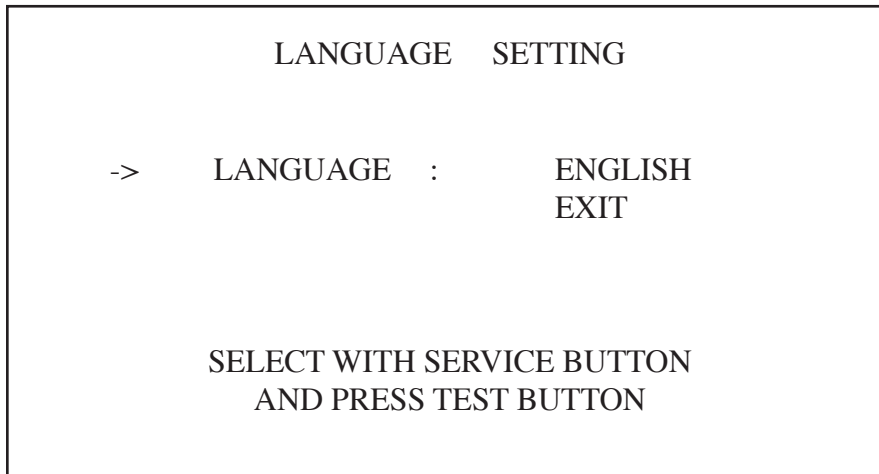

Use the SERVICE Button to move the cursor to LANGUAGE and press the TEST Button to choose your favorite language.

Move the cursor to EXIT and press the TEST Button to return to the Game Test Menu screen.

## 10. CONTROLLER



- In order to prevent an electric shock and short circuit, be sure to turn power off before performing work by touching the interior parts of the product.
- Be careful so as not to damage wirings. Damaged wiring can cause an electric shock or short circuit accident.
- Be very careful when soldering. Handling a soldering iron carelessly may result in a fire or a burn.



When securing the plastic-made parts, do not excessively fasten screws and nuts. Failure to observe this may damage the parts and cause injury due to fragments resulting from damage.

In the cases where the controller's operation is not satisfactory or the controller sight deviates from the direction in which the controller is pointed, the controller's interior parts may have been damaged. Replace the parts by disassembling the controller in the following procedure: Also, be sure to perform sighting check in the test mode when the controller parts are replaced.

### REPLACING THE MICROSWITCH

- ① Disassemble the controller.
- ② Pull out the microswitch from COVER RIGHT.
- ③ Take out the microswitch by removing the soldering from it.
- ④ Bend the new Microswitch Actuator as shown.
- ⑤ Solder the new microswitch and assemble the controller.
- ⑥ By operating the Trigger, check if the Microswitch can be turned ON/OFF correctly.

### REPLACING THE SENSOR UNIT

- ① Disassemble the controller.
- ② Remove the sensor unit from COVER.

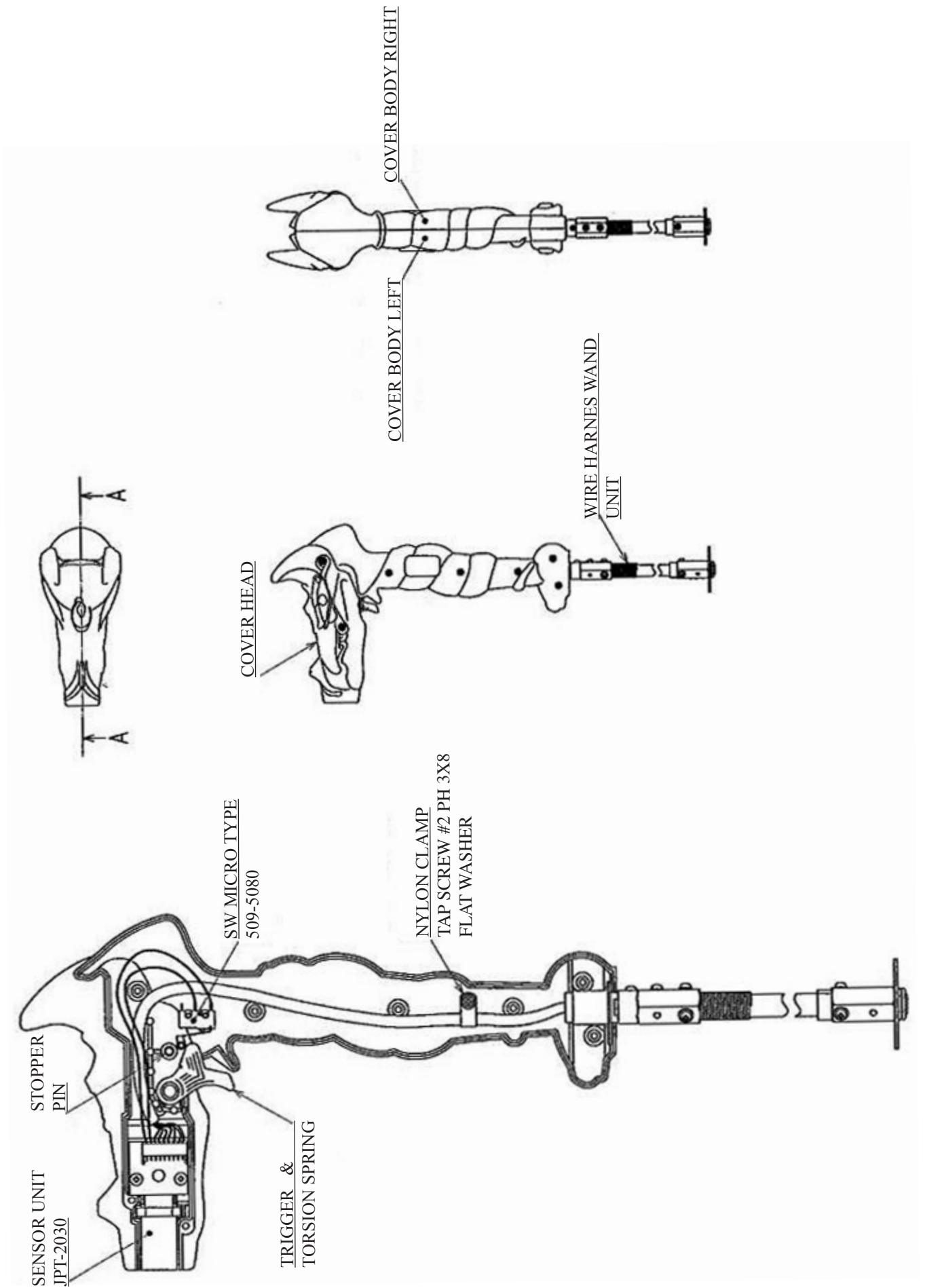

# 11. MONITOR

## 11 - 1 CAUTIONS AND WARNINGS CONCERNING THE SAFETY FOR HANDLING THE MONITORS

Before handling the monitors, be sure to read the following explanations and comply with the caution/warning instructions given below. Note that the caution/warning symbol marks and letters are used in the instructions.



Indicates that handling the monitors erroneously by disregarding this warning may cause a potentially hazardous situation, which could result in death or serious injury.



Indicates that handling the monitors by disregarding this caution may cause a potentially hazardous situation, which could result in personal injury and or material damage.



Indicates that access to a specific part of the equipment is forbidden.



Indicates the instruction to disconnect a power connector or to unplug.



- When performing such work as installing and removing the monitor, inserting and disconnecting the external connectors to and from monitor interior and the monitor, be sure to disconnect the power connector (plug) before starting the work. Proceeding the work without following this instruction can cause electric shock or malfunctioning.
- Using the monitor by converting it without obtaining a prior permission is not allowed. SEGA shall not be liable for any malfunctioning and accident caused by said conversion.



- **Primary side and Secondary side**  
The monitor's circuit which is divided into the Primary side and Secondary side, is electrically isolated. Do not touch the primary side, or do not touch both the primary side and the secondary side simultaneously. Failing to observe the instruction can cause electric shock and this is very dangerous. When making monitor adjustments, use a non-conductive driver and make adjustment without touching any part other than the Adjustment V. R. and knob. Also, be sure not to cause a short-circuit to the Primary side and Secondary side. If short-circuited, it can cause electric shock or malfunctioning, which is very dangerous.

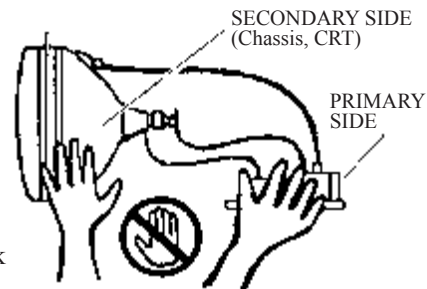

- **High-tension Voltage**  
Some of the parts inside monitor are subject to high-tension voltage in excess of 20,000 volts and very dangerous. Therefore, do not touch the monitor interior. Should soldering & paper wastes, etc. be mixed in the monitor interior, turn the power off so as not to cause malfunctioning or fire hazard.

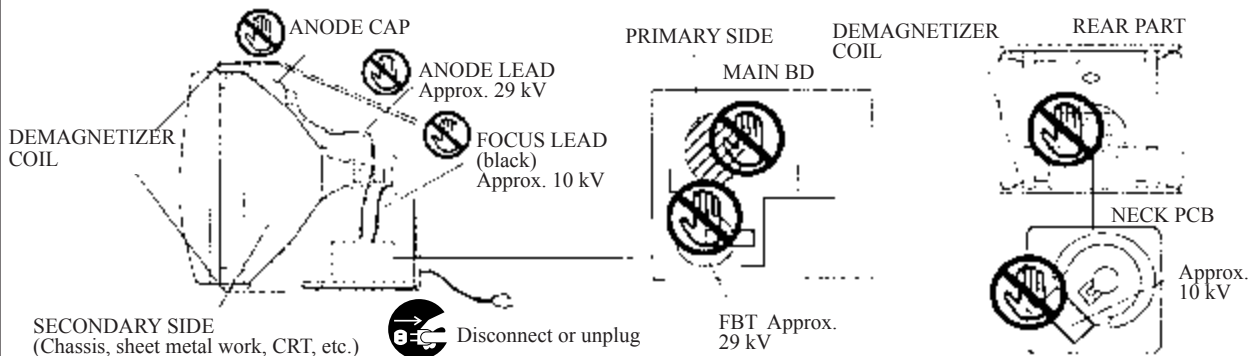

- **Connecting the CRT and PCB**  
For combining the CRT and PCB, use the specified part No. to maintain the status of adjustments made at the factory. The anode of the CRT itself will be accumulatively charged as time elapses, generating high-tension voltage which is very dangerous. The monitor should be used with the Chassis, CRT and PCB assembled. When repair, etc. is required at the time of malfunctioning, be sure to send it in an "as is assembled" condition. If these are disassembled, what's charged to said high tension voltage can be discharged, causing a very hazardous situation. Therefore, under no circumstances should it be disassembled.



**CAUTION!**

- **Static Electricity**

Touching the CRT surface sometimes causes you to slightly feel electricity. This is because the CRT surfaces are subject to static and will not adversely affect the human body.

- **Installation and removal**

Ensure that the Magnetizer Coil, FBT (Fly-Back Transformer), Anode Lead and Focus Lead are not positioned close to the sheet metal work's sharp edges, etc. and avoid damaging the insulated portions so as not to cause electric shock and malfunctioning. (For the name of parts, refer to the above Figures).





For the purpose of static prevention, special coating is applied to the CRT face of this product. To protect the coating, pay attention to the following points. Damaging the coating film can cause electric shock to the customers.

- Do not apply or rub with a hard item (a rod with pointed edge, pen, etc.) to or on the CRT surfaces.
- Avoid applying stickers, seals, etc. on the CRT face.
- Do not remove aluminum foils from the CRT corners. Removing the aluminum foils can cause static prevention effects to be lowered.

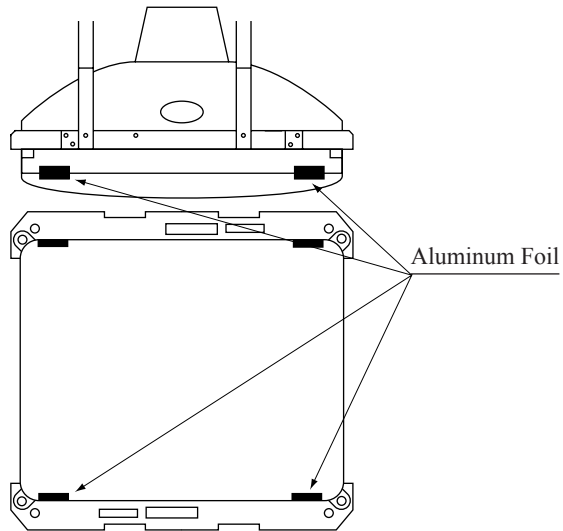

## 11 - 2 CAUTIONS TO BE HEEDED WHEN CLEANING THE CRT SURFACES



Use care when handling the glass made parts. If glass made parts are damaged, the glass fractions can cause injury.



- When cleaning the CRT, be sure to use a soft, dry cloth. Do not use chemicals such as thinner, benzene, etc.
- Apply anti-static agent, which prevents dust attachment, only to the CRT face.

Be sure to turn power off before cleaning the CRT.

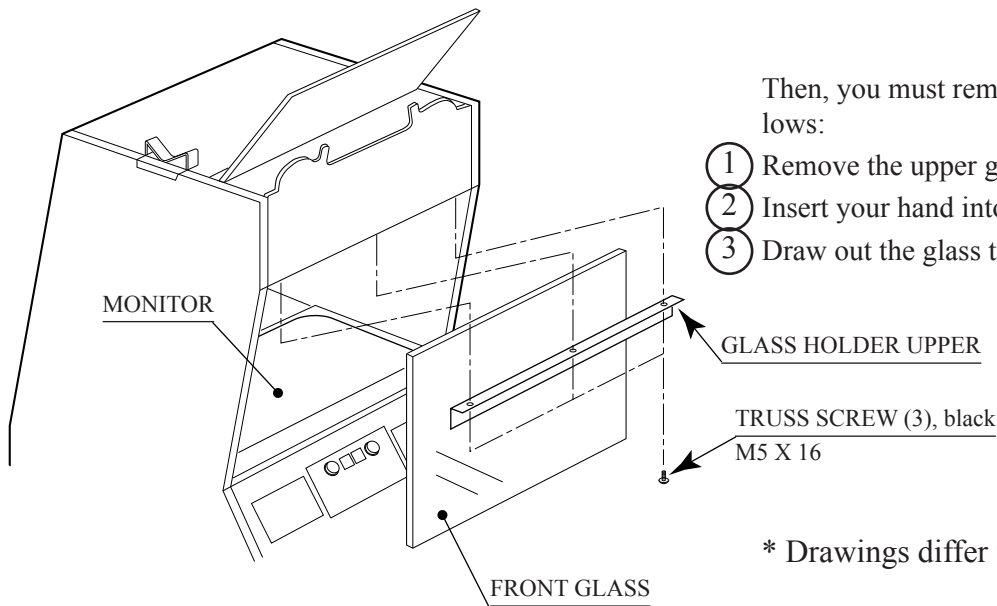

FIG. 11. 2 \*

\* Drawings differ from actual game.



- Monitor adjustments have been made at the time of shipment. Therefore, do not make further adjustment without a justifiable reason. Adjusting the monitor which contains high tension parts is a dangerous work. Also, an erroneous adjustment can cause deviated synchronization and image fault, resulting in malfunctioning.
- When making adjustment, utilize a resinous Alignment Rod. Servicing with bare hand or using conductive tools can cause electric shock.
- Be sure to perform appropriate adjustment of the monitor (projector). For operation of this machine, do not leave monitor's flickering or deviation as is. Failure to observe this can have a bad influence upon the players' or the customers' physical conditions.

Remove the back door at the rear of the cabinet, and the monitor adjustment knob appears.

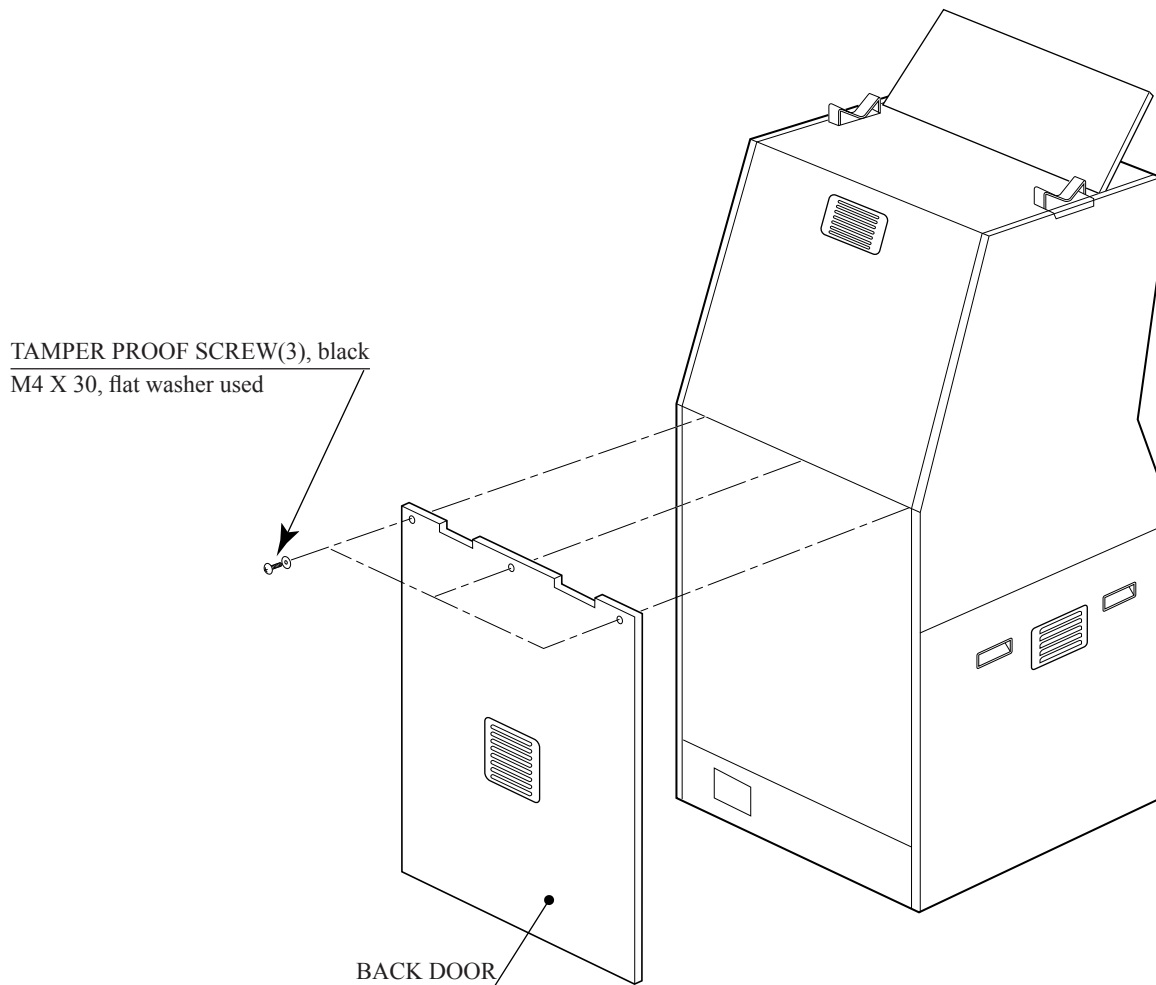
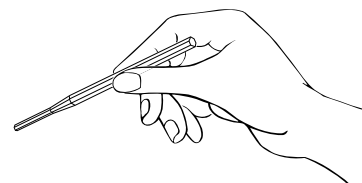
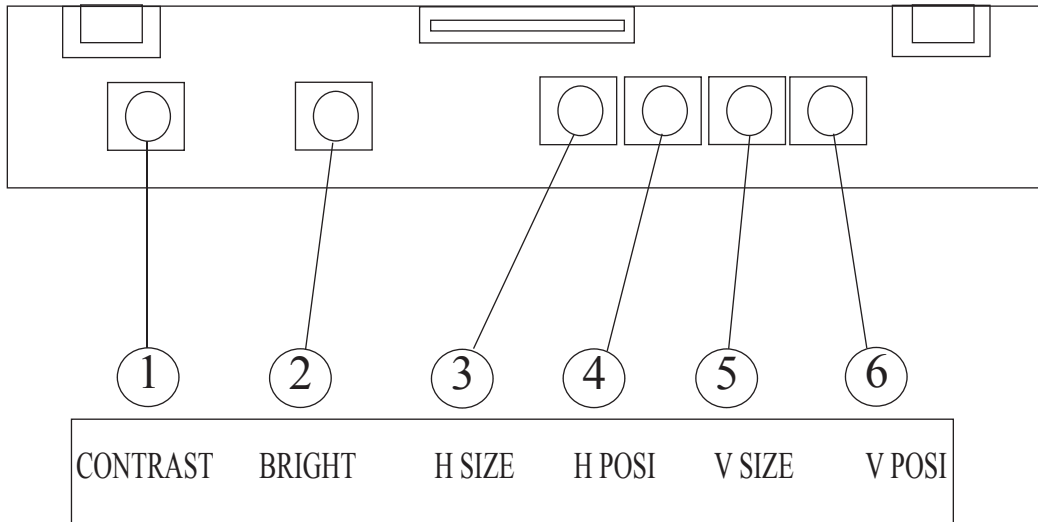

FIG. 11. 3 a



For adjustment, use a non conductive tool.

FIG. 11. 3 b



- ① **CONTRAST**..... Adjust image contrast.
- ② **BRIGHT**..... Controls screen brightness.
- ③ **H. SIZE**.....Controls horizontal screen size.
- ④ **H. POSI**.....Controls horizontal display position on screen.
- ⑤ **V. SIZE**.....Controls vertical screen size.
- ⑥ **V. POSI**.....Controls vertical display position on screen.

## 12. COIN SELECTOR

### HANDLING THE COIN JAM

If the coin is not rejected when the REJECT button is pressed, open the coin chute door and open the selector gate. After removing the jammed coin, put a normal coin in and check to see that the selector correctly functions.

### CLEANING THE COIN SELECTOR



- Remove and clean smears by using a soft cloth dipped in water or diluted chemical detergent and then squeezed dry.
- Never apply machine oil, etc. to the Coin Selector.
- After cleaning the Coin Selector, insert a regular coin in the normal working status and ensure that the Selector correctly functions.

The coin selector should be cleaned once every 3 months. When cleaning, follow the procedure below:

- 1 Turn the power for the machine OFF. Open the coin chute door.
- 2 Open the gate and dust off by using a soft brush (made of wool, etc.).
- 3 Remove and clean smears by using a soft cloth dipped in water or diluted chemical detergent and then squeezed dry.
- 4 Remove the CRADLE.  
When removing the retaining ring (E ring), be very careful so as not to bend the rotary shaft.
- 5 Remove stain from the rotary shaft and shaft receiving portions by wiping off with a soft cloth, etc.
- 6 After wiping off as per 5 above, further apply a dry cloth, etc. to cause the coin selector to dry completely.

### COIN INSERTION TEST

Once every month, when performing the Coin SW Test, simultaneously check the following:

- Does the Coin Meter count satisfactorily?
- Does the coin drop into the Cashbox correctly?
- Is the coin rejected when inserted while keeping the Reject Button pressed down?

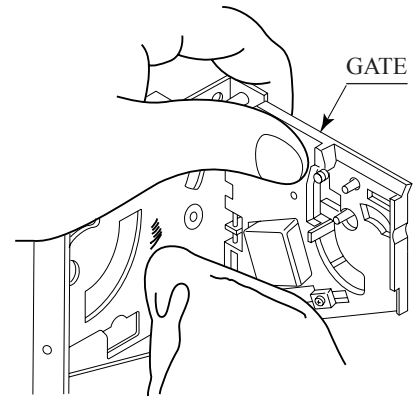

FIG. 12 a

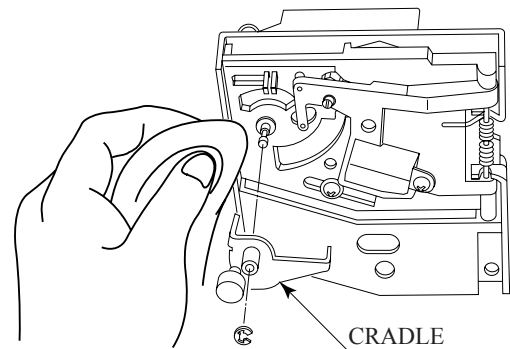

FIG. 12 b

Insert a coin while keeping the Reject Button pressed down and check if it is rejected.

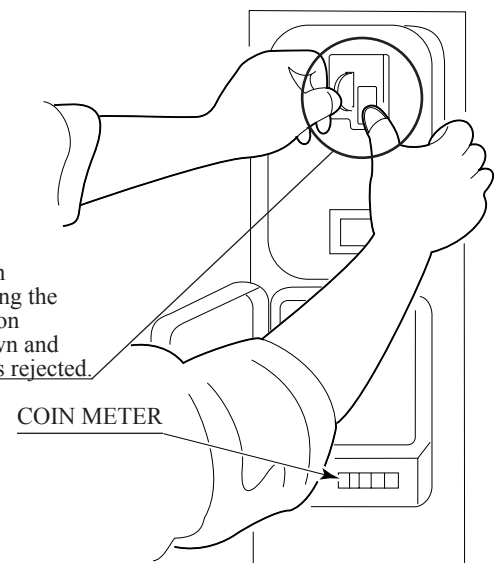
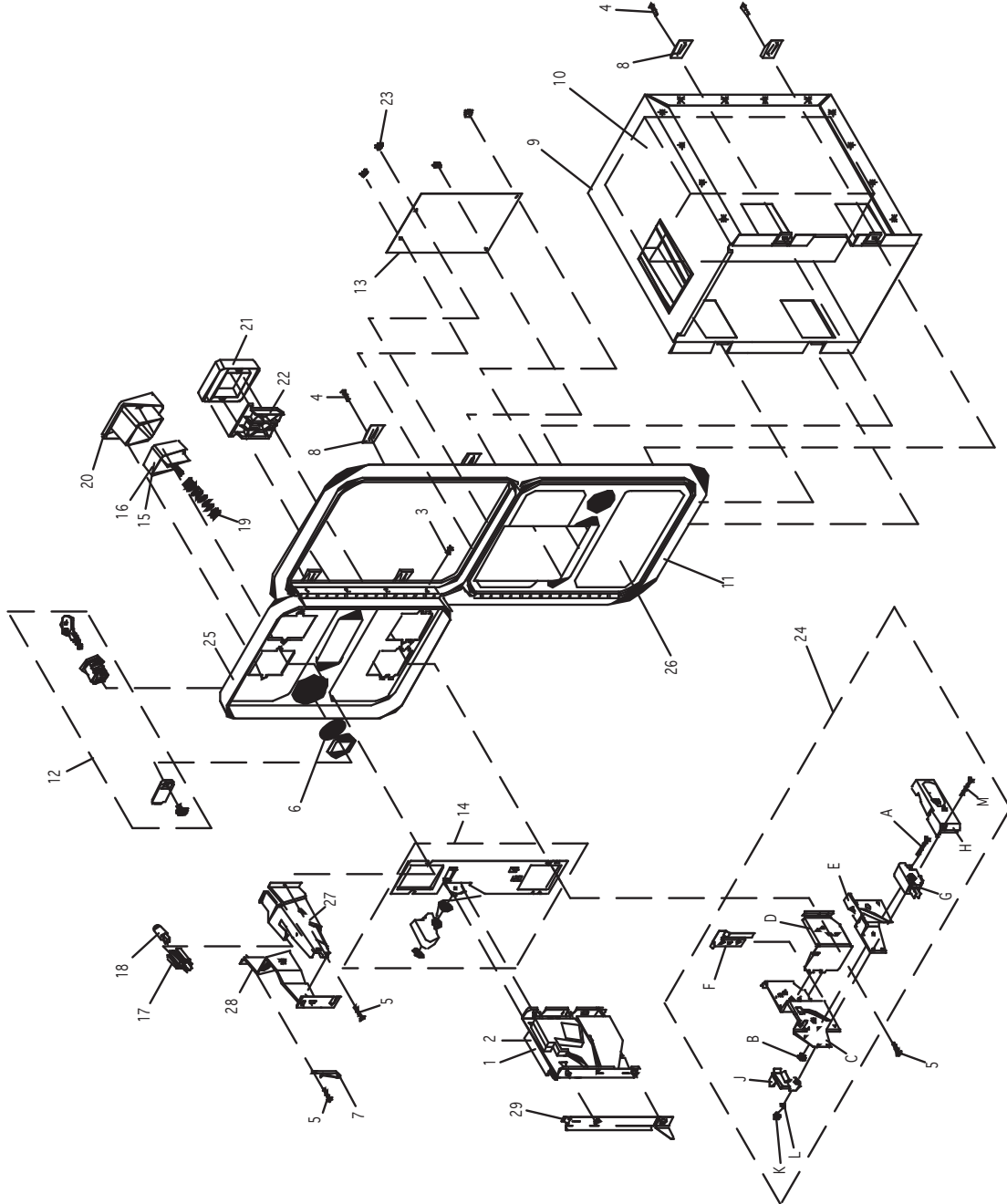

FIG. 12 c

WELLS-GARDNER  
ELECTRONICS CORPORATION  
2701 N. KILDARE CHICAGO, IL 60639  
1-800-336-6630  
WWW.WGEC.COM

WGD15-2110-01  
OVER/UNDER MINI DOOR  
2 ENTRIES WITH BILL  
VALIDATOR BOTTOM DOOR  
& SPECIAL ENCLOSURE



#	W.G. PART #	DESCRIPTION
1	812-4150-011	S-7 US 25¢ COIN MECH LEFT
2	812-4050-011	S-10 US \$1 COIN MECH RIGHT
3	890-1002-00	HINGE SCREW
4	890-1003-00	CLAMP SCREW
5	890-1017-00	SCREW TRILOBULAR
6	890-1019-00	WASHER INTERNAL TOOTH 3/4"
7	890-1300-00	KEYHOOK
8	891-0514-00	CLAMP LK 5/8" CABINET
9	025X3711-001	ENCLOSURE W/CHUTE
10	025X3712-001	METAL CASHBOX
11	891-0509-162	DOUBLE FRAME
12	891-0547-00	LOCK SINGLE BIT
13	891-0100-4016	COVER PLATE
14	891-1008-107	BASE PLATE ASSEMBLY
15	891-1113-03	E/R BUTTON US 4x25¢ \$1 LEFT
16	891-1113-011	E/R BUTTON US \$1 COIN RIGHT
17	891-1117-00	LAMP HOLDER
18	891-1118-00	LAMP WEDGE BASE 6 VOLT
19	891-1121-00	SPRING, E/R BUTTON
20	891-1311-16	BUTTON BEZEL, NYLON
21	891-1312-16	REJECT BEZEL, NYLON
22	891-1109-16	REJECT FLAP
23	020X1877-005	NUT KPS #6-32 X 3/16 HEX
24	891-2216-16	MICROSWITCH ASSEMBLY
24A	890-1007-00	SCREW FLAT HEAD M/S
24B	890-1206-02	KEP NUT
24C	891-1105-01	REJECT CUP SIDE PLATE
24D	891-1106-00	REJECT CUP BASE PLATE
24E	891-1107-00	BRACKET, MICROSWITCH
24F	891-1110-00	ADJUSTER, COIN
24G	891-1116-16	MICROSWITCH BLACK - MED.
24H	892-1002-07	COVER, PLASTIC
24K	892-1002-08	CLIP, SNAP-ON
24L	892-1002-09	ELASTIC SNAP NUT
24M	892-1002-11	SLEEVE, SNAP-ON
25	891-0604-16	SCREW, PAN HEAD
26	891-0614-16	MINI DOOR 2 ENTRIES
27	892-1002-01	MINI DOOR W/DRY C/O
28	892-1002-021	BRACKET, LAMP SIDE
29	892-1002-10	BRACKET, HOLD DOWN

Tom Happ  
 tom.happ@happcontrols.com  
 Happ Controls  
 106 Garlisch Drive  
 Elk Grove, IL. 60007  
 Ph. 847-593-6161 ext. 107  
 Fx. 847-956-2091

Visit our website <http://www.happcontrols.com>

**EXCLUSIVE!**

Custom  
 "Guardian"  
 Security Hasp  
 available  
 to protect your  
 dollars,

**GUARDIAN**

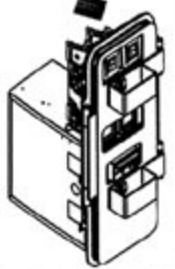

MECH HOLDER PARTS	
MECH HOLDER	42-3319-00
W/COIN SWITCH	42-7355-00
MECH HOLDER	42-7355-00
W/O COIN SWITCH	42-7087-00
COIN SWITCH	42-7087-00
SCREW FOR COIN SWITCH	43-0136-00
METAL CLIP	42-7338-91
THUMBSCREW FOR METAL CLIP	42-7338-90

OTHER COMPONENTS	
UPPER DOOR	42-3216-00
LOWER DOOR	42-3145-16
FRAME	42-3272-00
DOOR SCREWS	43-0183-00
DOOR & FRAME	42-3227-00

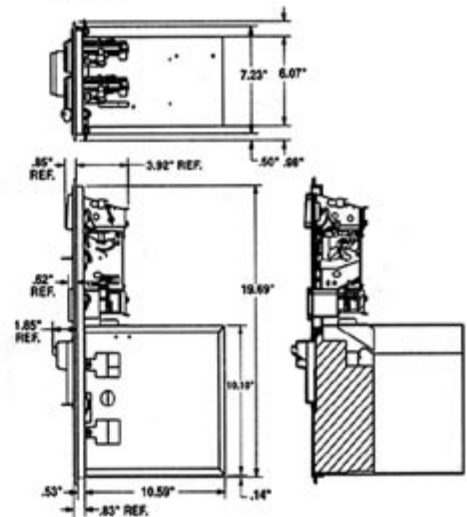
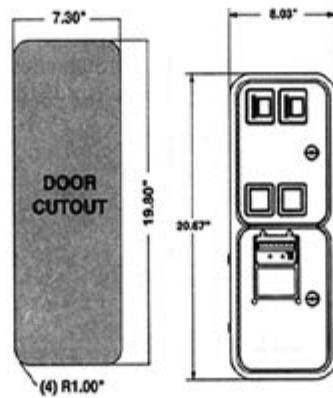
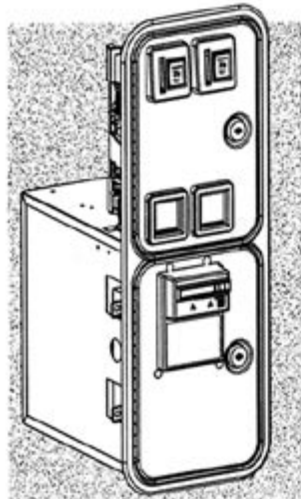
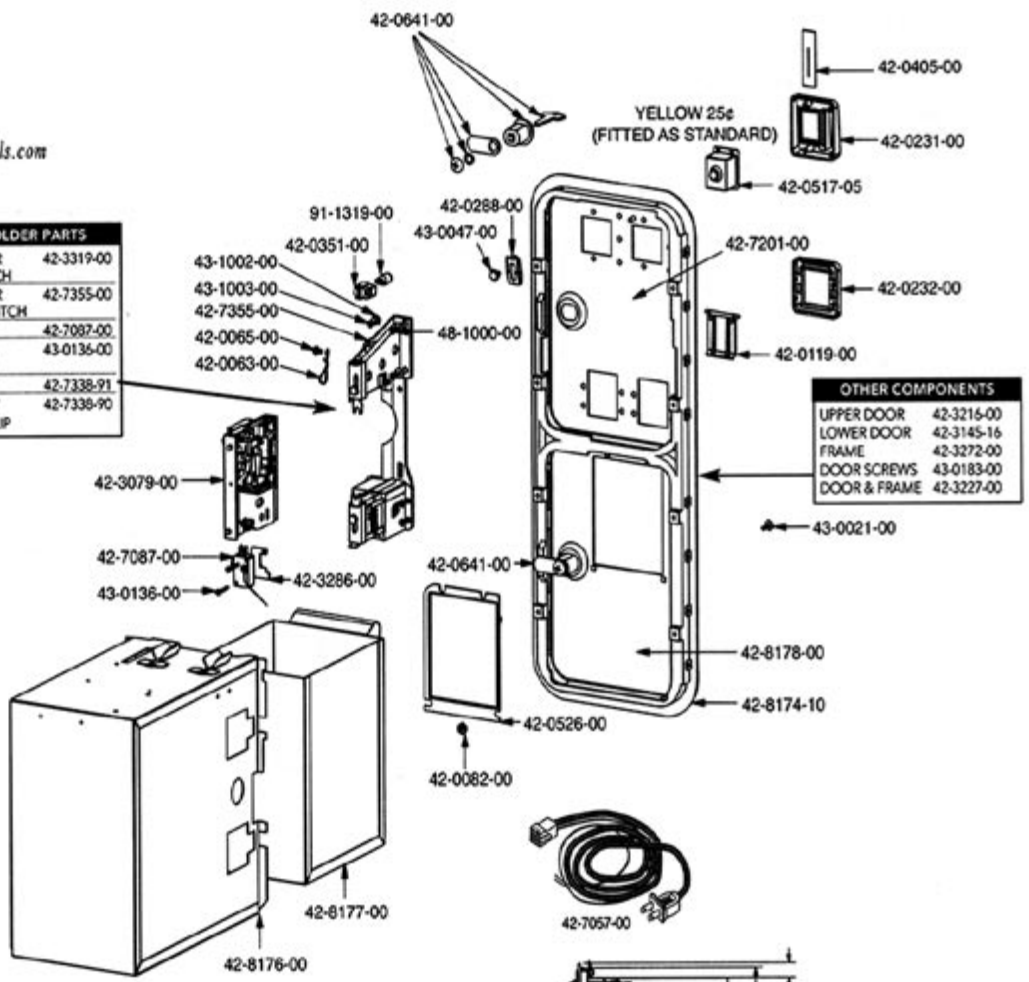

## OPTIONAL DOLLAR BILL ACCEPTOR

- THE COIN DOOR ASSEMBLY USED ON **THE MAZE OF KINGS STANDARD** COMES EQUIPPED TO ACCEPT A DOLLAR BILL ACCEPTOR. ALL NEEDED WIRING CONNECTIONS ARE CONVENIENTLY LOCATED INSIDE THE GAME FOR THIS APPLICATION.
- THE COIN DOOR CAN ACCOMMODATE THE FOLLOWING VALIDATOR(S):

FORWARD-MOST  
HOLE POSITION

Mars 2000 series

\*\*42-1155-00                      MARS VALIDATOR \$1, 2, 5 300 CAP

The frame and cashbox enclosure on this coindoor has been modified to accommodate a Mars 2000 series upstacker. A 2000 series stacker can be added by simply removing the cut-out plate. This one entry door can be ordered through Happ Controls or one of Happ Controls authorized distributors. The part number is 40-6000-10EX. The Mars stacker can be obtained through an authorized Mars distributor.

Note: Your game may have either Happ Controls Coin Door Assembly or the Wells Gardner Coin Door Assembly (not shown).

\*\*Happ part number

Security Locking Bar/Bracket Set Part No.# 999-0966

Modified Cash Box (For use when DBA installed)  
Part No. # 999-1106

Plastic Cash Box - Full Size Part No. # 999-1177

# 13. REPLACING THE FLUORESCENT LAMP, AND LAMPS



- When performing work, be sure to turn power off. Working with power on can cause electric shock and short circuit hazards.
- The Fluorescent Lamp, when it gets hot, can cause burn. Be very careful when replacing the Fluorescent Lamp.
- Be sure to use lamps of the designated rating. Using lamps of undesignated rating can cause a fire or malfunctioning.



- To perform work safely and securely, be sure to prepare a step which is in a secure and stable condition. Performing work without using the step can cause violent falling down accidents.
- Be careful when handling the plastic made parts. Failure to observe this may cause injury due to damage or fragments resulting from damage.

## INSIDE THE BILLBOARD

- 1 Disconnect the power.
- 2 Remove the 3 truss head screws from the bottom of the billboard, and draw out the billboard case toward you. Be careful not to draw out too much; otherwise it may drop down and eventually cause an accident.
- 3 Remove the 4 truss head screws, and thereby remove the lamp cover B and billboard plate.
- 4 Remove the 2 countersunk screws, and thereby remove the lamp cover A. Now, replace the fluorescent light with a new one.

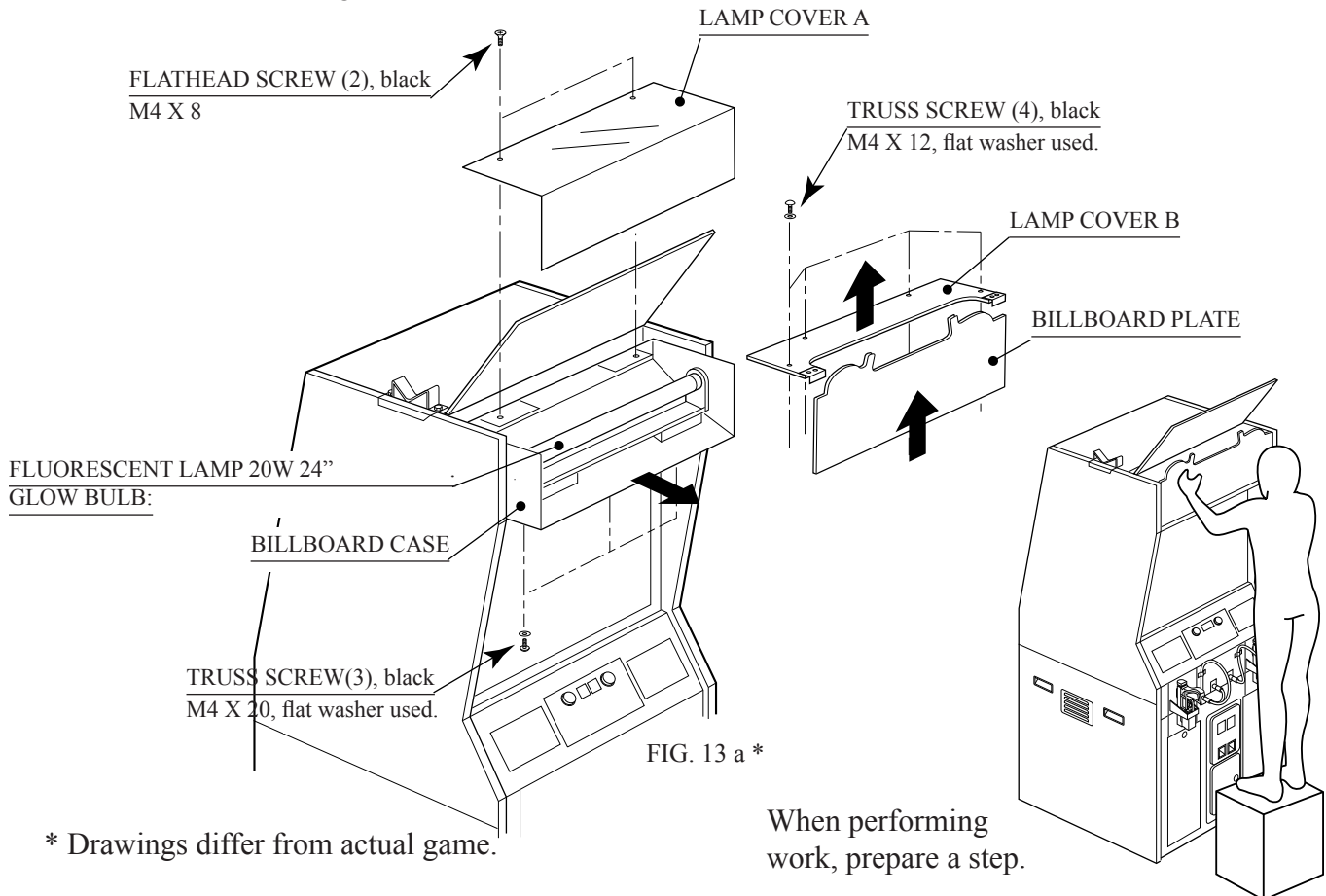



## REPLACING THE LAMP

- ① Take out the 6 truss screws and remove the Switch Panel. At this time, be careful so as not to damage wiring.

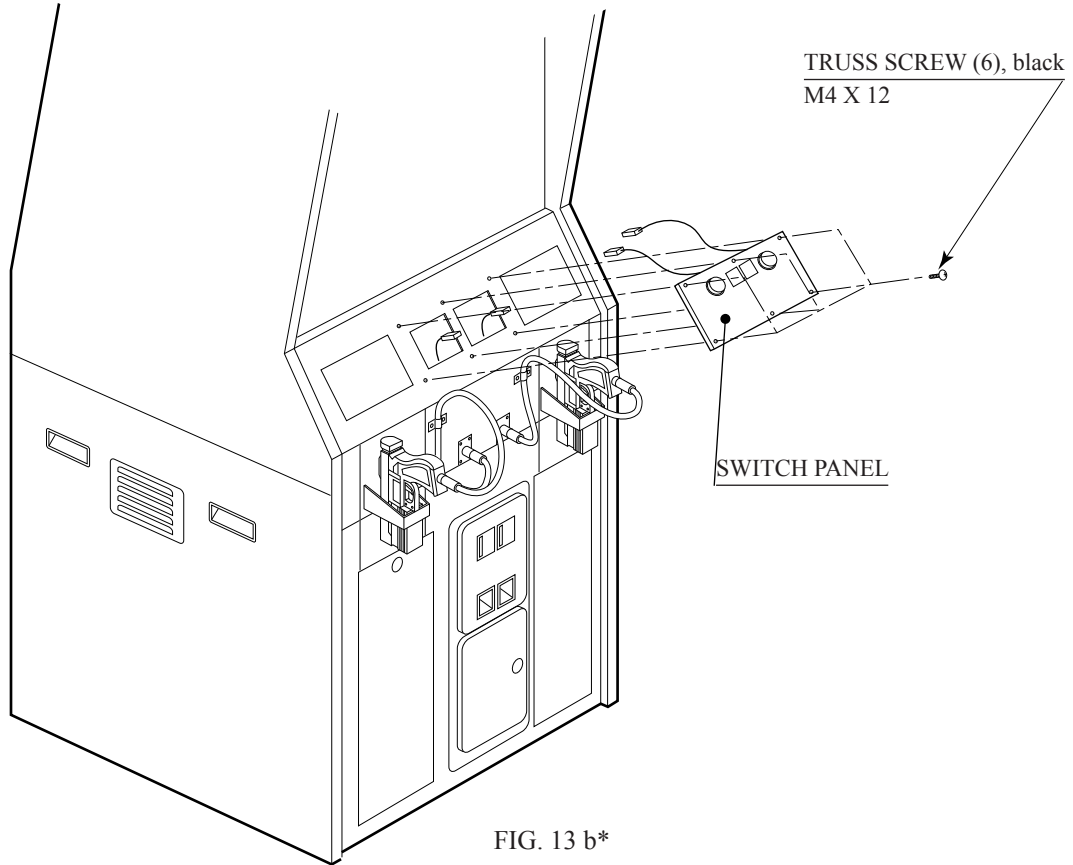

\* Guns are different in actual game.

- ② Hold both sides of the switch portion with fingers and pull out from the button's base portion. At this time, be careful so as not to damage the wiring connected to the switch.
- ③ The lamp is positioned at the end of the switch portion. Pull out the lamp straight without turning it.

WEDGE BULB, 6V 3W  
390-5160

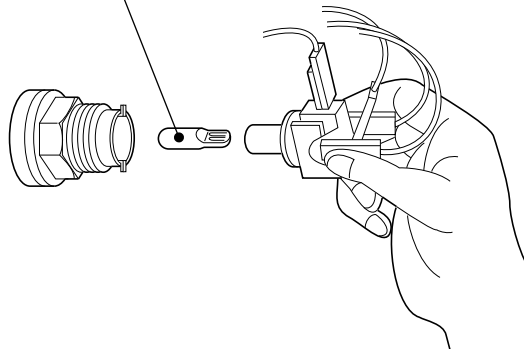

## 14. PERIODIC INSPECTION TABLE

The items listed below require periodic check and maintenance to retain the performance of this machine and to ensure safe business operation.

When handling the controller, the player will be in direct contact with it. In order to always allow the player to enjoy the game, be sure to clean it regularly. Also, it is advisable to provide wet tissue, etc. available for player use.



- Be sure to check once a year to see if Power Cords are damaged, the plug is securely inserted, dust is accumulated between the Socket Outlet and the Power Plug, etc. Using the product with dust as is accumulated can cause fire and electric shock hazards.
- Periodically once a year, request the place of contact herein stated or the Distributor, etc. where the product was purchased from, as regards the internal cleaning. Using the product with dust as is accumulated in the interior without cleaning can cause a fire or accident. Note that cleaning the interior parts can be performed on a pay-basis.

TABLE 14

	Item	Interval	Reference
CABINET	Check Adjusters'contact with surface.	Daily	3
CONTROLLER	Cleaning	As necessary	
	Sight check	Weekly	9,10
	Check SWes.	Monthly	9,10
COIN CHUTE DOOR	Check COIN SW.	Monthly	9
	Coin insertion test.	Monthly	12
	Cleaning of COIN SELECTOR.	Trimonthly	12
MONITOR	Cleaning CRT face.	Weekly	11
	Check adjustments.	Monthly	6,9,11
FRONT GLASS,MIRROR	Cleaning	Weekly	See next page.
GAME BD	Check settings.	Monthly	9,*GD-ROM
	MEMORY TEST.	Monthly	9,*GD-ROM
INTERIOR	Cleaning	Annually	See above.
POWER SUPPLY PLUG	Inspection and cleaning		
Cabinet surfaces	Cleaning	As necessary.	See below.

\*The 'GD-ROM' above indicates the GD-ROM SERVICE MANUAL

### CLEANING THE CABINET SURFACES

When the cabinet surfaces are badly soiled, remove stains with a soft cloth dipped in water or diluted (with water) chemical detergent and squeezed dry. To avoid damaging surface finish, do not use such solvents as thinner, benzine, etc. or abrasives, bleaching agent and chemical dustcloth.

## CLEANING THE FRONT GLASS AND MIRROR

When cleaning, be sure to comply with the following CAUTION and instructions so as to ensure that the front glass and mirror are not damaged.



CAUTION!

Use care when handling glass made parts. When the glass is damaged, fragments of glass can cause injury.



IMPORTANT!

- Be sure to use the accessory glass cleaner or high-efficiency alkaline cleansing water. To avoid damaging the glass surfaces, do not use solutions such as thinner and alcohol, or abrasives, nor bleaching agents.
- Use a soft cloth.
- When removing an attached large particle of dust (or foreign matter), do not rub with a cloth.

Remove the front glass when cleaning the front glass and mirror. First, remove GLASS HOLDER UPPER only. Then, put your hand through the square hole in the back side of GLASS HOLDER UPPER, and pull the front glass toward you.

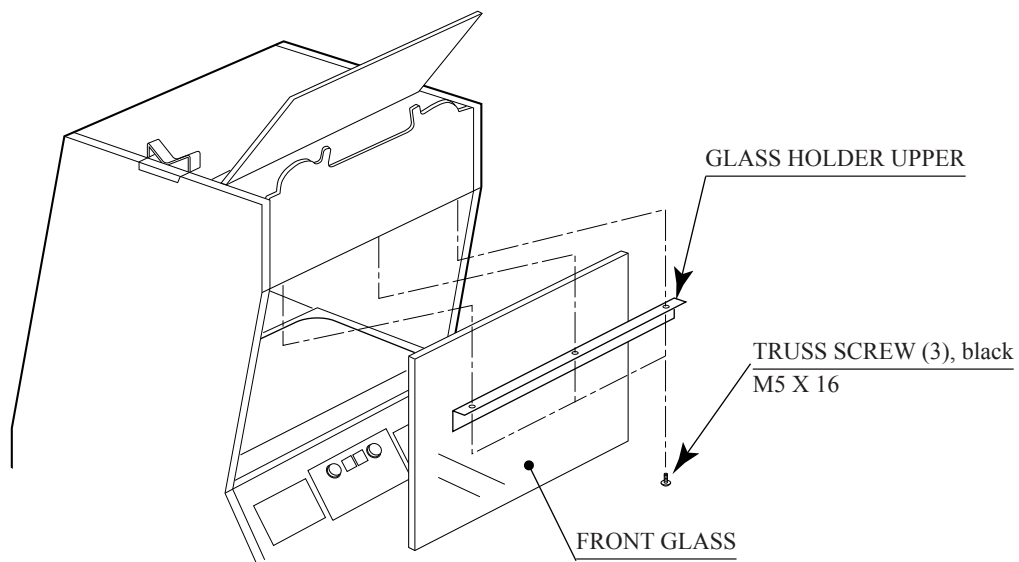

FIG. 14 \*

\* Drawings differ from actual game.

# 15. TROUBLESHOOTING



- In order to prevent electric shock and short circuit, be sure to turn power off before performing work.
- Be careful so as not to damage wirings. Damaged wiring can cause electric shock or short circuit.
- After removing the cause of the functioning of the Circuit Protector, reinstate the Circuit Protector. Depending on the cause of the functioning, using the Circuit Protector as is without removing the cause can cause generation of heat and fire hazard.

In case a problem occurs, first check wiring connector connections.

TABLE 15 a

PROBLEMS	CAUSE	COUNTERMEASURES
When the main SW is turned ON, the machine is not activated.	The power is not ON.  Incorrect power source/voltage.  AC UNIT CIRCUIT PROTECTOR functioned due to instantaneous overcurrent.	Firmly insert the plug into the outlet.  Make sure that the power supply/voltage are correct.  First, remove the cause of overcurrent and reinstate the circuit protector to its original status (see 4 , Section 6, Refer to the following).
The color on MONITOR screen is incorrect.	Image adjustment is inappropriate.	Adjust appropriately (see Sec.11).
The on-screen image of the monitor sways and or shrinks.	The power source and voltage are not correct.	Make sure that the power supply and voltage are correct.

## CIRCUIT PROTECTOR

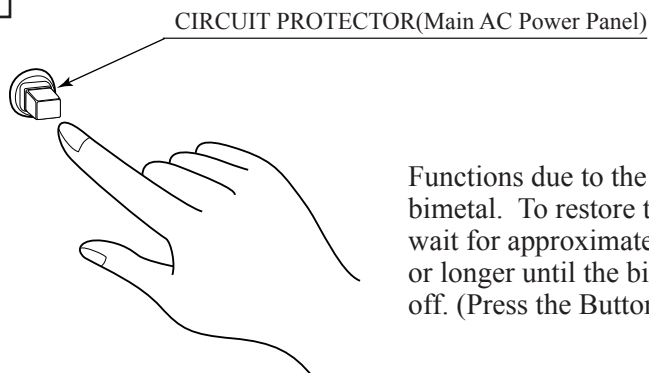

Functions due to the activation of bimetal. To restore the function, wait for approximately one minute or longer until the bimetal cools off. (Press the Button.)

FIG. 15 a

TABLE 15 b

PROBLEMS	CAUSE	COUNTERMEASURES
No sound is emitted.	Sound volume adjustment is not appropriate.  Board and Amplifier malfunctioning.	Adjust sound volume (see Sec. 9).  Perform the sound test and confirm (see GD-ROM SERVICE MANUAL).
Controller sighting is not satisfactory.	Due to environmental changes, etc., sighting became inappropriate.  LED BD malfunctioning.  Sensor Unit malfunctioning.  LED BD, Front Glass, and Mirror are soiled.	Perform sighting adjustment in the test mode (see Sec. 9).  Check to ensure that the LED lights up. If it does not light up, replace (see next page).  Replace the Sensor Unit (see Sec.10).  Wipe off soiled surfaces (see Sec. 14 and next page).
During game play, the Controller is not operable for shooting.	Malfunctioning of microswitch.  Malfunctioning of LED BD.  Malfunctioning of Sensor Unit.	Check for ON and OFF in the INPUT test and if it is not functioning, replace the microswitch (see Sec.10).  Check if the LED is lit, and if it is not lit, replace (see next page).  Replace the Sensor Unit.
The Fluorescent lamp does not light up.	The Fluorescent tube is burnt out.	Replace the Fluorescent tube (see Sec. 13).
The Lamp does not light up.	Lamp malfunctioning.	Replace the Lamp (see Sec. 13).

## REPLACEMENT OF LED BD

If the light emission of 2 LED's can not be seen, the fault or malfunctioning may be considered. Replace by using the following procedure. Also, when wiping off the soils, remove the ASSY SENSOR as per the same procedure.

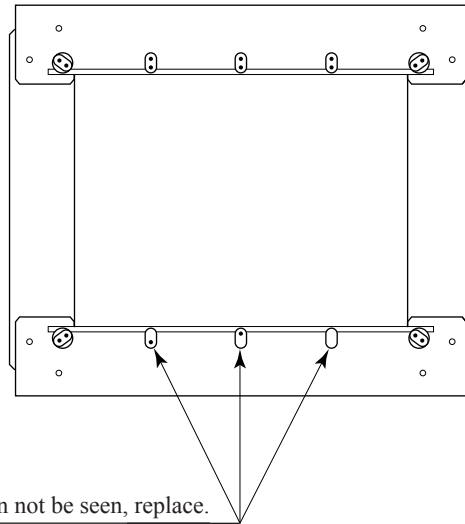

If light emission from the 2 LED's can not be seen, replace.

FIG. 15 b

- ① Turn power off.
- ② Remove the Back Door.
- ③ Disconnect the ASSY SENSOR CONNECTOR.
- ④ Unclamp the grounding cable. Remove the hexagon head nut, and remove a round grounding terminal from a screw shank.
- ⑤ Pull out the ASSY SENSOR.

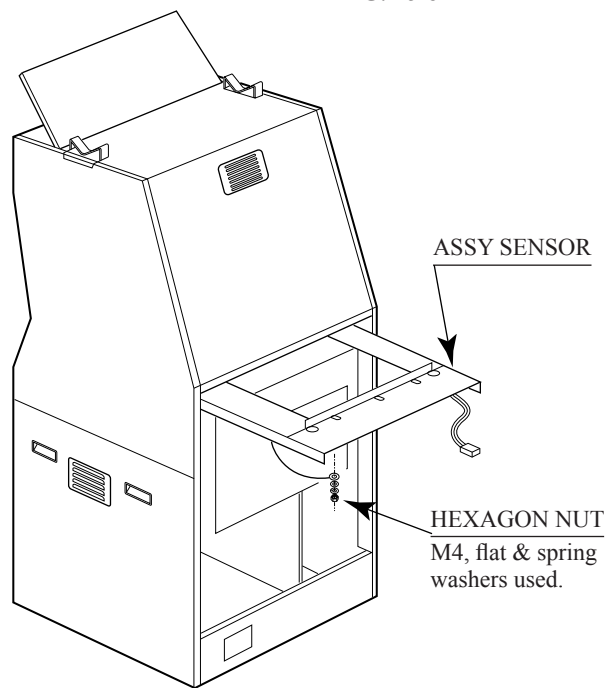

FIG. 15 c

- ⑥ Disconnect the connector from the both ends of the LED BD which shows defects.
- ⑦ Take out the 2 U Nuts to remove and replace the LED BD.

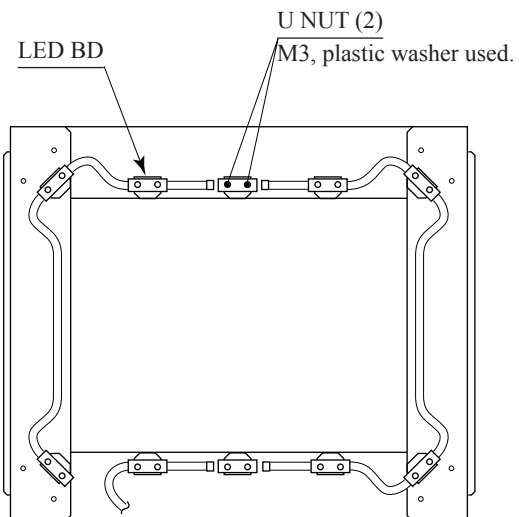

FIG. 15 d

## 16. GAME BOARD



- In order to prevent electric shock and short circuit hazards, be sure to turn power off before performing work.
- Be careful so as not to damage wirings. Damaged wiring can cause fire, electric shock or short circuit.
- Do not expose the Game BD, etc. without a good reason. Failure to observe this can cause electric shock hazard or malfunctioning.



- In this product, setting changes are made during the test mode. The Game BD need not be operated. Use the Game BD, etc. as is with the same setting made at the time of shipment so as not to cause electric shock and malfunctioning.
- The electronic parts on the IC Board may be damaged due to human body's static electricity. Before performing IC Board related work, be sure to discharge physically accumulated statics by touching grounded metallic surfaces, etc.

### 16 - 1 REMOVING THE GAME BOARD

- ① Turn off the main switch to disconnect the power.
- ② Unlock the front-left door, and thereby remove the door from the cabinet.

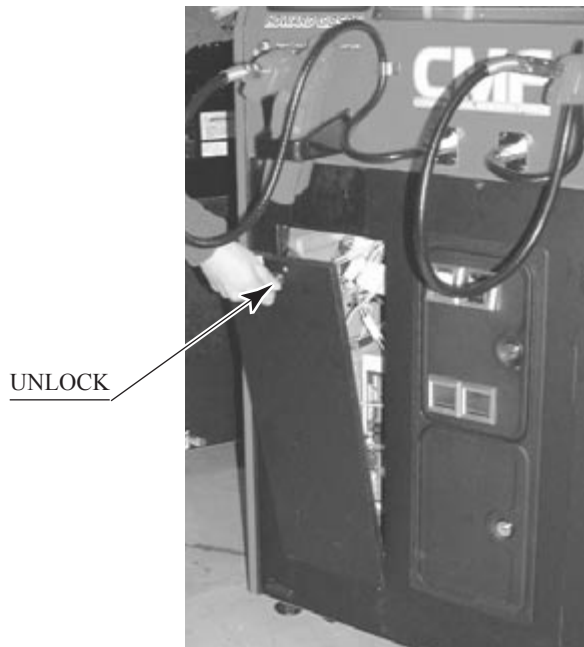

PHOTO 16. 1 a\*

\* Guns are different in actual game.

- ③ Take out the ASSY MAIN BD (with the NAOMI board) from the cabinet. Remove the 7 connectors from the upper section of the rear of the door.

Disconnect the connector.



PHOTO 16. 1 b\*

- ④ Remove the D-SUB connector from the filter board (a part of the NAOMI board on the ASSY MAIN BD). Unclamp the cable with the D-SUB connector.



D-SUB connector

PHOTO 16. 1 c\*

\* Guns are different in actual game.



- ⑤ Remove the 2 wing bolts that fix the ASSY MAIN BD's base (a wooden base).
- ⑥ Take out the ASSY MAIN BD from the cabinet. In this instance, be careful not to catch the wires on or in the parts.

WING BOLT (2)  
M4 X 30, flat washer used

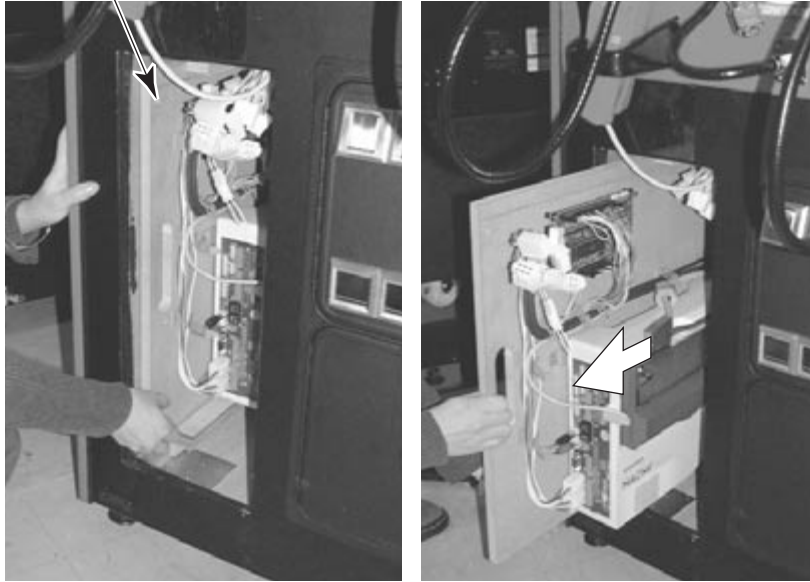

\* Guns are different in actual game.

PHOTO 16.1 d\*

- ⑦ Place the ASSY MAIN BD on a flat horizontal surface.
- ⑧ Remove all the connectors from the filter board on the NAOMI board. Also remove the GD cable connector from the DIMM board.
- ⑨ Remove the 4 screws that fix the NAOMI game board.

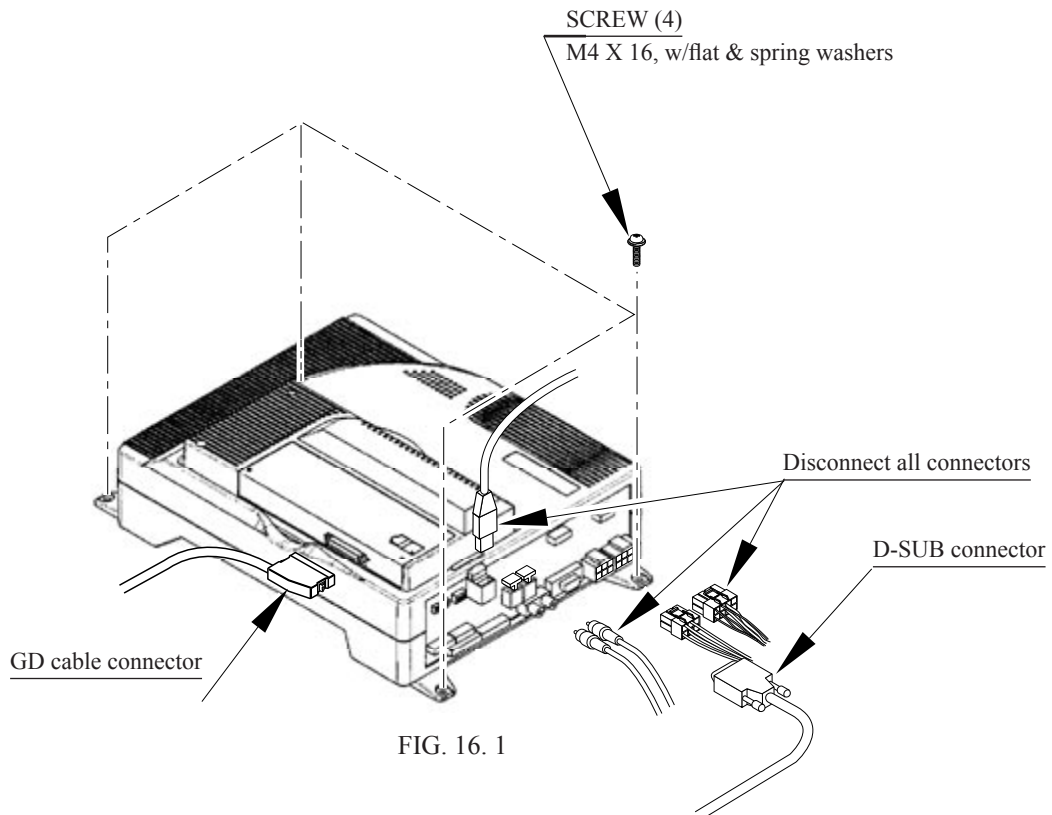

FIG. 16.1

## How to Remove the GD-ROM Drive

Take out the ASSY MAIN BD from the cabinet; and then remove the GD-ROM drive from the ASSY MAIN BD as follows:

- ① Following the above described actions ① to ⑦ (to remove the NAOMI board), take out the ASSY MAIN BD from the cabinet.
- ② Remove the GD cable connector and the power cord connector from the GD-ROM drive.

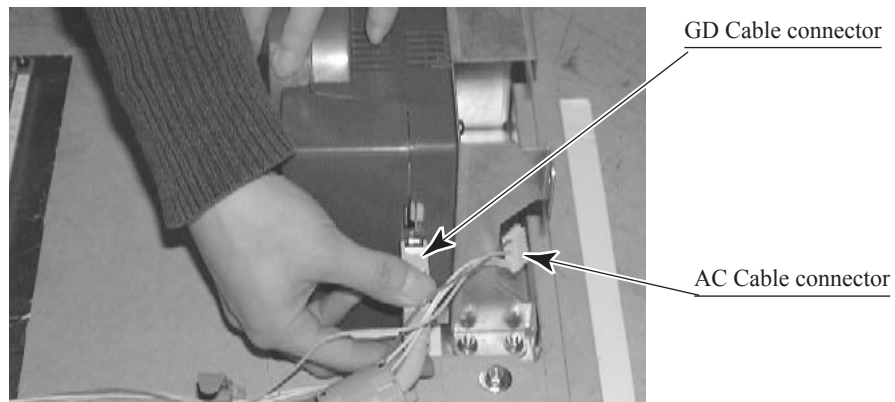

PHOTO 16. 1 e

- ③ Remove the 4 flange nuts, and thereby remove the GD-ROM drive from the ASSY MAIN BD.

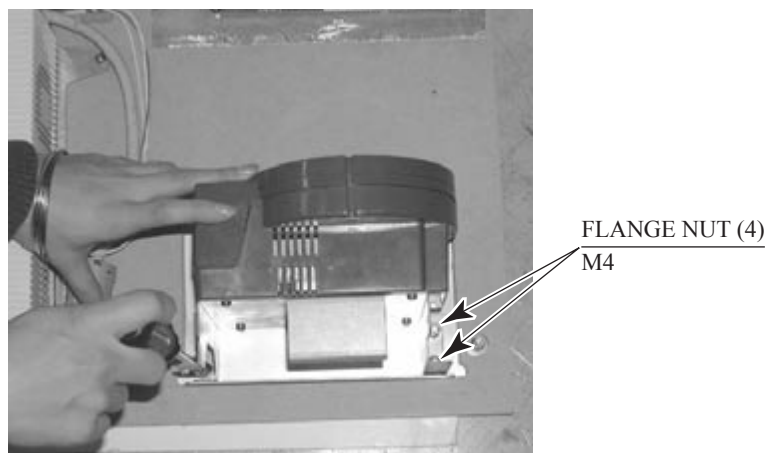
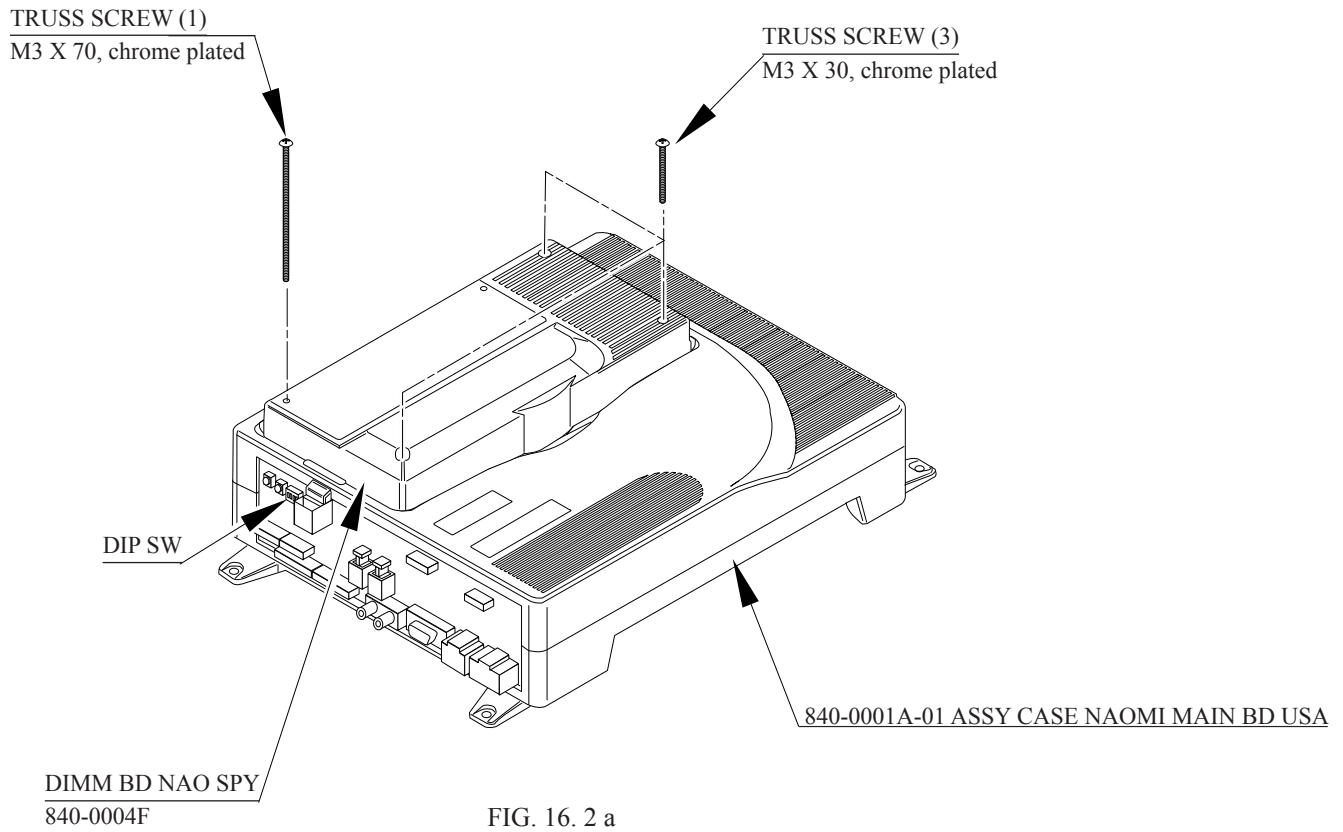

PHOTO 16. 1 f

16 - 2 COMPOSITION OF GAME BOARD

ASSY CASE NAO GD SPY USA (840-0089D-01) :USA



DIP SW SETTING

In this product, set the DIP SW to OFF.

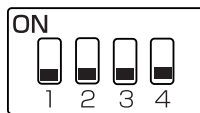
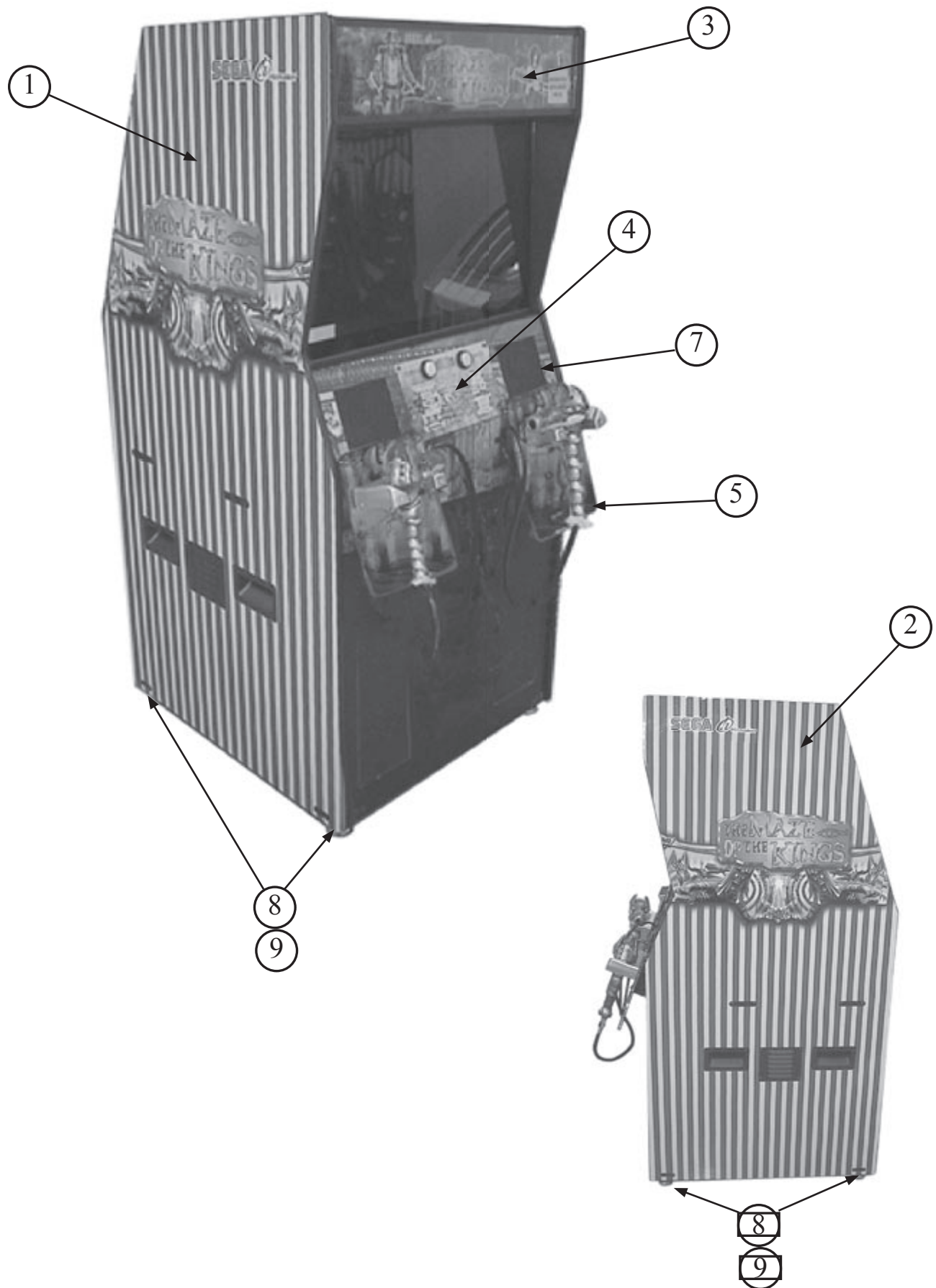

FIG. 16. 2 b

# 17. DESIGN RELATED PARTS

(D 1/2)

For the Warning Display stickers, refer to Section 1.



## 17. DESIGN RELATED PARTS

(D 2/2)

ITEM NO.	PART NO.	DESCRIPTION
1	999-1446	DECAL LEFT SIDE CABINET
2	999-1447	DECAL RIGHT SIDE CABINET
3	999-1443	MARQUEE
4		ASSY CONTROL PANEL
5	MAZ-2100	CONTROL UNIT (WAND)
6	999-1445	POP ART (NOT PICTURED)
7	999-1444	CONTROL PANEL OVERLAY
8	999-0167	LEG LEVELERS
9	999-0169	CASTERS

# 18. PARTS LIST

TOP ASSY SPY U/R

(D-1/2)

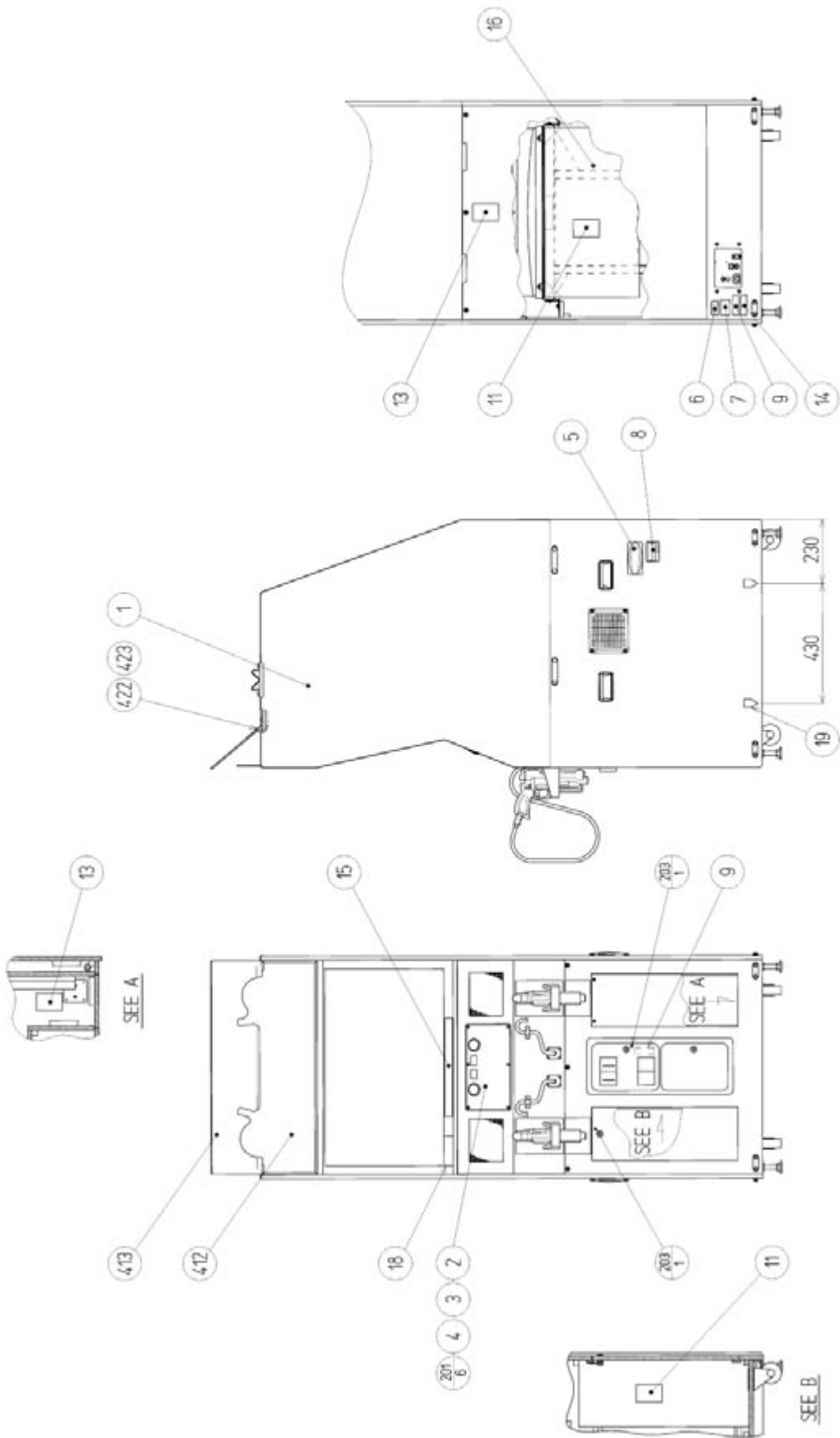

\* Drawings differ from actual game.

ITEM NO.	PART NO.	DESCRIPTION	NOTE
1	SPY-10001	ASSY CABINET U/R	
2		ASSY SW PANEL	
4	421-7907-~	DENOMI SH~	
10	421-8479-01	STICKER INSTR SUNLIGHT ENG	
11	440-DS0013XEG	STICKER D MONITOR ENG	
12	SGM-4323	POLY COVER 900 X 1300 X 1800	
13	440-WS0002XEG	STICKER W POWER OFF ENG	
15			
16	PRC-1045	COVER	
18	440-CS0186-EG	STICKER C EPILEPSY 40 ENG	
19	421-8885	STICKER CAUTION FORK	
201	000-T00412-0B	M SCR TH BLK M4 X 12	
203	008-T00412-0B	TMP PRF SCR TH BLK M4 X 12	
401	601-6604-70	CARTON BOX 70	
402	SGM-2675	POLYETHYLENE BAG, 240 X 370	
403	420-6602-01	OWNERS MANUAL SPY UR ENG	
405	9301A	KEY MASTER FOR 220-5575	
406	SGM-4111	KEY BAG (SGB-1035X)	
407	509-5080	SW MICRO TYPE	
408	390-5160	LAMP WG B TYPE 6V 3W (C2R)	
409	600-6664-02	WIRE HARN EARTH W/LUG M6 NOT USED	TAIWAN OTHERS
410	600-6729	AC CABLE CONNECT TYPE 15A	TAIWAN
	600-6618	AC CABLE CONNECT TYPE FOR EXP	OTHERS
	600-6619	AC CABLE CONNECT TYPE FOR UK	HONG KONG
414	090-0174	GLASS CLEANER NAC S-100	
415	280-5009-01	CORD CLAMP 21	
416	105-5435	GD DRIVE BRKT STD	
417	012-P00408	TAP SCR #2 PH 4 X 8	
418	050-F00400	FLG NUT M4	
419	540-0006-01	WRENCH M4 TMP SCR	
420	420-6620-01	SERVICE MANUAL NAOMI GD ENG	
421	610-0625-0001	GD SOFT SPY	
422	SPY-0005	PLATE HOLDER	
423	011-T03512	TAP SCR TH 3.5 X 12	
/	105-5356	SHIPPING BRKT	
/	421-8740	CAUTION INSTR COP U/R	
/	421-6690-05	STICKER 240V	AC 240V AREA
/	421-6690-03	STICKER 220V	AC 220V AREA
/	421-6690-06	STICKER 110V	AC 110V AREA

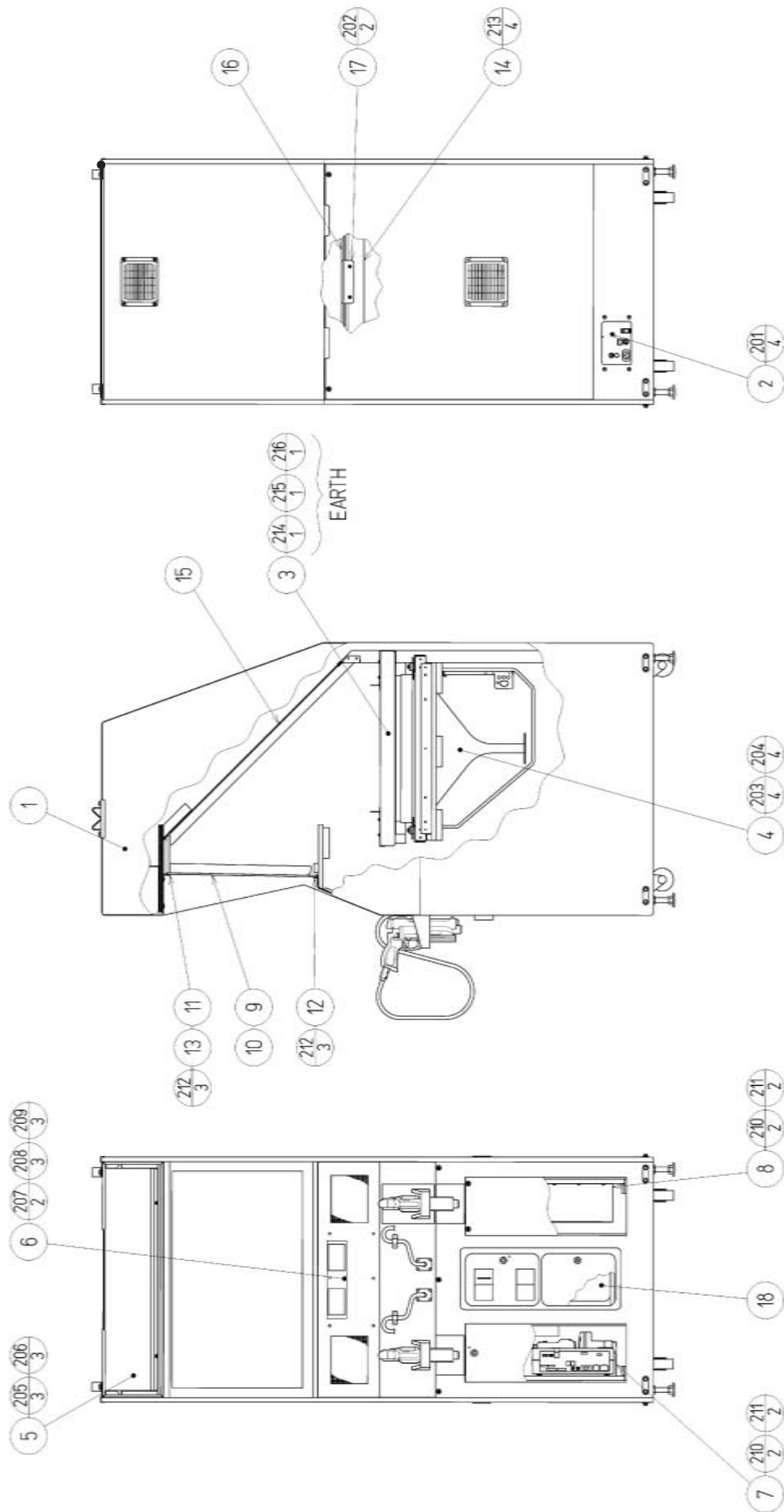

\* Drawings differ from actual game.



ASSY CABINET (SPY-10001)

(D-2/2)

ITEM NO.	PART NO.	DESCRIPTION
1	SPY-1500	ASSY SUB-CABI U/R
2		AC UNIT
3	SPY-1550	ASSY SENSOR
4		ASSY MONITOR
5	HOD-3500	ASSY BILLBOARD
6		ASSY CTRL PNL
7		ASSY MAIN BD
8		ASSY ELEC BD
9	JPT-1510	FRONT GLASS
10	AIN-1032	RUBBER PACKING
11	AIN-1033	GLASS HOLDER UPPER
12	JPT-1509	GLASS HOLDER LOWER
13	AIN-1035	CUSHION
14	AIN-1044	MIRROR BRKT
15	AIN-1038	MIRROR
16	AIN-1039	MIRROR SASH
17	AIN-1040	MIRROR HOLDER
18	253-5366	CASH BOX
201	000-T00520-0B	M SCR TH BLK M5 X 20
202	050-F00400	FLG NUT M4
203	030-000616-S	HEX BLT W/S M6 X 16
204	060-F00600	FLT WSHR M6
205	000-T00420-0B	M SCR TH BLK M4 X 20
206	068-441616-0B	FLT WSHR BLK 4.4-16 X 1.6
207	000-F00416	M SCR FH M4 X 16
208	000-T00525-0B	M SCR TH BLK M5 X 25
209	069-000017-0B	FLT WSHR BLK 5.5-16 X 1.6
210	032-000430	WING BLT M4 X 30
211	068-441616	FLT WSHR 4.4-16 X 1.6
212	000-T00516-0B	M SCR TH BLK M5 X 16
213	000-P00412-W	M SCR PH W/FS M4 X 12
214	050-H00400	HEX NUT M4
215	060-S00400	SPR WSHR M4
216	060-F00400	FLT WSHR M4

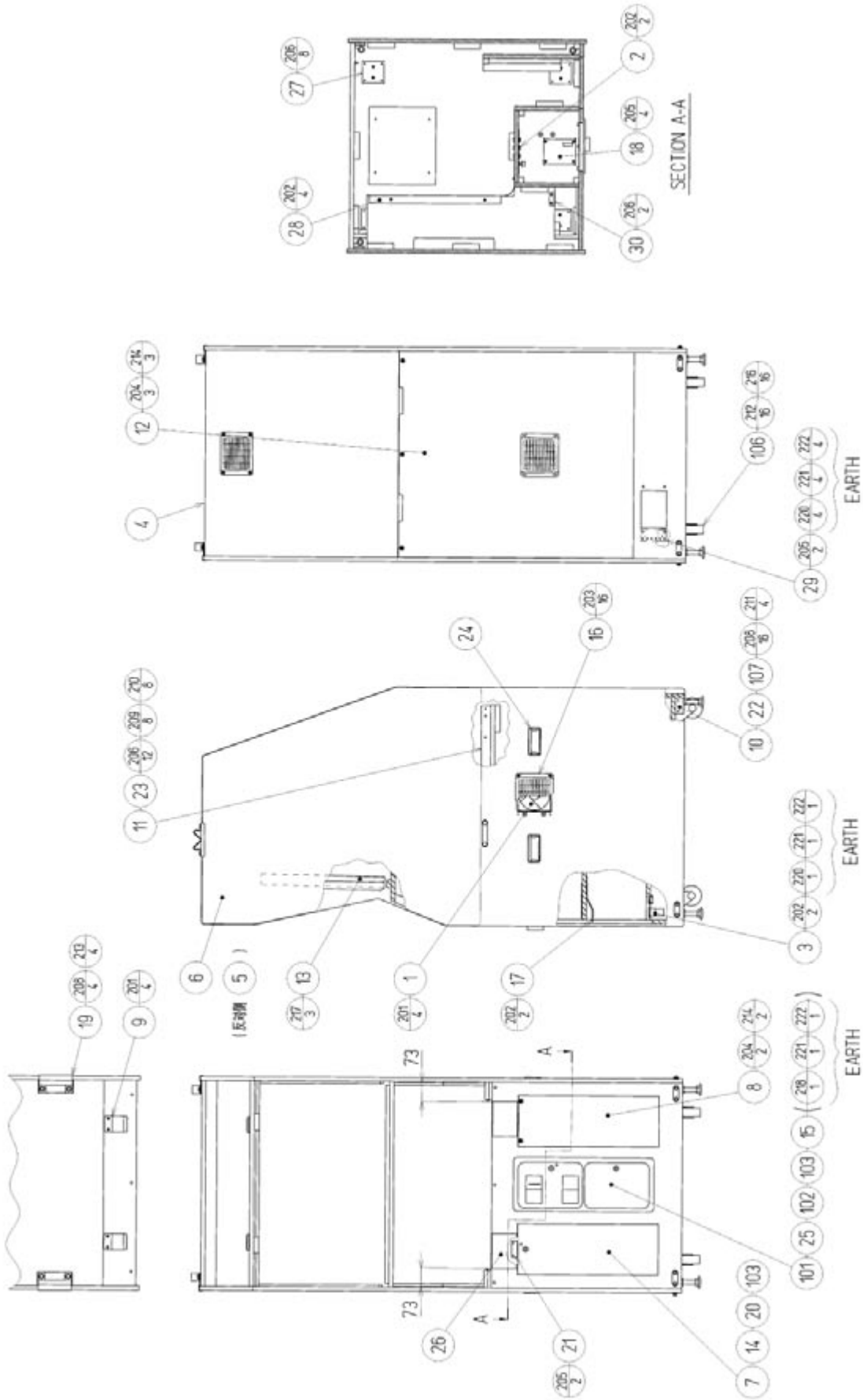

\* Drawings differ from actual game.

ITEM NO.	PART NO.	DESCRIPTION
1		FAN UNIT
2		SW UNIT
3	610-0549-01	METER UNIT SINGLE
4	SPY-1501	WOODEN CABINET U/R
5	SPY-1502	STICKER SIDE L SPY U/R
6	SPY-1503	STICKER SIDE R SPY U/R
7	SPY-1504	FRONT DOOR L
8	SPY-1505	FRONT DOOR R
9	JPT-1507	HOOK BRKT
10	ARC-1006	LEG BRACKET
11	AIN-1008	MONITOR SUPPORT BRKT
12	COP-1503	BACK DOOR
13	COP-1506	WIRE COVER
14	DP-1148X	LKG TNG
15	DP-1167	TNG LKG
16	253-5460-01	AIR VENT BLACK
17	105-5169	LOCK BRACKET W
18	105-5171	CHUTE PLATE SINGLE
19	105-5258-01	SHIPPING HOOK BRKT RED
20	117-0062	PLATE LOCK RETAINER
21	117-5098	TNG RETAINER PLATE
22	117-5233	PLATE LEG BRACKET BLACK
23	117-5284	PLATE 6-80 BLACK
24	253-5396-91	CABINET HANDLE
25	421-7501-02	STICKER 6.3V 0.15A
26	JPT-1508	PROTECT SHEET B
27	SCR-1008	NUT PLATE FOR CASTER
28	SPY-1506	COVER SIDE
29	SPY-1507	EARTH PLATE
30	SPY-1508	CLAMP BASE
101	220-5482-91-~	ASSY C.C ~
	220-5237-92-~	ASSY C.C ~
102	220-5574	CAM LOCK W/KEYS
103	220-5575	CAM LOCK MASTER W/O KEY
104	280-5275-SR10	CORD CLAMP SR10
105	310-5029-F20	SUMITUBE F F 20MM
106	601-9377	CASTER FAI=75
	601-6224	CASTER 75
107	601-5699X	LEG ADJUSTER BOLT M16 X 75
108	280-5009-01	CORD CLAMP 21
109	280-5207	HARNESS LUG CC-1005
110	280-5169	CORD CLAMP TL-20S

ITEM NO.	PART NO.	DESCRIPTION	NOTE
201	000-P00416-W	M SCR PH W/FS M4 X 16	
202	000-P00420-W	M SCR PH W/FS M4 X 20	
203	000-T00420-0B	M SCR TH BLK M4 X 20	
204	008-T00430-0B	TMP PRF SCR TH BLK M4 X 30	
205	011-T00312	TAP SCR TH 3 X 12	
206	011-T03512	TAP SCR TH 3.5 X 12	
207	030-000630-SB	HEX BLT BLK W/S M6 X 30	
208	030-000830-SB	HEX BLT W/S BLK M8 X 30	
209	031-000630-0B	CRG BLT BLK M6 X 30	
210	050-F00600	FLG NUT M6	
211	050-H01600	HEX NUT M16	
212	060-F00600	FLT WSHR M6	
213	060-F00800-0B	FLT WSHR BLK M8	
214	068-441616-0B	FLT WSHR BLK 4.4-16 X 1.6	
215	011-F00310	TAP SCR FH 3 X 10	
216	030-000625-S	HEX BLT W/S M6 X 25	
217	011-P00316-0B	TAP SCR #1 PH BLK 3 X 16	
218	000-P00408	M SCR PH M4 X 8	
220	050-H00400	HEX NUT M4	
221	060-S00400	SPR WSHR M4	
222	060-F00400	FLT WSHR M4	
301	SPY-6001	ASSY WIRE CABI DC	
302	SPY-6002	ASSY WIRE CABI AC	
303	600-6455-02	WIRE HARN C.C DOOR SINGLE	
305	SPY-61011	WH LED EXT	
306	600-6972-0120	WIRE HARN EARTH ID5 0120MM	
/	000-P00430-W	M SCR PH W/FS M4 X 30	

SW UNIT

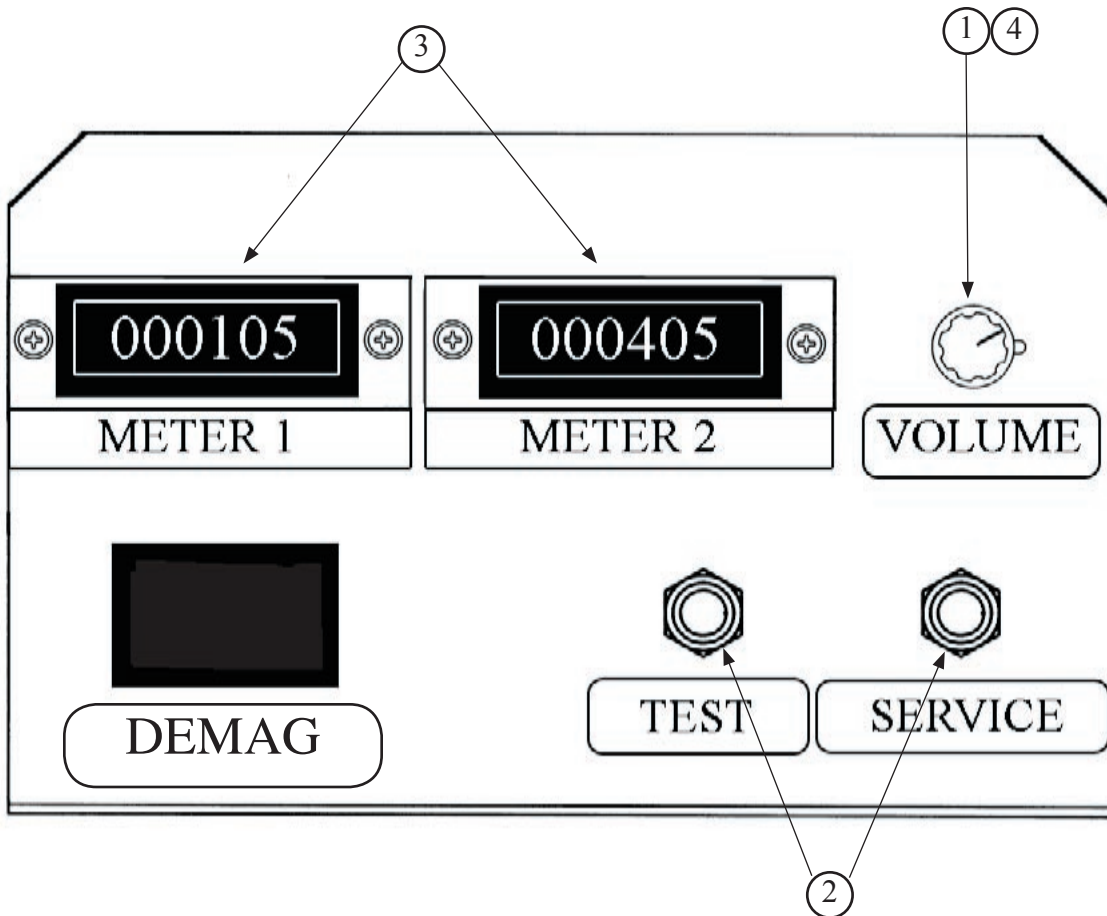

ITEM NO.	PART NO.	DESCRIPTION
1	LOCAL PURCHASE	VOLUME KNOB 1/4" - MOUSER#450-+2023
2	LOCAL PURCHASE	SWITCH TEST/SVC .5 AMP - MOUSER#104-0015
3	999-1050	COIN METER - IMPERIAL
4	999-1222	VOL CONT B-5K OHM (CONNECTED TO VOLUME KNOB)

AC UNIT

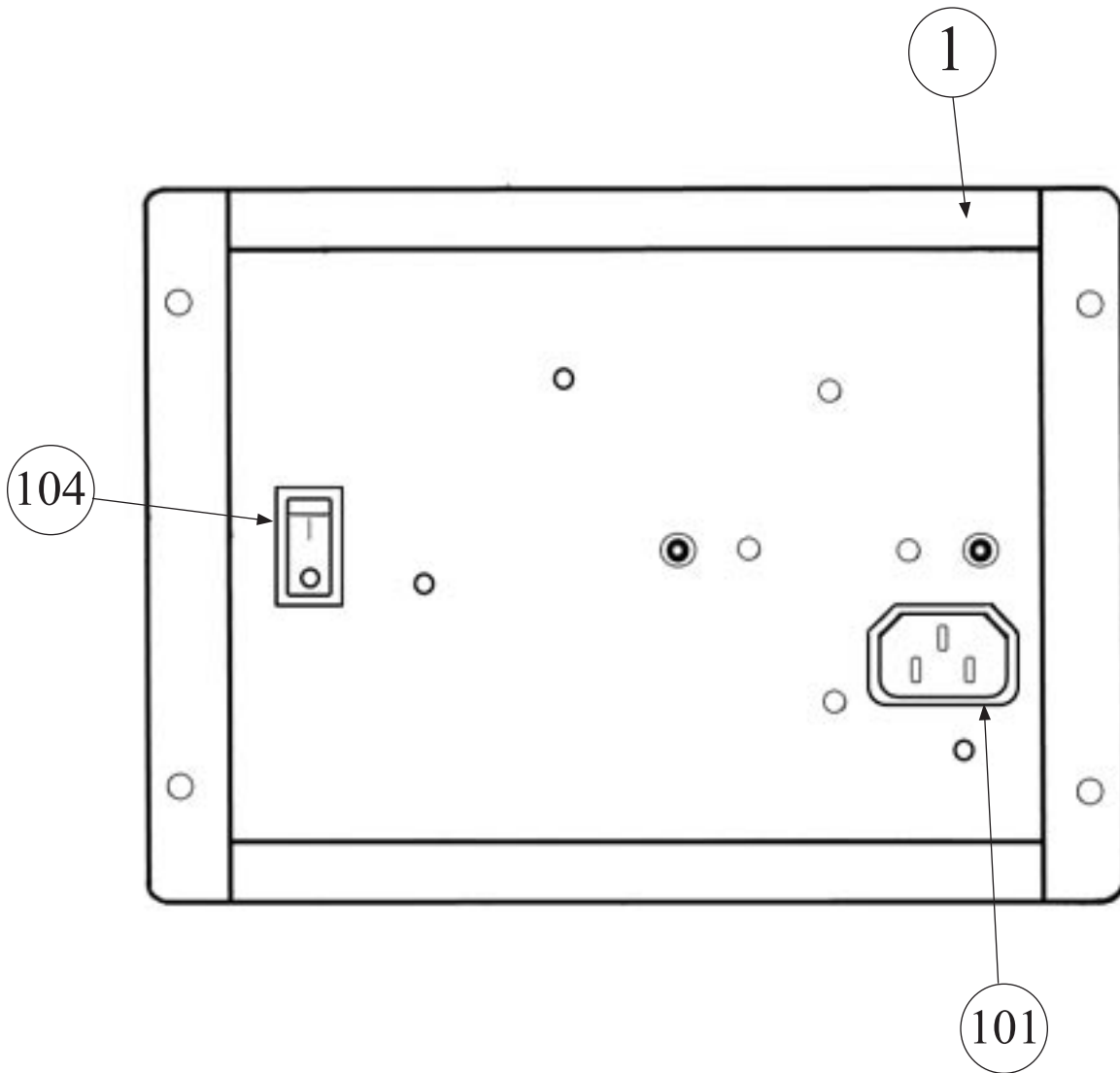

ITEM NO.	PART NO.	DESCRIPTION
1	999-1043	AC BRKT
NOT SHOWN	DYN-0402	NOISE FILTER BASE
NOT SHOWN	421-8202	STICKER EARTH MARK
101	999-1044	AC INLET PANEL TYPE
104	999-0676	SW ROCKER J8 V-B

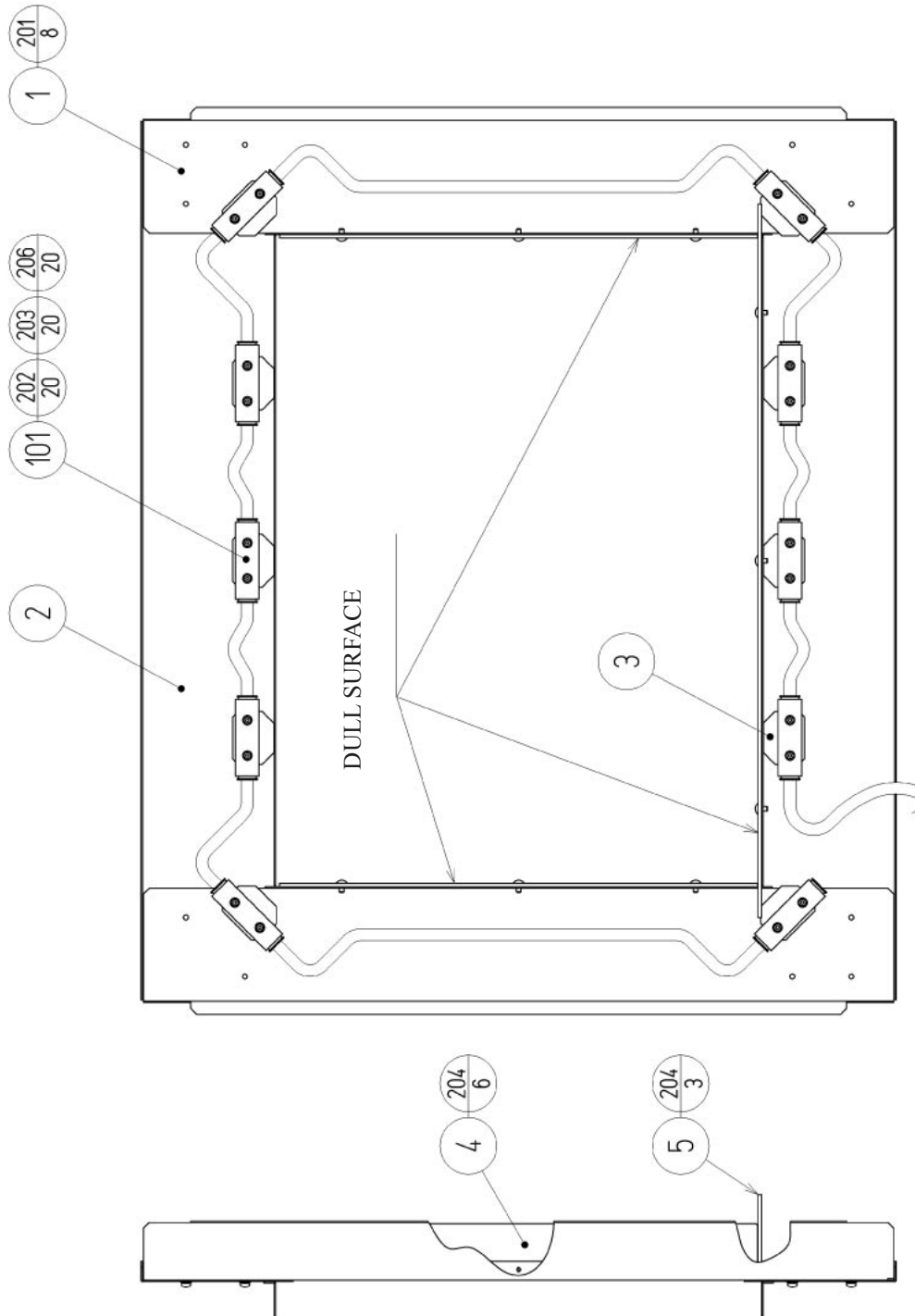

## ASSY SENSOR (SPY-1550)

(D-2/2)

ITEM NO.	PART NO.	DESCRIPTION
1	HOD-1551	SENSOR BRKT SIDE
2	HOD-1552	SENSOR BRKT
3	JPT-1082	IR COVER
4	SPY-1551	MONITOR COVER SIDE
5	SPY-1552	MONITOR COVER
101	838-13145-02	LED BD GUN SENSE HOD
102	280-5008	CORD CLAMP 15
201	000-P00408-WB	M SCR PH W/FS BLK M4 X 8
202	050-U00300	U NUT M3
203	068-330808-PN	FLT WSHR PLASTIC 3.3-8 X 0.8
204	069-000026	FLT WSHR 3.2-11 X 0.5
205	000-T00408-0B	M SCR TH BLK M4 X 8
301	SPY-61012	WH MASK INTO
302	SPY-61013	WH MASK SHORT
303	SPY-61014	WH MASK LONG



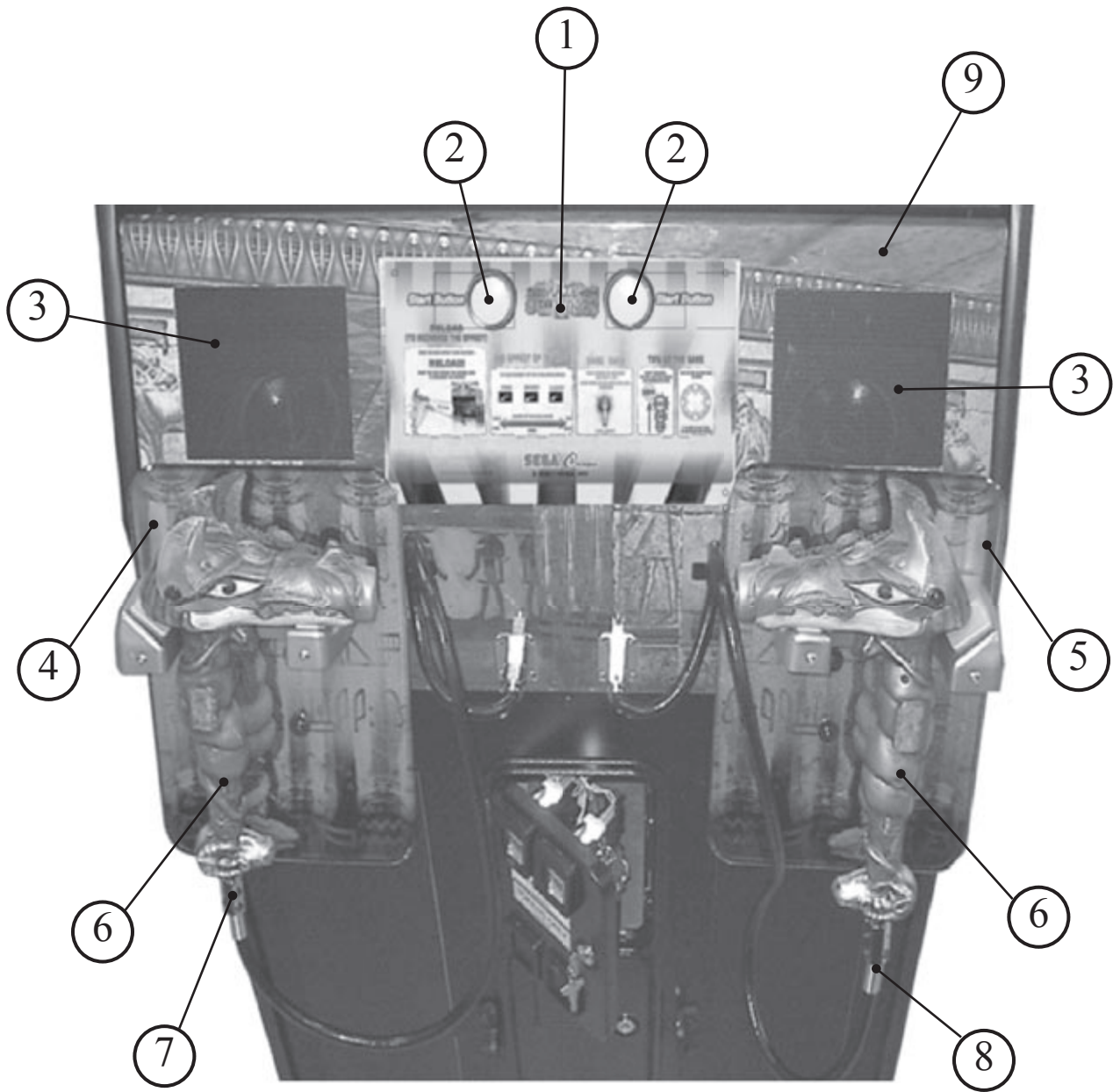

ASSY CONTROL PANEL STD

(D-2/2)

ITEM NO.	PART NO.	DESCRIPTION
1	999-1448	INSTRUCTION PLATE
2	509-5712-01	SW PB W/L 6V YELLOW
3	999-1442	SPEAKERS
4	999-1454	WAND HOLDER PLATE LEFT
5	999-1453	WAND HOLDER PLATE RIGHT
6	MAZ-2100	CONTROL UNIT (WAND)
7	999-1451	HARNESS WAND (PLAYER 1)
8	999-1452	HARNESS WAND (PLAYER 2)
9	999-1444	CONTROL PANEL OVERLAY
NOT PICTURED	999-1449	STICKER GUN BOARD L ENG
NOT PICTURED	999-1450	STICKER GUN BOARD R ENG

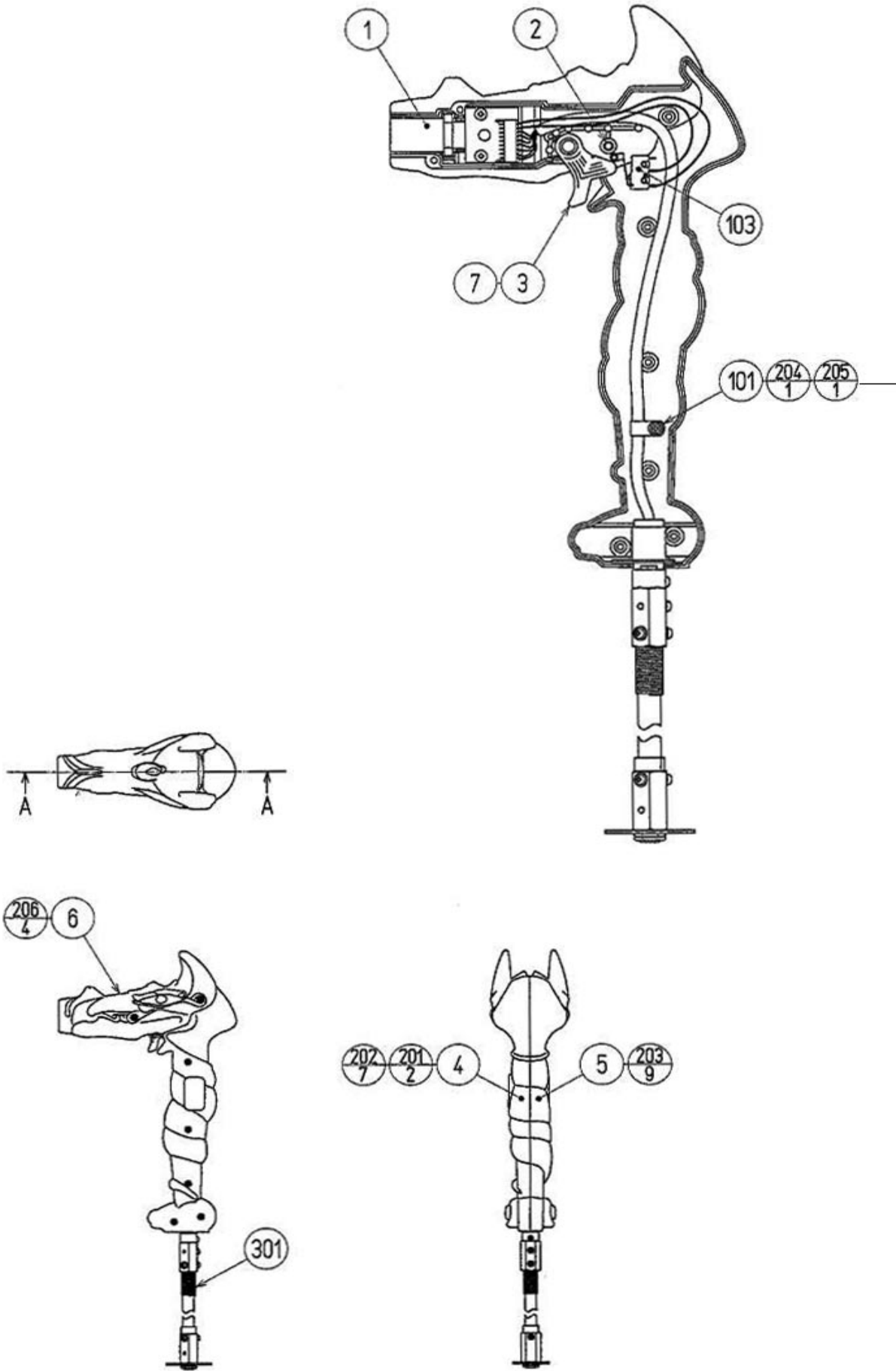

## CONTROL UNIT STD WAND (MAZ-2100)

(D-2/2)

ITEM NO.	PART NO.	DESCRIPTION
1	JPT-2030	SENSOR UNIT
2	COP-2005	STOPPER PIN
3	125-5124	TORSION SPRING
4	MAZ-2101	COVER BODY L
5	MAZ-2102	COVER BODY R
6	MAZ-2103	COVER HEAD
7	MAZ-2104	TRIGGER
101	280-5124-03	NYLON CLAMP NKO3
102	310-5029-D20	SUMITUBE F D 20MM
103	509-5080	SW MICRO TYPE (SS-5GL2)
104	601-0460	PLASTIC TIE BELT 100 M/M
201	FAS-000080	M SCR PH W/SMALL FS BLK M3X20
202	FAS-000081	M SCR PH W/SMALL FS BLK M3X28
203	FAS-500006	CAP NUT TYPE 3 BLK M3
204	012-P00308	TAP SCR #2 PH 3X8
205	060-F00300	FLT WSHR M3
206	FAS-110013	TAP SCR BI H #1 BLK 3X10

# SENSOR UNIT (JPT-2030)

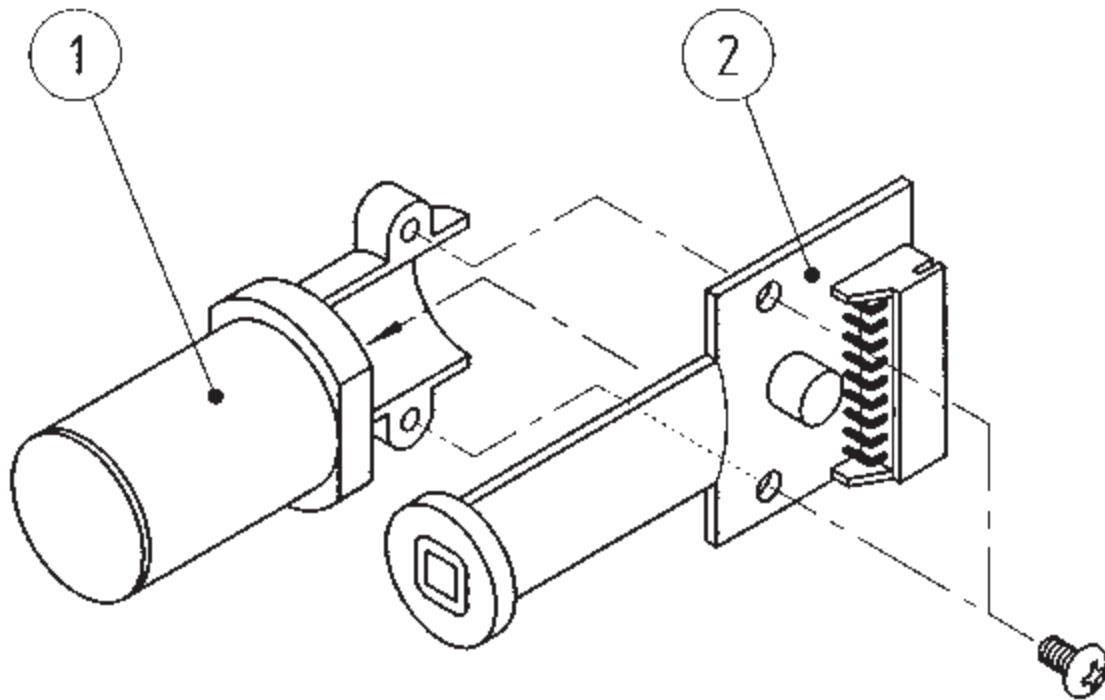

ITEM NO.	PART NO.	DESCRIPTION
1	JPT-2031	SENSOR HOLDER
2	838-13144-91	SENSOR BD GUN SENSE (NOT SOLD SEPARATELY)

# ASSY SW PANEL

1

101

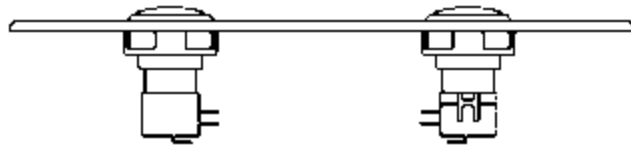
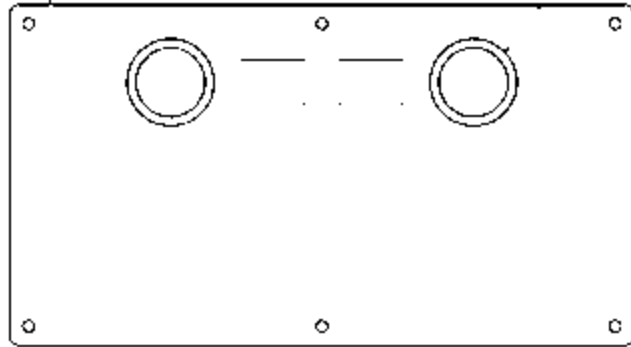

ITEM NO.	PART NO.	DESCRIPTION
1	999-1448	INSTRUCTION PLATE STD
101	509-5712-01	SW PB W/L 6V YELLOW
301	600-6457-10	WIRE HARN START
302	600-6457-36	WIRE HARN START EX

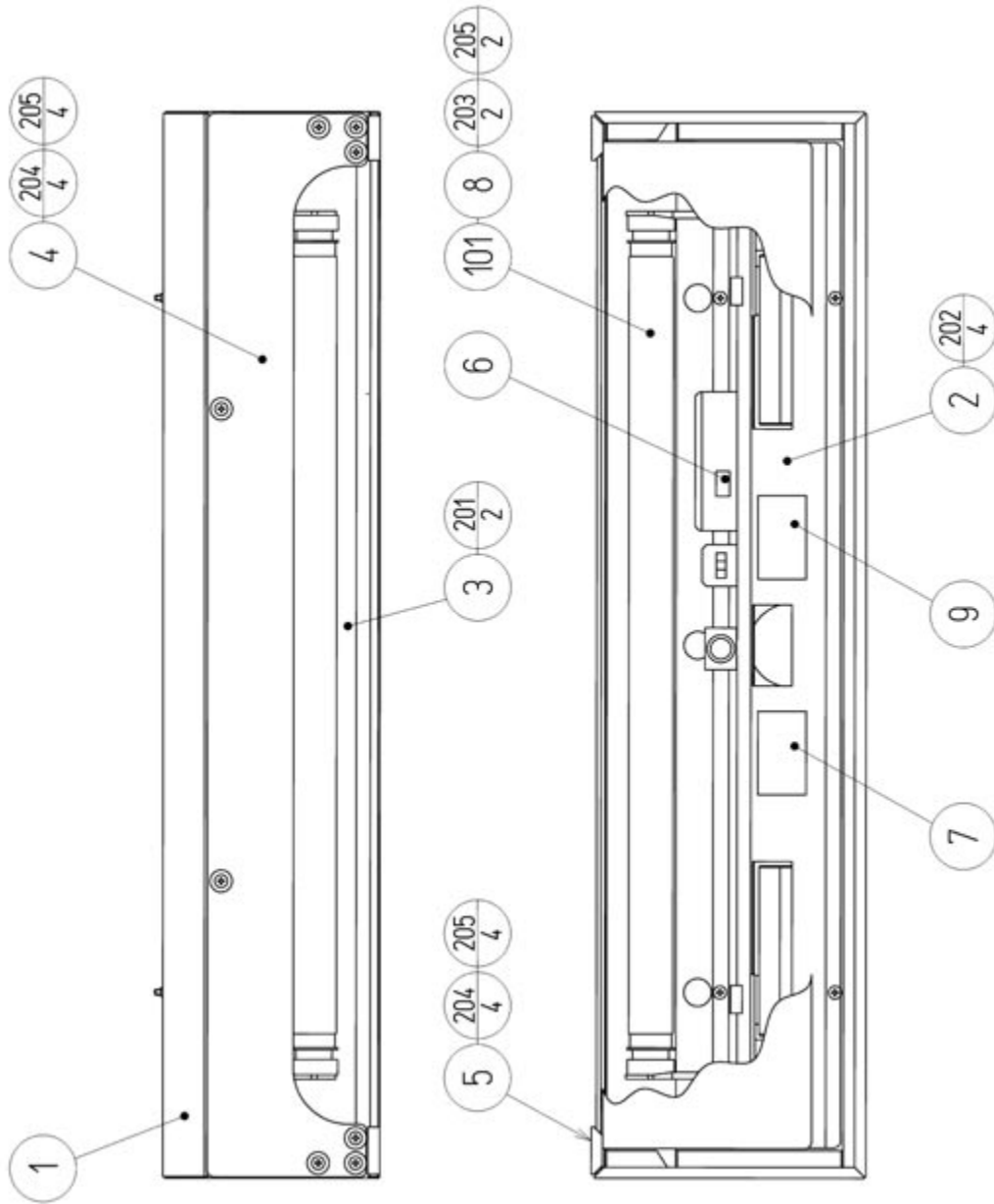

10

ASSY BILLBOARD (HOD-3500)

(D-2/2)

ITEM NO.	PART NO.	DESCRIPTION
1	HOD-3501	BILLBOARD CASE
2	JPT-3502	REFLECTOR
3	JPT-3503	LAMP COVER A
4	HOD-3504	LAMP COVER B
5	HOD-3505X	BILLBOARD UPPER SUSH
6		
7		
8		
9		
10	999-1443	MARQUEE
101	Local Purchase	ASSY FL20W 24" SD W/CONN HIGH T
	Local Purchase	ASSY FL20W 24" W/CONN HIGH L
	Local Purchase	ASSY FL20W 24" W/CONN HIGH S



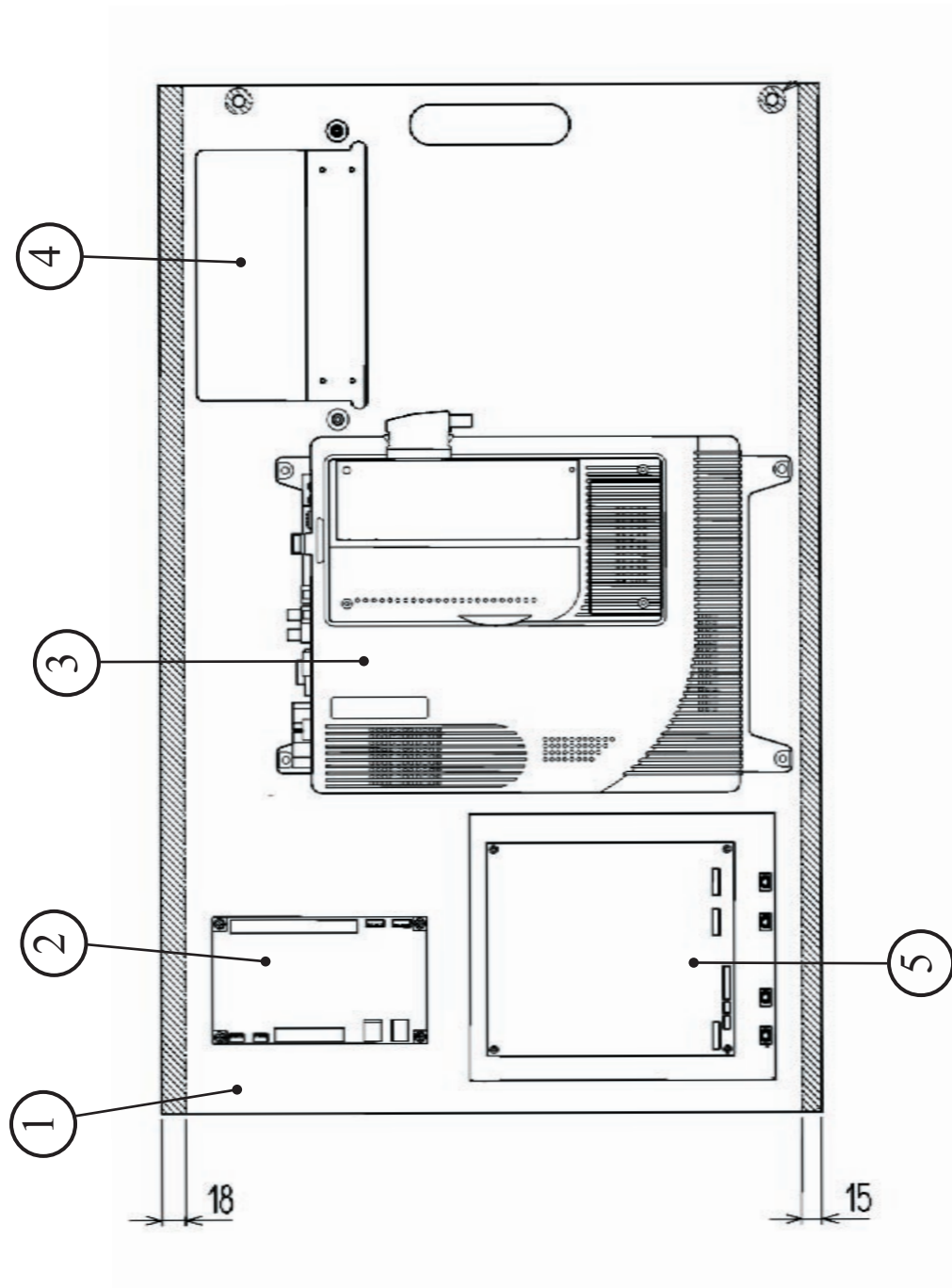

ASSY MAIN BD

(D-2/2)

ITEM NO.	PART NO.	DESCRIPTION	NOTE
1	SPY-4201	MAIN BASE	
2	838-13683-02	I/O BOARD JVS TO JAMMA	
3	840-0089D-01	ASSY CASE NAO RTOS DIMM BD	USA
4	SPY-4202	GD HOLDER	
5	400-5397-01	POWER SUPPLY	

# ASSY ELEC BD

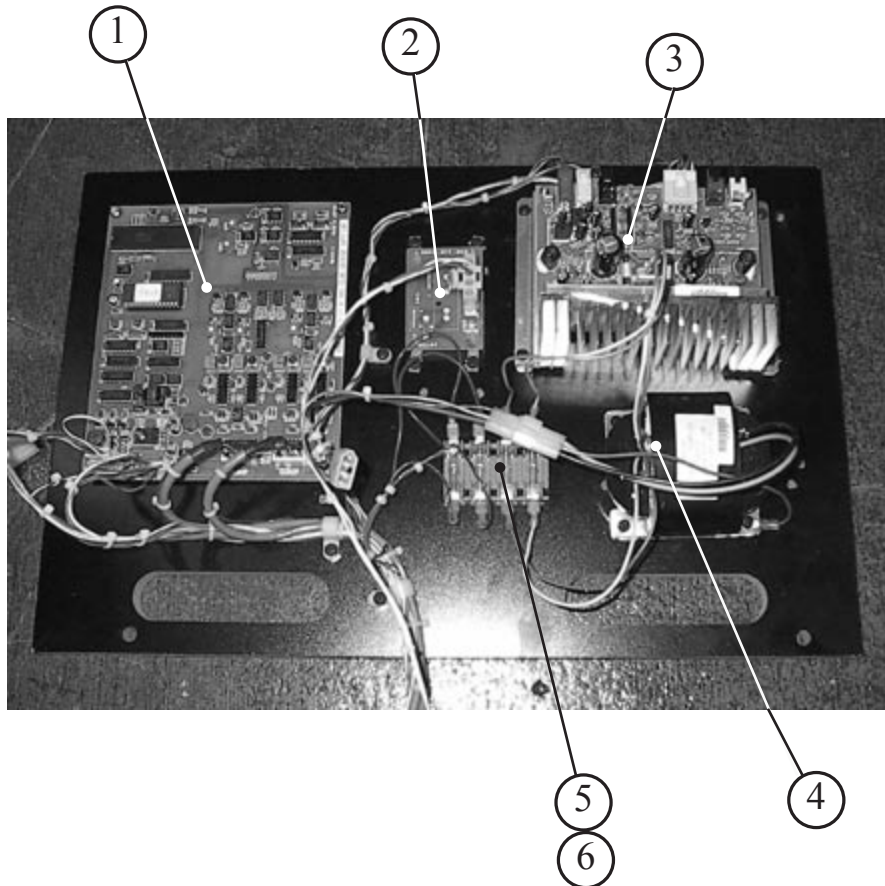

ITEM NO.	PART NO.	DESCRIPTION
1	838-13143-09	IC BD GUN SENSE SPY UR
2	839-0979	CONDENSER BD
3	838-13616	AUDIO POWER AMP WS KIT
4	560-5407-UL	TRANSFORMER
5	LOCAL PURCHASE	FUSE HOLDER
6	LOCAL PURCHASE	FUSES 3AMP

# 19. WIRE COLOR CODE TABLE

THE WIRE COLOR CODE is as follow:

- A PINK
- B SKY BLUE
- C BROWN
- D PURPLE
- E LIGHT GREEN

Wires other than those of any of the above 5 single colors will be displayed by 2 alphanumeric characters.

- 1 RED
- 2 BLUE
- 3 YELLOW
- 4 GREEN
- 5 WHITE
- 7 ORANGE
- 8 BLACK
- 9 GRAY

If the right-hand side numeral of the code is 0, then the wire will be of a single color shown by the left-hand side numeral (see the above).

Note 1: If the right-hand side alphanumeric is not 0, that particular wire has a spiral color code. The left-hand side character shows the base color and the right-hand side one, the spiral color.

<Example> 51 ..... WHITE / RED

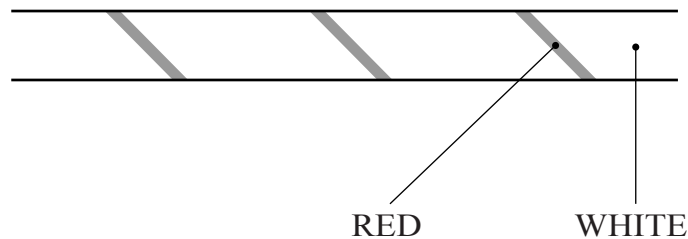

Note 2: The character following the wire color code indicates the size of the wire.

- U: AWG16
- K: AWG18
- L: AWG20
- None: AWG22

## **Warranty**

Your new Sega Product is covered for a period of 90 days from the date of shipment. This certifies that the Printed Circuit Boards, Power Supplies and Monitor are to be free of defects in workmanship or materials under normal operating conditions. This also certifies that all Interactive Control Assemblies are to be free from defects in workmanship and materials under normal operating conditions. No other product in this machine is hereby covered.

Sellers sole liability in the event a warranted part described above fails shall be, at its option, to replace or repair the defective part during the warranty period. For Warranty claims, contact your Sega Distributor.

Should the Seller determine, by inspection that the product was caused by Accident, Misuse, Neglect, Alteration, Improper Repair, Installation or Testing, the warranty offered will be null and void.

Under no circumstances is the Seller responsible for any loss of profits, loss of use, or other damages.

This shall be the exclusive written Warranty of the original purchaser expressed in lieu of all other warranties expressed or implied. Under no circumstance shall it extend beyond the period of time listed above.



**SEGA ENTERPRISES, INC. (USA)**

45133 Industrial Drive  
Fremont, CA 94538  
**(415) 701-6580** phone  
**(415) 701-6594** fax